

## COMPARATIVE STUDY OF EMISSION CHARACTERISTICS FOR A MODIFIED CAM IN CARBURETTOR AND MPFI ENGINE

Manjunath Gowda M. R\*<sup>1</sup>, Harish Kumar R<sup>2</sup> and N. S. Venkatesh Guptha<sup>3</sup>

<sup>1</sup>Research Scholar, Dept. of Mechanical Engg, VTU-RRC, Belgaum, Karnataka, India.

<sup>2</sup>Professor of Mechanical Engineering, S.S.I.T, Tumkur, Karnataka, India.

<sup>3</sup>Associate Prof of Mechanical Engineering S.I.T, Tumkur, Karnataka, India.

Article Received on 24/02/2017

Article Revised on 17/03/2017

Article Accepted on 06/04/2017

### \*Corresponding Author

**Manjunath Gowda M. R.**

Research Scholar, Dept. of  
Mechanical Engg, VTU-  
RRC, Belgaum, Karnataka,  
India.

### ABSTRACT

An internal combustion engine (ICE) is a heat engine where the combustion of a fuel occurs with an oxidizer (usually air) in a combustion chamber that is an integral part of the working fluid flow circuit. In an internal combustion engine the expansion of the high-temperature and high-pressure gases produced by combustion apply

direct force to some component of the engine. The comparative study of Emission Characteristics has been made at different profiles of modified Cam for Carburettor and MPFI Engine. An Emission qualities have been learned at 3 unique profiles of cam for carburettor and MPFI Engine and a significant reduction in discharges have been recorded in MPFI Engine is contrasted with carburettor Engine.

**KEYWORDS:** MPFI Engine, Carburettor, Variable Valve timing, TRI-LOBED-CAM, Valve dynamics.

### INTRODUCTION

In conventional engine design, the camshaft uses a fixed or variable cam profile to achieve a reasonable compromise between idle speed stability, fuel economy, and torque performance. Significant improvements in engine performance can be achieved through individual control of the valve timing.

So In internal combustion engines, Variable valve timing (VVT), also known as Variable valve actuation (VVA), is a generalized term used to describe any mechanism or method that can alter the shape or timing of a valve lift event within an internal combustion engine. VVT allows the lift, duration or timing (in various combinations) of the intake and/or exhaust valves to be changed while the engine is in operation.

The automotive industry has been under continued pressure to improve the fuel efficiency owing to stringent pollution norms, global warming and rising petroleum prices. The largest part of most combustion gas is nitrogen (N<sub>2</sub>), water vapor (H<sub>2</sub>O) and carbon dioxide (CO<sub>2</sub>) these are not toxic. A relatively small part of combustion gas is undesirable noxious or toxic substances, such as carbon monoxide (CO) from incomplete combustion, hydrocarbons (properly indicated as C<sub>x</sub>H<sub>y</sub>, but typically shown simply as "HC" on emissions-test slips) from unburnt fuel, nitrogen oxides (NO<sub>x</sub>) from excessive combustion temperatures, and particulate matter (mostly soot).

Exhaust gas or flue gas is emitted as a result of the combustion of fuels such as natural gas, gasoline, petrol, biodiesel blends, fuel, fuel or coal. According to the type of engine, it is discharged into the atmosphere through an exhaust pipe, flue gas stack or propelling nozzle.

Fuel (hydrogen, carbon, sulphur) + Air (nitrogen, oxygen) = Carbon dioxide + water vapour + oxygen + carbon monoxide + hydrocarbon + oxides of nitrogen + sulphur oxides.

Carbon monoxide (CO) - A product of incomplete combustion, concentration of the exhaust in percent of the total sample. Partially Burned Petrol, This is the petrol that has combusted, but not completely. This gas is formed in the cylinders when there is incomplete combustion and an excess of fuel. Therefore excessive CO contents are always a sign of an overly rich mixture preparation. (The CO should have become CO<sub>2</sub> but did not have the time or enough O<sub>2</sub> to become real CO<sub>2</sub> so it is exhausted as CO instead.) CO is highly poisonous odorless gas. Carbon monoxide reduces the blood's ability to carry oxygen; overexposure (carbon monoxide poisoning) may be fatal. Carbon Monoxide poisoning is a killer in high concentrations.

Hydrocarbons - A class of burned or partially burned fuel, hydrocarbons are toxins. Hydrocarbons are a major contributor to smog, which can be a major problem in urban areas. Concentration of the exhaust in parts per million (ppm). Unburned Petrol, represents the

amount of unburned fuel due to incomplete combustion exiting through the exhaust. Prolonged exposure to hydrocarbons contributes to asthma, liver disease, lung disease, and cancer.

Carbon dioxide is a greenhouse gas. Motor vehicle CO<sub>2</sub> emissions are part of the anthropogenic contribution to the growth of CO<sub>2</sub> concentrations in the atmosphere which is causing climate change. Concentration of the exhaust in percent of the total sample. = Completely Burned Petrol, represents how well the air/fuel mixture is burned in the engine (efficiency). This gas gives a direct indication of combustion efficiency. This is due to improved gas flow resulting in better combustion efficiency.

Particulate matter – Soot or smoke made up of particles in the micrometer size range, Particulate matter causes negative health effects, including but not limited to respiratory disease and cancer. An instrument exhaust gas analyzer is used to find the emissions CO, HC and CO<sub>2</sub>.

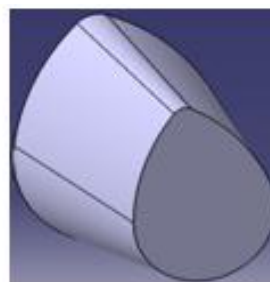
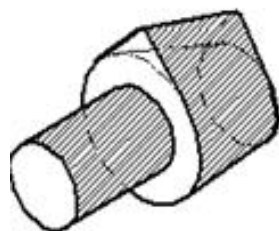
## OBJECTIVE

The proposed new design of the valve actuator mechanism is expected to overcome the inherent limitations of the fixed cam valve actuation mechanisms as well as the deficiencies of the VVT cam systems marginally.

A new “TRI-LOBED-CAM” mechanism used in conjunction with a conventional cam operating mechanism that axially shifts the camshaft through a small displacement depending on the operating conditions of the engine

The emission characteristics for carburettor and MPFI engine is studied at 3 different locations of the modified CAM where the valve movement is varied and controlled by using the modified CAM Shaft.

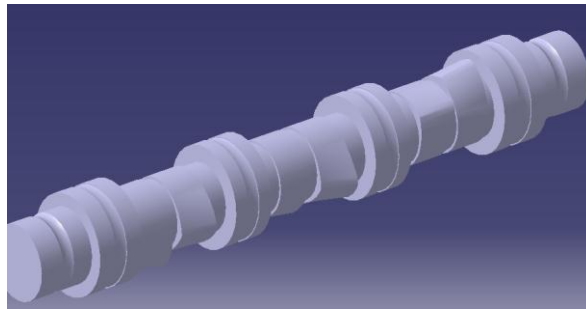
## Experimentation using Modified Cam





**Fig 1: Tri Lobed CAM.**

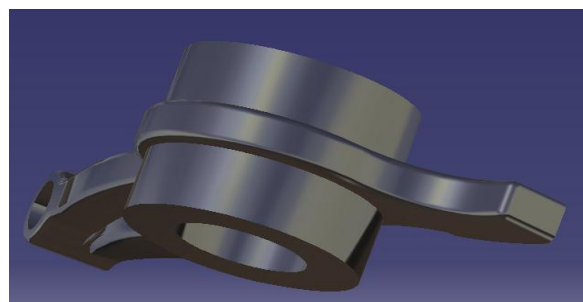
### Modified Camshaft



**Fig 2: MODIFIED Iso-metric view of CAM SHAFT.**

The changed camshaft conveys one decreased cam for every valve to be worked. The camshaft is driven by the crankshaft by method for timing gears. It comprises of round and hollow bar with various decreased flaps projecting from it, one for every valve. The profile of the altered camshaft is upgrade with falt surface to tapered(slope) shape.

### Modified Rocker



**Fig 3: MODIFIED ROCKER with Edges.**

The modified rocker arm conveys radial movement from the cam lobe into linear movement at the poppet valve to open it. One end is raised and lowered by a rotating of the camshaft that is reduced their width while the other end acts on the valve stem. The modified rocker having point contact with the respective cam and it is made of forged steel or cast iron.



Modified Cam Shaft with rocker is placed in the engine head and emission of CO, HC and CO<sub>2</sub> is noted for different profiles of CAM plotted wrt to valve movement.



Emission characteristics for MPFI Engine is studied at 3 different locations of Cam Shaft which is shown below.

### Emission characteristics at 3 different locations for 8° & 9° degree of taper turn in CAM for Carburettor engine

For 8° of Taper turn in CAM

**Table 5: Exhaust emission at Maximum, Centre and Minimum for 8° of Taper turn in CAM in carburettor engine.**

SL NO	Diameter of the CAM (mm)	Valve lift in mm	Exhaust Emission of CO	Exhaust Emission of HC	Exhaust Emission of CO <sub>2</sub>
1	35.74(Maximum)	7.319	3.640	501	11.24
2	34.62(Centre)	6.022	2.291	402	8.02
3	33.6(Minimum)	4.396	1.680	314	6.13

**Table 6: Exhaust emission at Maximum, Centre and Minimum for 8° of Taper turn in CAM in MPFI engine.**

SL NO	Diameter of the CAM (mm)	Valve lift in mm	Exhaust Emission of CO	Exhaust Emission of HC	Exhaust Emission of CO <sub>2</sub>
1	35.74(Maximum)	7.319	0.648	346	11.62
2	34.62(Centre)	6.022	0.445	90	10.84
3	33.6(Minimum)	4.396	0.280	58	10.02



### Exhaust emission at Maximum, Centre and Minimum for $8^{\circ}$ of Taper turn in CAM in MPFI engine

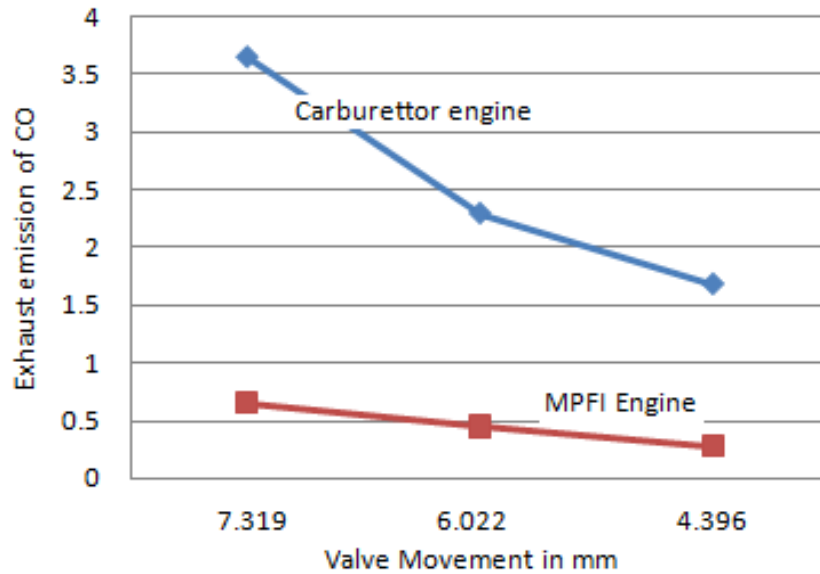


Fig 6: Valve Movement V/S Exhaust emission of CO

When the rocker is placed on the maximum, centre and minimum diameter of the Cam Shaft then the valve movement is decreased so that the exhaust emission CO is reduced.

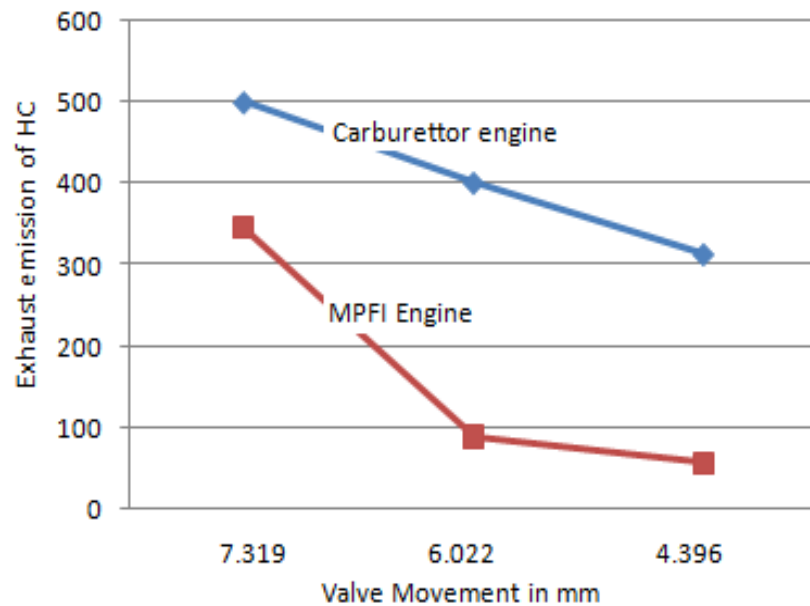
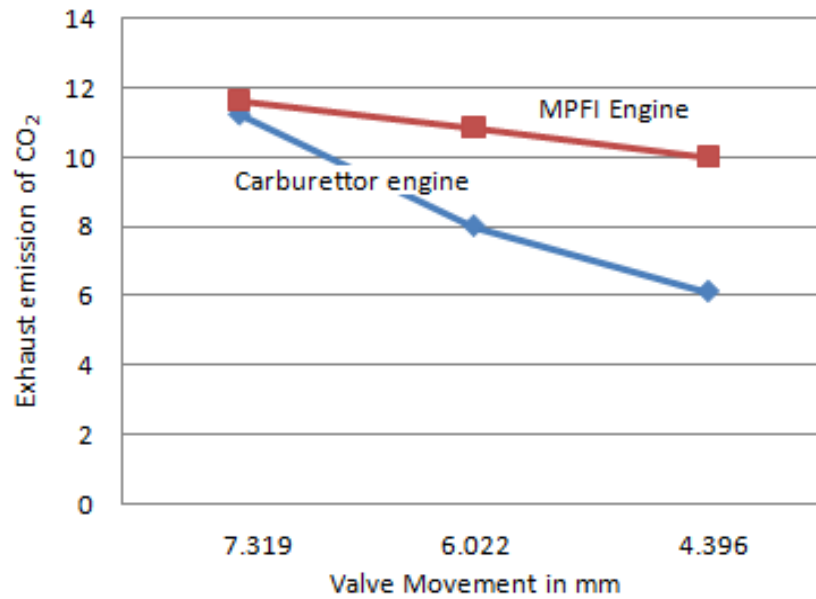


Fig 7: Valve Movement V/S Exhaust emission of HC

When the rocker is placed on the maximum, centre and minimum diameter of the Cam Shaft then the valve movement is decreased so that the exhaust emission HC is reduced.



**Fig 8: Valve Movement V/S Exhaust emission of CO<sub>2</sub>**

When the rocker is placed on the maximum, centre and minimum diameter of the Cam Shaft then the valve movement is decreased so that the exhaust emission CO<sub>2</sub> is reduced.

For 9° of Taper turn in CAM

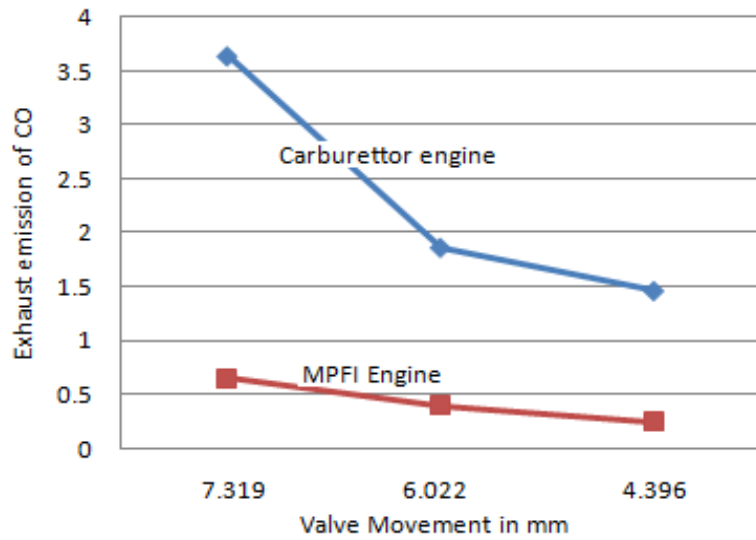
**Table 7: Exhaust emission at Maximum, Centre and Minimum for 9° of Taper turn in CAM in carburettor engine.**

SL NO	Diameter of the CAM (mm)	Valve lift in mm	Exhaust Emission of CO	Exhaust Emission of HC	Exhaust Emission of CO <sub>2</sub>
1	35.74(Maximum)	7.319	3.640	501	11.24
2	34.47(Centre)	5.925	1.863	491	7.65
3	33.45(Minimum)	3.961	1.460	103	2.77

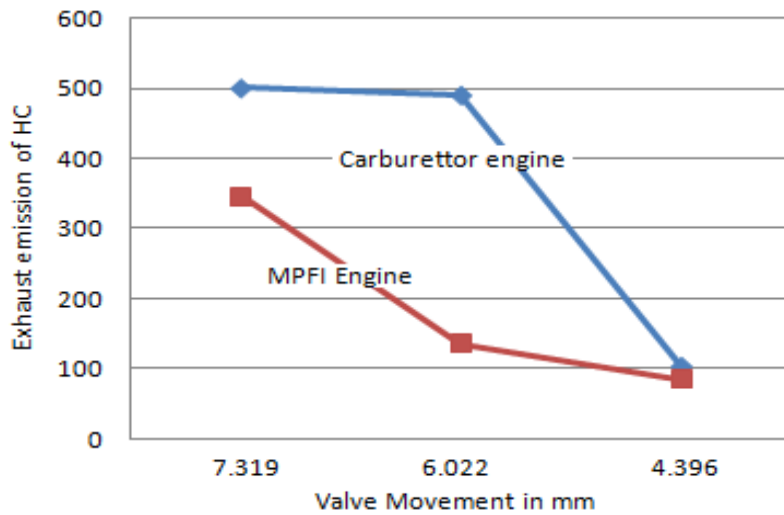
**Table 8: Exhaust emission at Maximum, Centre and Minimum for 9° of Taper turn in CAM in MPFI engine.**

SL NO	Diameter of the CAM (mm)	Valve lift in mm	Exhaust Emission of CO	Exhaust Emission of HC	Exhaust Emission of CO <sub>2</sub>
1	35.74(Maximum)	7.319	0.648	346	11.62
2	34.47(Centre)	5.925	0.398	136	11.30
3	33.45(Minimum)	3.961	0.247	85	10.43

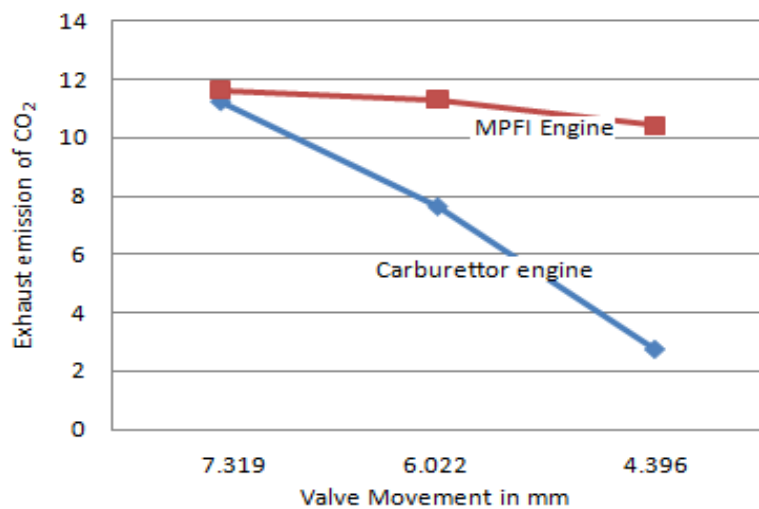




**Fig 10: Valve Movement V/S Exhaust emission of CO**



**Fig 11: Valve Movement V/S Exhaust emission of HC**



**Fig 12: Valve Movement V/S Exhaust emission of CO<sub>2</sub>**

The above figures clearly point out the exhaust gas emissions are reduced for the MPFI engine is compared to the carburettor engine with the use of flexible valve actuation mechanism.

## CONCLUSION

A fully flexible valve actuation system of  $8^{\circ}$  and  $9^{\circ}$  taper turn in CAM is conceived and designed. So as to give variable valve displacement, flexibility and can be controlled.

Emission characteristics for a modified cam have been studied at variable valve displacement depending on the operating conditions of the engine viz., minimum valve displacement at lean loads/low engine speeds, medium valve displacement at intermediate loads and maximum valve displacement at high loads/high engine speeds.

Emission characteristics can be also controlled since the fuel efficiency is increased. So the emission is reduced at 3 different locations of the CAM Shaft as the valve movement is varied and controlled by using the modified CAM Shaft.

## REFERENCES

1. L. Mianzo and H. Peng, "Output feedback H preview control of an electromechanical valve actuator," *IEEE Trans. Control Syst. Technol.*, Apr. 2007; 15(3): 428–437.
2. Eid Mohamed "Modeling and performance evaluation of an electromechanical valve actuator for a camless IC engine", *International Journal of Energy and environment*, 2012; 3(2): 275-294.
3. Mr.Paresh K. Kasundra, Prof. Ashish V. Gohil, "Performance Test of CI Engine with Different Vegetable Oil as a Fuel" *International Journal of Engineering Trends and Technology*, 2011; 2(3).
4. S. Naga Sarada, M.Shailaja, A.V. Sita Rama Raju, K. Kalyani Radha "Optimization of injection pressure for a compression ignition engine with cotton seed oil as an alternate fuel" *International Journal of Engineering, Science and Technology*, 2010; 2(6): 142-149.
5. Kern Y. Kang, Je H. Baek "Turbulence characteristics of tumble flow in a four-valve engine". *Experimental Thermal and Fluid Science*, 1998; 18: 231-243.
6. G Lakshmi Narayana Rao, S Sampath, K Rajagopal "Experimental Studies on the Combustion and Emission Characteristics of a Diesel Engine Fuelled with Used Cooking Oil Methyl Ester and its Diesel Blends" *World Academy of Science, Engineering and Technology*, 2008; 37.

7. J. Tsai, C. R. Koch, and M. Saif, “Cycle adaptive feedforward approach control of an electromagnetic valve actuator,” in *Proc. 47th IEEE Conf. Decision Control*, Cancun, Mexico, 2008: 5698–5703.
8. Kwanhee Choi, Hyungmin Lee, In Goo Hwang, Cha-Lee Myung and Simsoo Park, “Effects of various intake valve timings and spark timings on combustion, cyclic THC and NOX emissions during cold start phase with idle operation in CVVT engine”, *Journal of Mechanical Science and Technology*, 2008; 22: 2254-2262.
9. Liao Shiyong, Jiang Deming, Gao Jian and Zeng Ke “Effects of different frequency components in turbulence on accelerating turbulent premixed Combustion” *Proceedings of the Institution of Mechanical Engineers, Part D: Journal of Automobile Engineering*, 2003; 217: 1023.