

## STATIC ANALYSIS OF FOUR STROKE GASOLINE ENGINE PISTON FOR DIFFERENT MATERIALS BY USING FE ANALYSIS

G. Muni Rathnam<sup>1</sup> and Dr. B. Jayachandraiah<sup>2\*</sup>

<sup>1</sup>PG Scholar, Mechanical engineering, Srialahastheeswara Institute of Technology, India.

<sup>2</sup>Professor, Mechanical Engineering, Srialahastheeswara Institute of Technology, Srialahasti, India.

Article Received on 05/07/2018

Article Revised on 26/07/2018

Article Accepted on 16/08/2018

### \*Corresponding Author

**Dr. B. Jayachandraiah**

Professor, Mechanical

Engineering,

Srialahastheeswara

Institute of Technology,

Srialahasti, India.

### ABSTRACT

Engine pistons are one of the most complex components in the automobiles. The Engine can be called as heart of the Automobile and Piston may be considered as vital part of the Engine. There were lots of research works progresses for Engine piston and for new geometries in manufacturing methods and assessment, as piston exposes to high temperatures and maximum stresses. An attempt is made in this paper

to carryout static analysis of Four Stroke Gasoline Engine piston by Using different materials such as Aluminum Alloy (AA2618), Steel Alloy (AISI4340) and Titanium Alloy (Ti-6Al-4V). The dimensions of the piston are 80mm in diameter, 80mm in length, Top land width of 8mm, two compression rings of thickness 2.5mm and 2.5mm and Oil ring thickness of 5mm. First the piston is modeled by using CATIA V5 software, then meshing and analysis is done by ABAQUS CAE Software by using FE Analysis. The static analysis is done by applying different pressures 5MPa, 10MPa and 15MPa for different materials. The results are drawn for the different pressures of piston contour of von-misses stresses and displacements for Aluminum Alloy AA2618, Steel Alloy AISI 4340 and Titanium Alloy Ti-6M-4V. Further it is observed that Aluminum Alloy AA2618 at different pressures of 5MPa, 10MPa and 15MPa maximum Von-misses stress are 230.504MPa, 461.222MPa and 692.158MPa then displacements are 0.072mm, 0.144mm and 0.217mm respectively. Similarly for Steel Alloy AISI 4340 at different pressures of 5MPa,10MPa and 15MPa, maximum Von-misses stresses are 241.74MPa, 463.563MPa and 695.446MPa then displacements are 0.027mm, 0.055mm

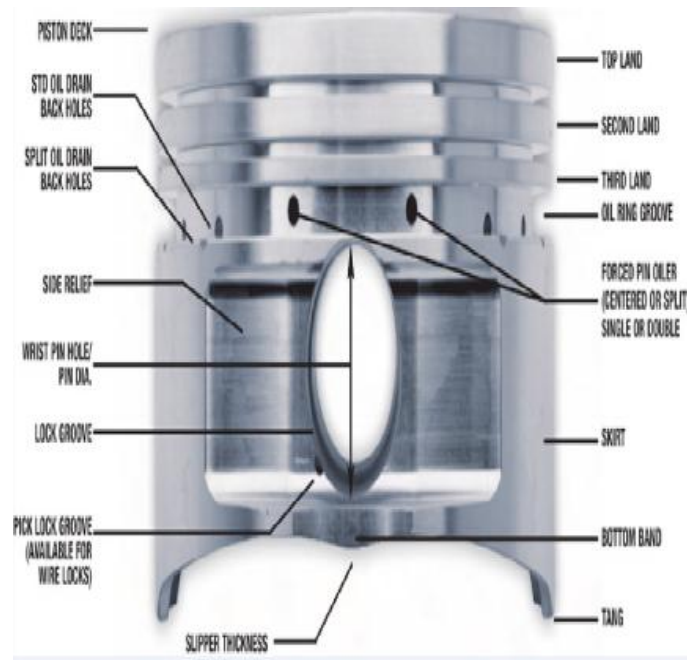
and 0.082mm respectively and for Titanium Alloy Ti-6Al-4V at different pressures of 5MPa, 10MPa and 15MPa maximum von-mises stresses are 228.89MPa, 457.897MPa and 694.463MPa then displacements are 0.050mm, 0.101mm and 0.135mm respectively. From the above results, it is observed that the best material for static analysis is Steel Alloy AISI 4340.

**KEYWORDS:** Piston, FE Analysis, Aluminum Alloy, Steel Alloy, Titanium Alloy.

## 1. INTRODUCTION

An Engine is a device which transforms the chemical energy of fuel into thermal energy and to produce mechanical work. Piston is considered to be one of the most important parts in a reciprocating engine in which it helps to convert the chemical energy obtained by the combustion of fuel into useful mechanical power. In general, a piston is a lubricated sliding shaft that fits tightly inside the opening of a cylinder. It is equipped with piston ring to provide a good seal between cylinder valve and piston. Although the piston appears to be a simple part, it is actually quite complex from the design stand point. The efficiency and the economy of the engine primarily depend on the working of piston. It must operate in the cylinder with minimum friction and should be able to withstand the high explosive force developed in the cylinder and also the very high temperature ranging from 22300°C to over 3000°C during operation. The piston should be as strong as possible, however, its weight minimized as far as possible in order to reduce the inertia due to its Reciprocating mass.

The top of the piston is called head or crown. Generally, low cost, low performance engines have flat head. In some other engines, the piston may be specially designed to form a desired shape of the combustion chamber, jointly with cylinder head, in case of piston containing part of combustion chamber in its crown, compression ratio can be controlled very accurately



**Fig. 1: Basic Components of A Piston.**

**Table 1: Different Material Alloys of the of Piston.**

<b>Piston materials</b>	<b>AA 2618</b>	<b>AISI4340</b>	<b>Ti – 6AL – 4V</b>
Density (kg/m <sup>3</sup> )	2.8	8.03	4.512
Elastic modulus (MPa)	80000	210000	113000
Poisson ratio	0.33	0.30	0.37
Thermal conductivity (W/m-K)	146	44.5	7.1

### 1.1 MATERIALS FOR PISTON

The material used for piston is mainly aluminum alloy. Aluminum pistons can be either cast or forged. Cast iron is also used for piston. In early years cast iron was almost universal material for pistons because it possesses excellent wearing, qualities, coefficient of expansion and general suitability in manufacture. Aluminum is inferior to cast iron in strength and wearing qualities and its greater coefficient of expansion necessitates greater clearance in the cylinder to avoid the risk of seizure. The heat conductivity of aluminum is about three times that of cast iron and this combined with the greater thickness necessary for strength, enables and aluminum alloy piston to run at much lower temperature than a cast iron one (200°C to 250°C as compared with 400°C to 450°C). As a result carbonized oil does not form on the underside of the piston and the crankcase therefore keeps cleaner.

### 1.2 Composition of AA2618 Material.

<b>Element</b>	<b>Al</b>	<b>Mg</b>	<b>Fe</b>	<b>Si</b>	<b>Cu</b>	<b>Ni</b>	<b>Ti</b>
<b>Weight %</b>	<b>93.7</b>	<b>1.60</b>	<b>1.1</b>	<b>0.18</b>	<b>2.30</b>	<b>1.0</b>	<b>0.07</b>

### 1.3 Composition of AISI 4340 Material.

Element	C	Mn	Si	P	S	Cr	Ni	Mo
Weight %	0.38-0.43	0.6.0.8	0.15-0.30	0.035 Max	0.04 Max	0.70-0.90	1.65-2.0	0.20-0.30

### 1.4 Composition of Ti-6Al-4V Material.

Element	Al	V	C	Fe	O	N
Weight %	5.5 – 6.75	3.5-4.5	0.10Max	0.30 Max	0.02 Max	0.05 Max

## 2. LITERATURE SURVEY

In modern trend automobile components are in great demand because of increase in usage of automobiles due to the improved performance & cost reduction of components. The purpose of literature survey of past research effort such as journals or articles related to static analysis of the Gasoline piston and use of FEM/ABAQUS for analysis move over, review of other relevant research studies are made to provide more information in order to understand more on this research. **Hitesh Pandey et al.**<sup>[1]</sup> has done the thermal analysis of a Speculative IC engine piston using CAE (Computer Aided Engineering) tools for different materials of a cast iron, structural steel, A2618 Al alloys. Aluminum alloy should provide good mechanical, minimum thermal stress and high heat conductivity. The results is comparison between theoretical and analysis simulated done and found approximately same. **Nitin Kumar et al.**<sup>[2]</sup> have done the stress distribution and deformation on piston of IC engine by using FEA. The piston model is created by using CREO Software. The FEA is performed with using ABAQUS Software. in this analysis maximum values of equivalent stresses goes up to  $7.444 \times 10 \text{ N/mm}^2$  due to applications of 18 Mpa gas pressure in crown of piston. **K. Anusha et al.**<sup>[3]</sup> has done by the thermal analysis of 4 – stroke Direct Injection diesel engine piston by using NASA398 as a piston material. The model is done in CATIA V5 Software. This model is meshed in hypermesh Software it can be analyzed by using FEA analysis ABAQUS SOFTWARE and applying the boundary conditions. **M. Nageswari et al.**<sup>[4]</sup> have done by design and analysis of both static and steady state thermal on piston head, they have designed piston using CAD software namely CATIA V5 and analysis is done using ANSYS 14.5 and the thermal and static analysis. It was analyzed piston with aluminum alloy material immersed with material namely zirconium and MgSi in place of silicon for better thermal conditions and deformation factors. **Swati S Chougule and Vinayak H Khatawate.**<sup>[5]</sup> has done the stress distribution of the Aluminum piston by using CAE software to the two stroke single cylinder engine of SUZUKI Max100 motorcycle. CAD software PRO-E Wildfire 4.0 is used to model the piston and analysis done by using ANSYS 14.

**Objective of the Paper:** In this paper the static analysis of piston by using different material such as Aluminum Alloy (AA2618 and AA4032), Titanium Alloy (Ti-6Al-4V) and Steel Alloy (AISI 4340) is carried out. The piston model is done in CATIA V5 Software and then analysis carried out using ABAQUS CAE software.

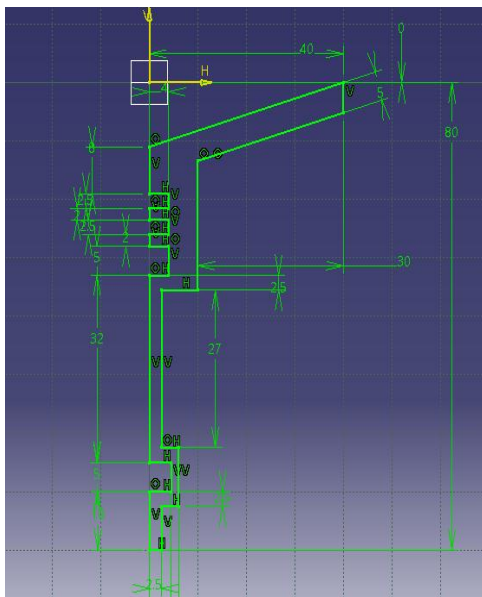
### 3. Data Collection

**Table 2: Geometrical entities of the piston.**

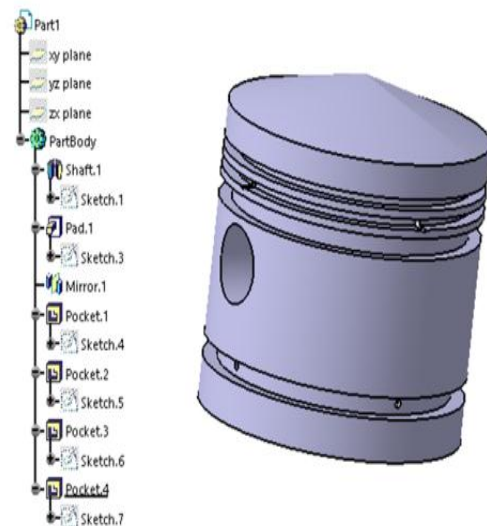
S. No.	Description	UNIT	VALUE
1.	Length of the Piston	mm	80
2.	Bore (Dia)	mm	80
3.	Thickness of the piston head( $t_H$ )	mm	4
4.	Radial thickness of the ring( $t_1$ )	mm	5.24
5.	Axial thickness of the ring( $t_2$ )	mm	5
6.	Width of the top land ( $b_1$ )	mm	8
7.	Width of other ring lands( $b_2$ )	mm	4

### 4. Modeling and Finite Element Analysis

Increase in computational power of modern computers, CATIA V5 has found more and more applications in the Gasoline engine design and development. In this chapter mainly discussed detailed view of CATIA SOFTWARE introduction, applications, and its design data and also piston model is developed in CATIA V5 and then imported to Abacus CAE Software.



**Fig. 2: 2D Piston Design Model.**



**Fig. 3: Isometric view of Piston Model in CATIA.**

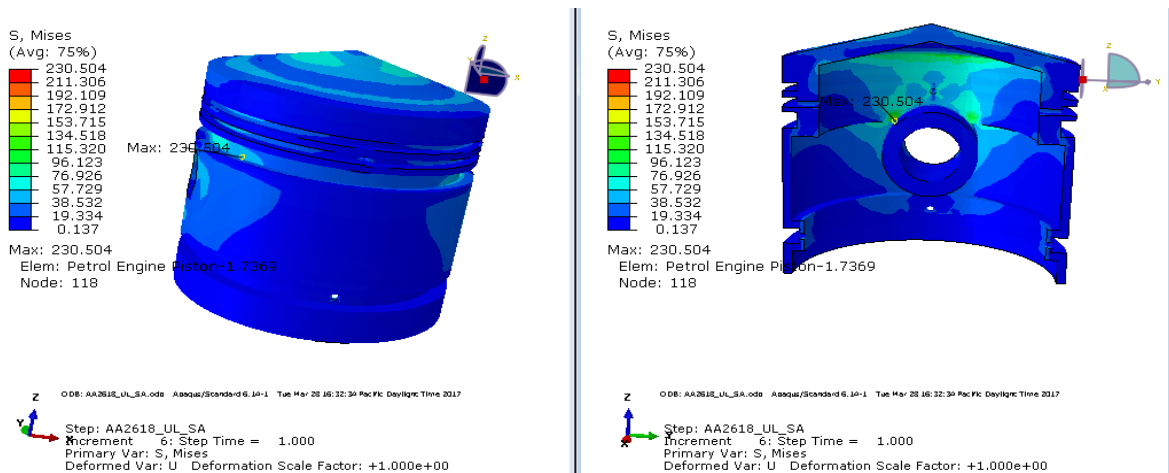
### 5. RESULTS AND DISCUSSIONS

The results are drawn for Von – Misses stress, displacement on four stroke gasoline engine piston for different materials (AA2618, AISI4340, and Ti - 6Al - 4V). The following are the

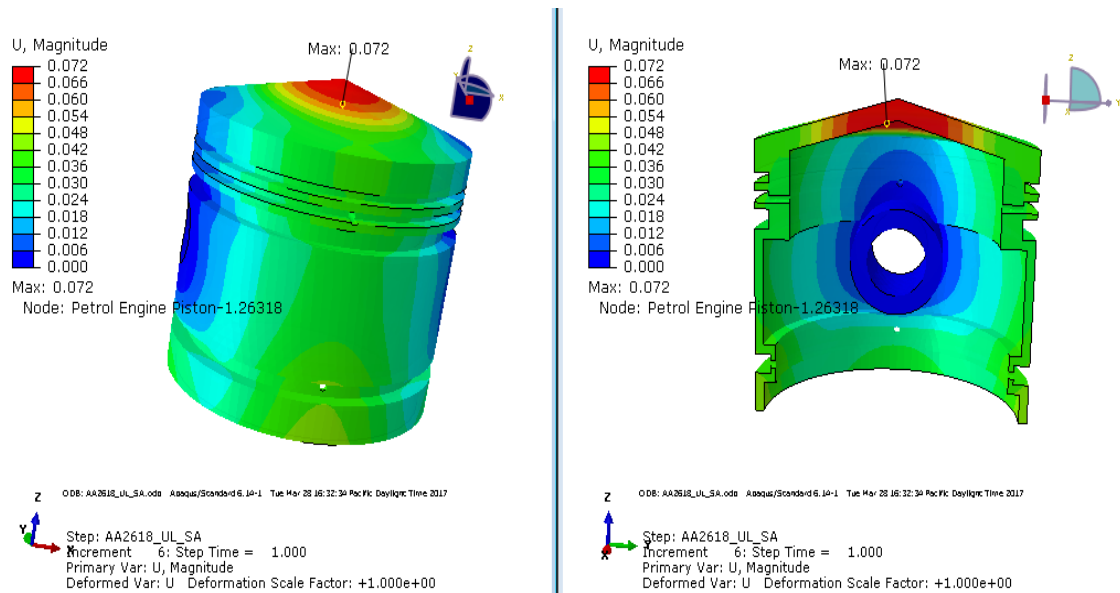
results obtained from the static analysis. In static analysis apply the all mechanical properties on the piston such as density, young’s modulus and Poisson’s ratio. The piston pin hole is fixed and finally 5 Mpa, 10Mpa, 15Mpa pressure is applying on surface of the piston.

**5.1 Case 1: AA 2618 Alloy**

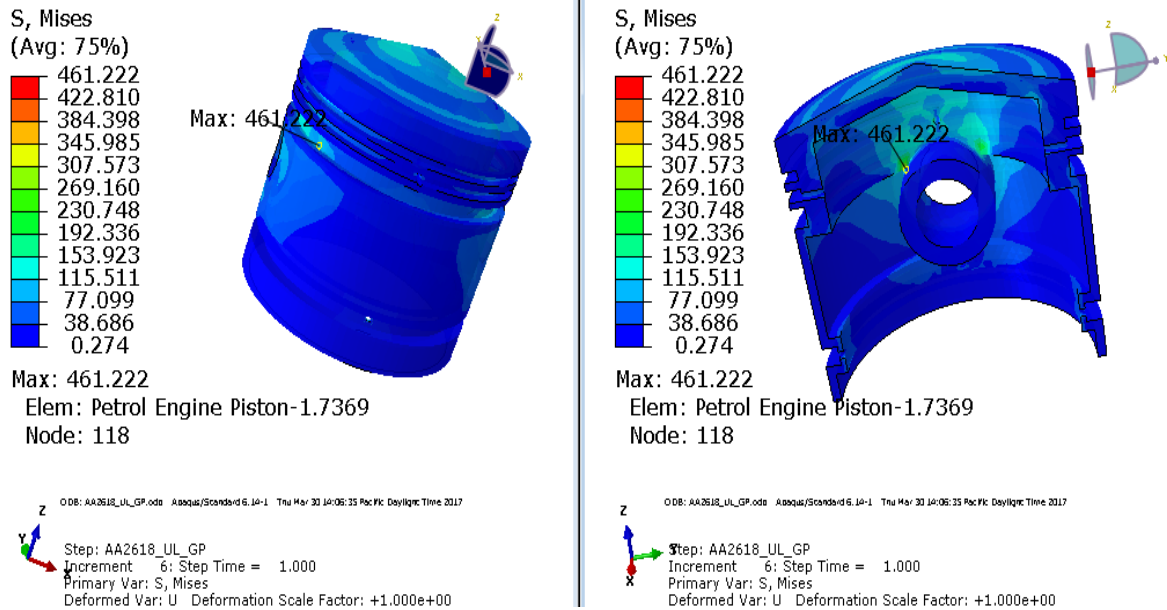
At 5 Mpa injection pressure, the stress distribution contours and displacement distribution contours as shown in below figure for the alloy of AA2618 material. The maximum stress is 230.504Mpa and maximum displacement is 0.072mm is attained.



**Fig. 4: The stress distribution contours for AA2618 material at 5Mpa pressure.**

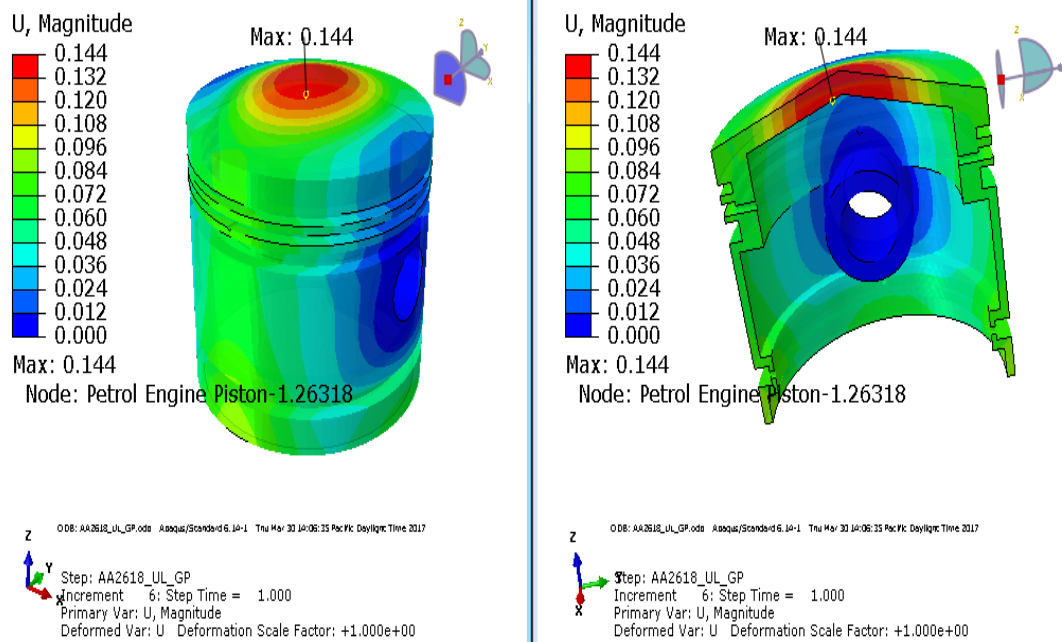


**Fig. 5: The displacement distribution contours for AA2618 material at 5Mpa pressure.**



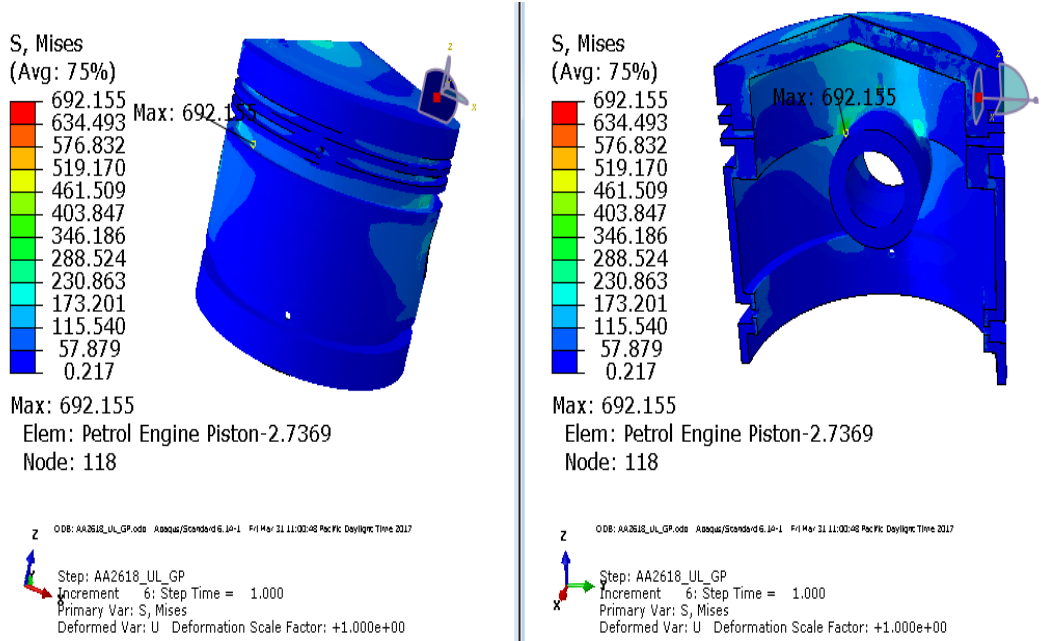
**Fig 6: The stress distribution contours for AA2618 material at 10Mpa pressure.**

At 10Mpa injection pressure, the stress distribution contours and displacement distribution contours as Shown in below figure for the alloy of AA2618 material. The maximum stress is 461.222Mpa and maximum displacement is 0.144 mm is attained.

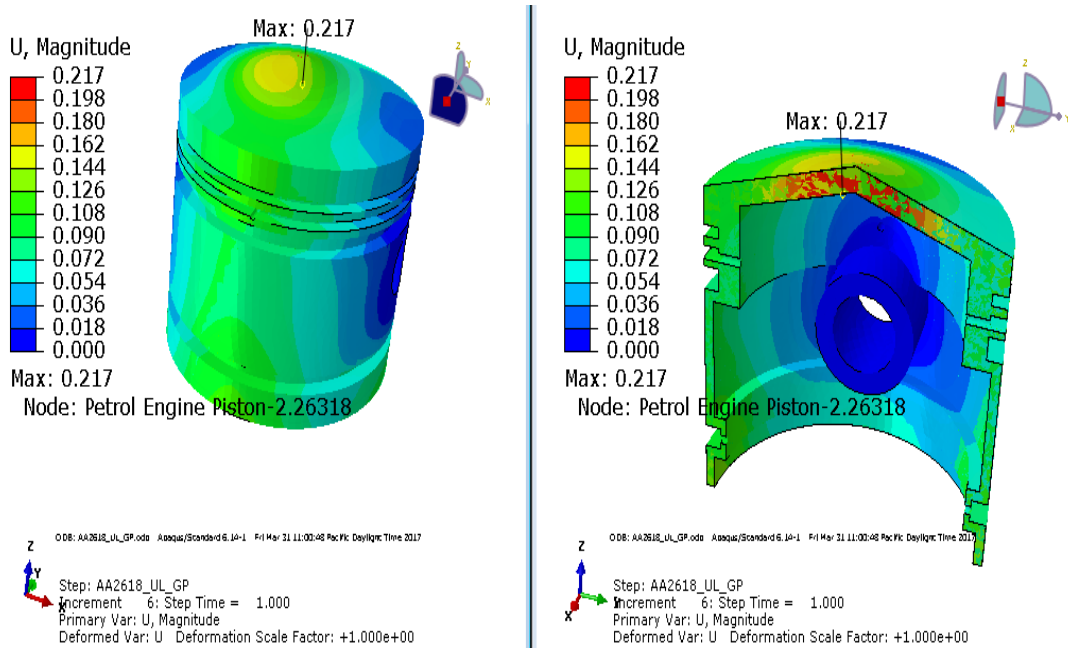


**Fig 7: The Displacement distribution contours for AA2618 material at 10Mpa pressure.**

At 15Mpa injection pressure, the stress distribution contours and displacement distribution contours as shown in below figure for the alloy of AA2618 material. The maximum stress is 692.155Mpa and maximum displacement is 0.217 mm is attained.



**Fig. 8: The stress distribution contours for AA2618 material at 15Mpa pressure.**



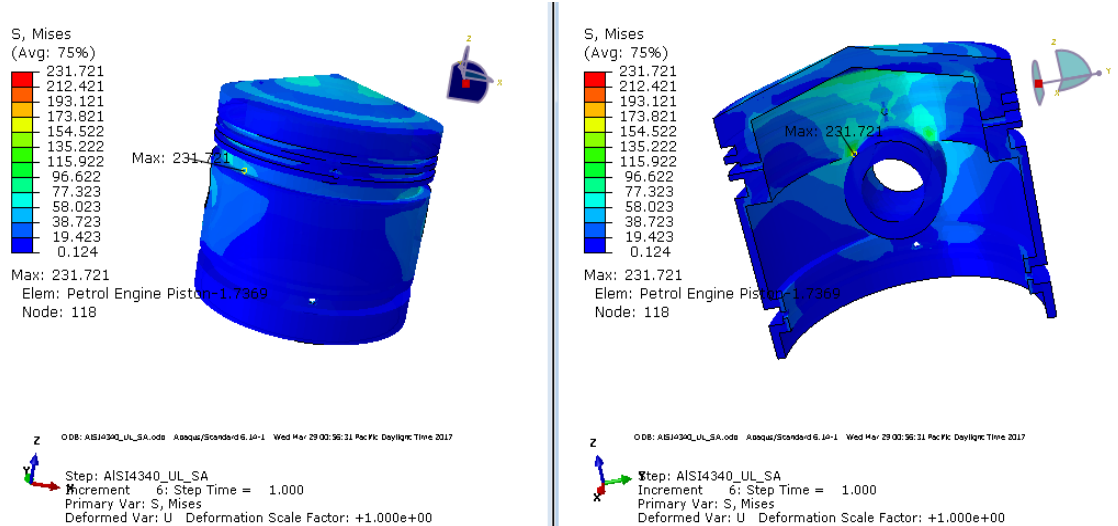
**Fig. 9: The Displacement distribution contours for AA2618 material at 15Mpa pressure.**

For the AA2618 material stress distribution is increases with increase in pressure and Displacement distribution is also increases.

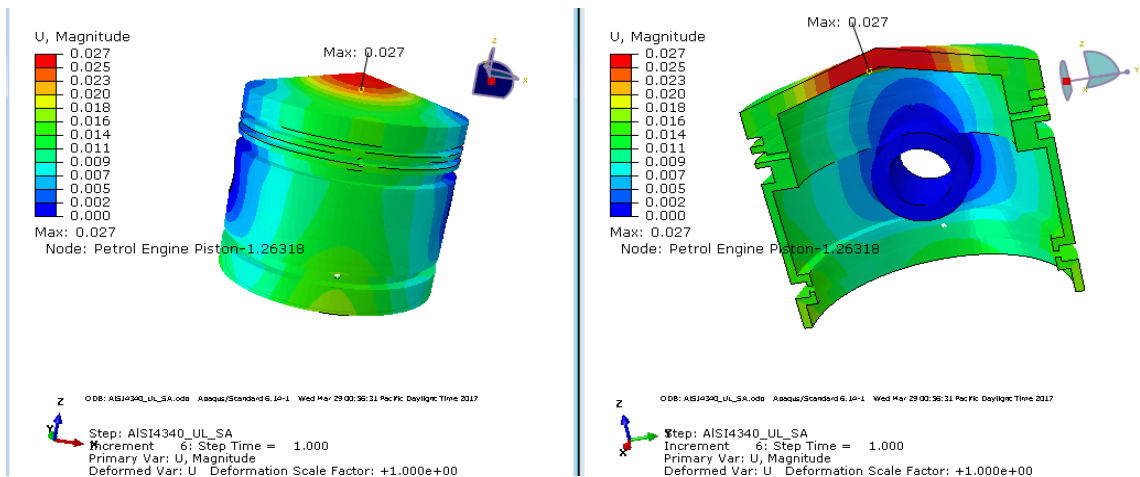
**5.2 Case 2: AISI 4340 Alloy**

At 5Mpa injection pressure, the stress distribution contours and displacement distribution contours as shown in below figure for the alloy of AISI4340 material. The maximum stress is 231.721Mpa and maximum displacement is 0.027 mm is attained.

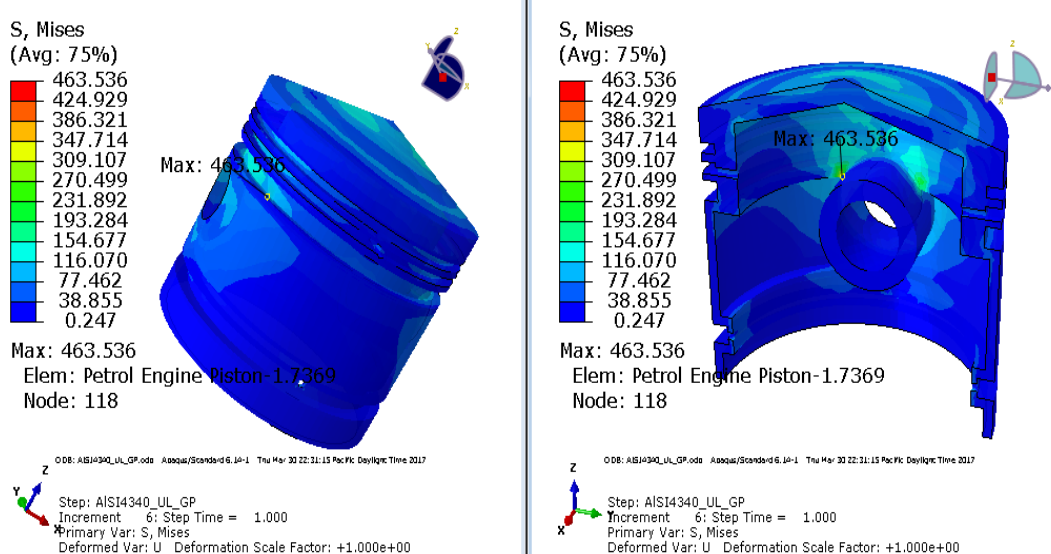




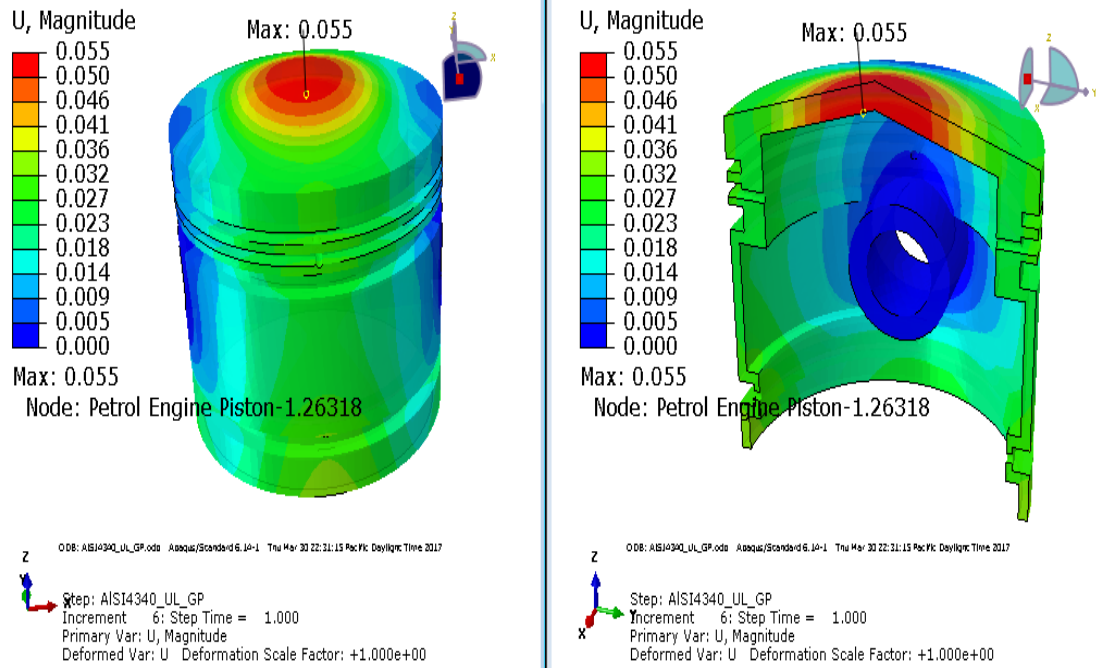
**Fig. 10: The stress distribution contours for AISI4340 material at 5Mpa pressure.**



**Fig. 11: The Displacement distribution contours for AISI4340 material at 5Mpa pressure.**

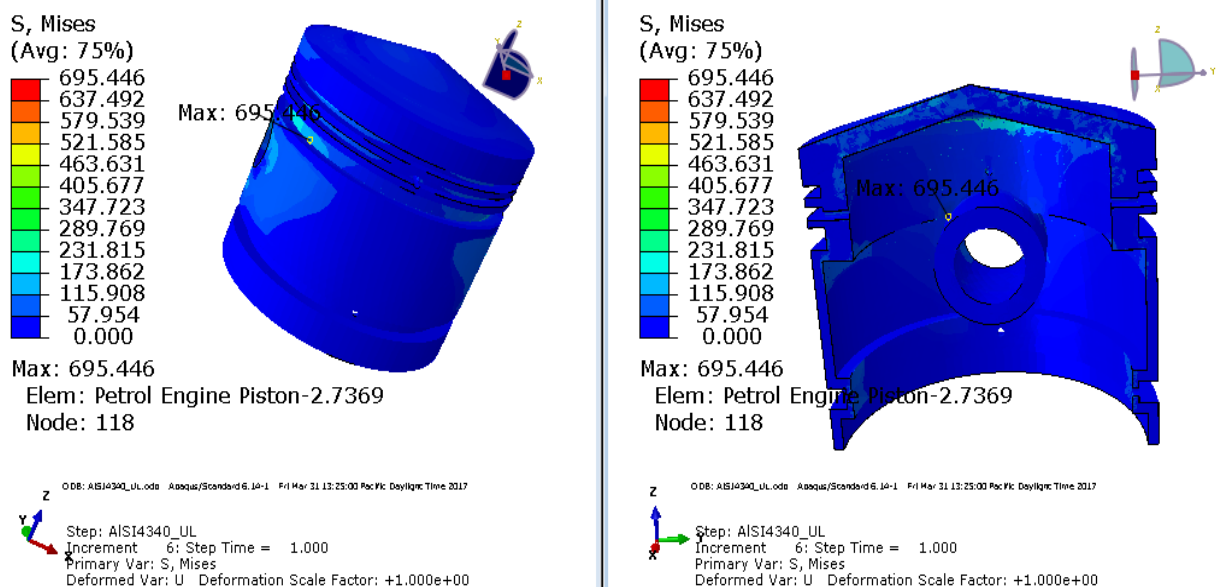


**Fig. 12: The Stress distribution contours for AISI 4340 material at 10Mpa pressure.**

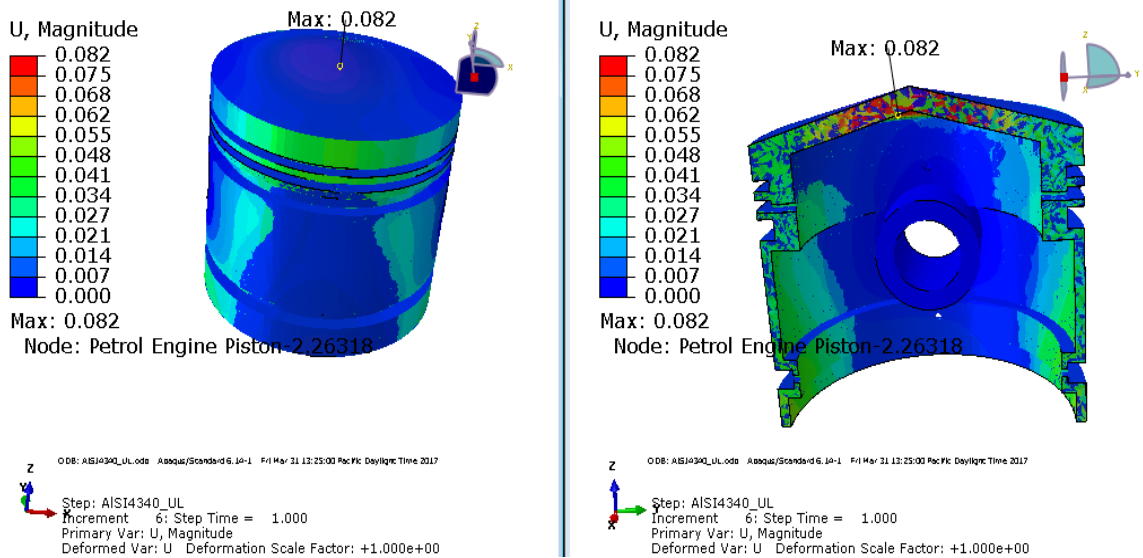


**Fig. 13: The Displacement distribution contours for AISI4340 material at 10Mpa pressure.**

At 10Mpa injection pressure, the stress distribution contours and displacement distribution contours as shown in below figure for the alloy of AISI4340 material. The maximum stress is 463.536Mpa and maximum displacement is 0.055 mm is attained.



**Fig. 14: The Stress distribution contours for AISI4340 material at 15 Mpa pressure.**

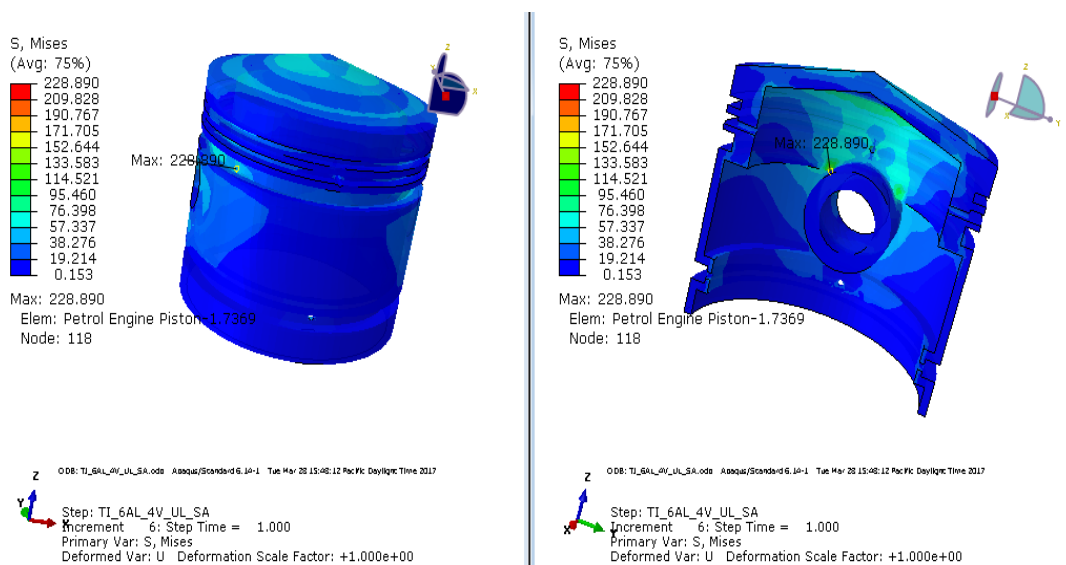


**Fig. 15: Displacement distribution contours for AISI4340 material at 15 Mpa pressure**

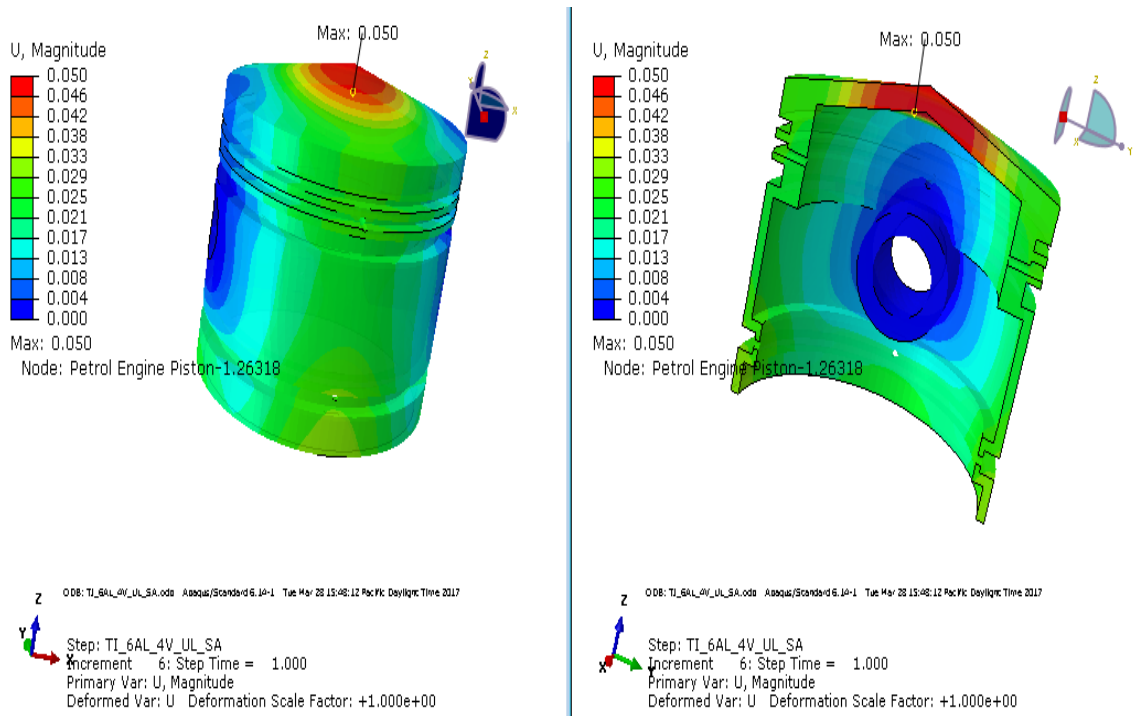
At 15Mpa injection pressure, the stress distribution contours and displacement distribution contours as shown in below figure for the alloy of AISI4340 material. The maximum stress is 695.446Mpa and maximum displacement is 0.082 mm is attained. For the AISI4340 material stress distribution is increases with increase in pressure and Displacement distribution is also increases.

**5.3 CASE 3: Ti – 6Al – 4V ALLOY**

At 5Mpa injection pressure, the stress distribution contours and displacement distribution contours as shown in below figure for the alloy of Ti -6Al – 4V material. The maximum stress is 228.890Mpa and maximum displacement is 0.050 mm is attained.

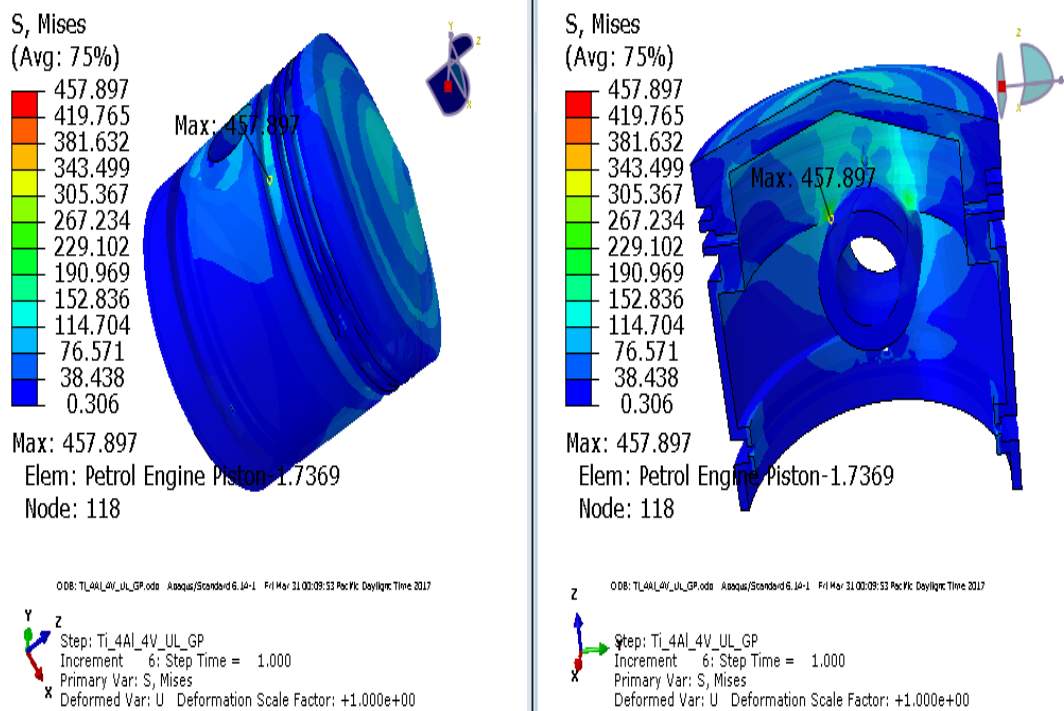


**Fig. 16: The Stress distribution contours for Ti – 6Al – 4V material at 5Mpa pressure.**

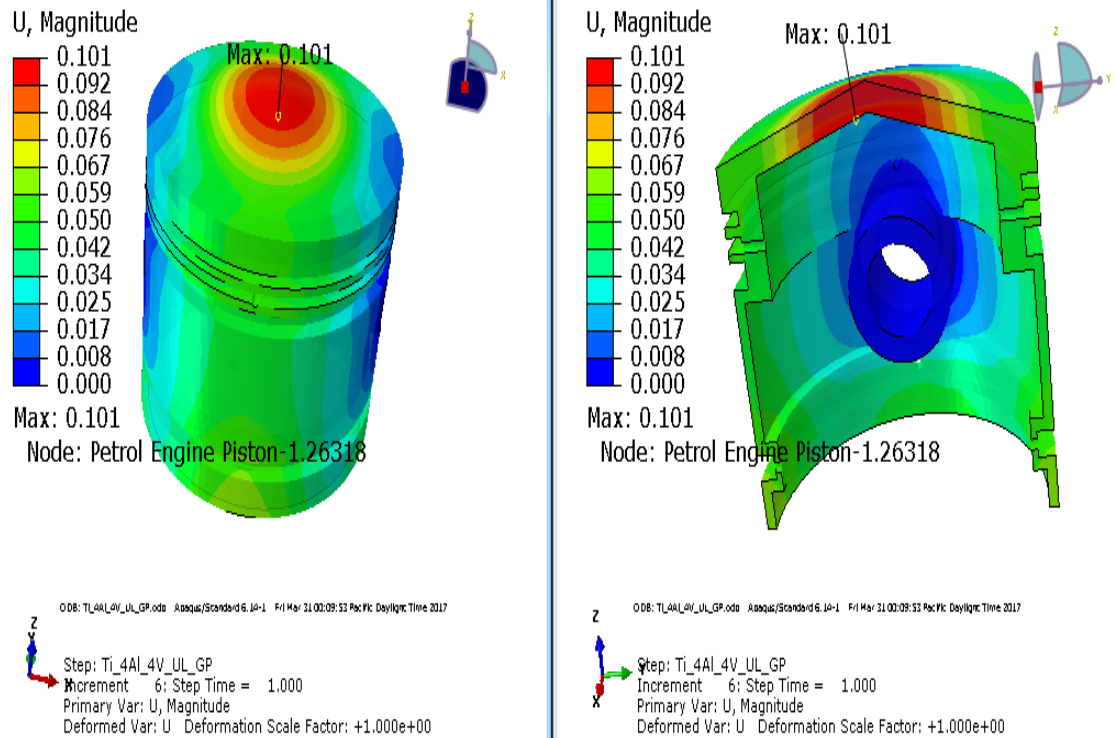


**Fig. 17: The Displacement distribution contours for Ti – 6Al – 4V material at 5Mpa.**

At 10Mpa injection pressure, the stress distribution contours and displacement distribution contours as shown in below figure for the alloy of Ti -6Al – 4V material. The maximum stress is 457.89Mpa and maximum displacement is 0.101mm is attained.

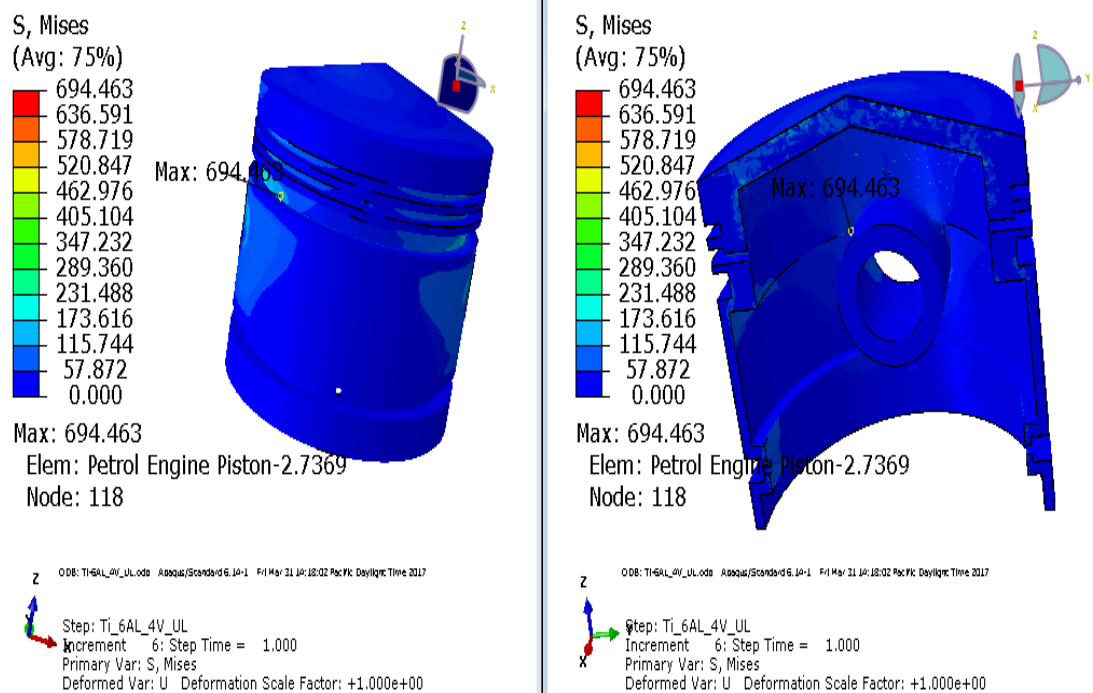


**Fig. 18: The Stress distribution contours for Ti – 6Al – 4V material at 10Mpa.**

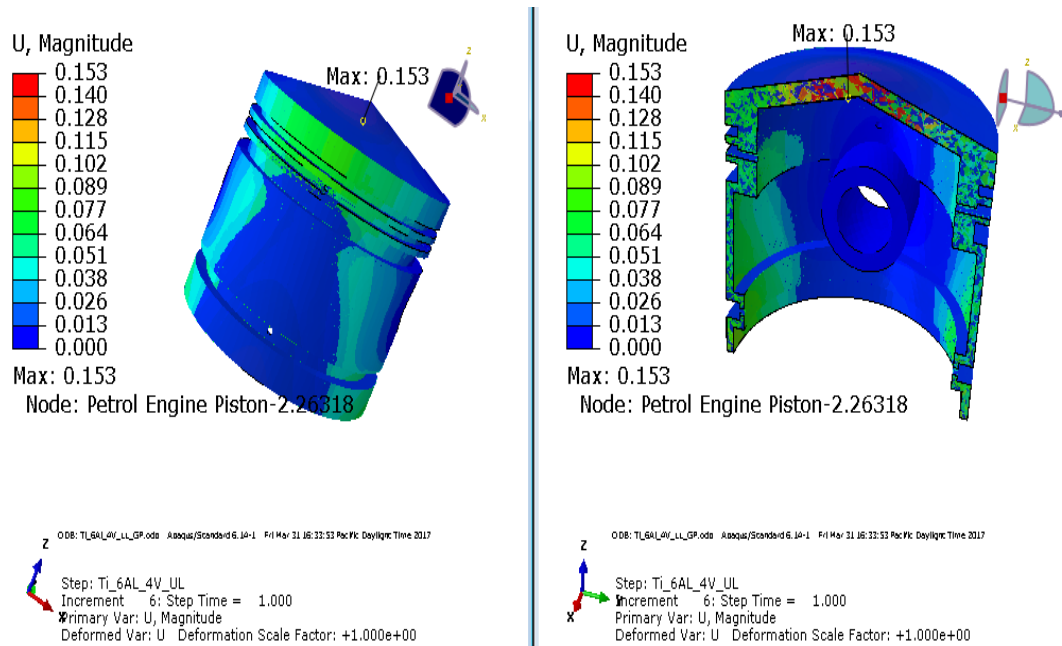


**Fig. 19: The Displacement distribution contours for Ti – 6Al – 4V material at 10Mpa.**

At 15Mpa injection pressure, the stress distribution contours and displacement distribution contours as shown in below figure for the alloy of Ti -6Al – 4V material. The maximum stress is 694.463Mpa and maximum displacement is 0.153 mm is attained.



**Fig. 20: The Stress distribution contours for Ti – 6Al – 4V material at 15Mpa pressure.**



**Fig. 21: The Displacement distribution contours for Ti – 6Al – 4V material at 15Mpa.**

For the Ti – 6Al – 4V material stress distribution is increases with increase in pressure and Displacement distribution is also increases.

## 6. CONCLUSION

Investigated the static analysis of Four stroke gasoline Engine Piston by using different Piston materials such as Aluminum Alloy (AA2618), Titanium Alloy (Ti-6Al-4V) and Steel Alloy (AISI 4340) at different Pressure 5Mpa, 10Mpa and 15Mpa. It is observed that for the Aluminum Alloy AA2618 at different pressures of 5MPa, 10MPa and 15MPa the maximum Von-misses stress are 230.504MPa, 461.222MPa and 692.158MPa then displacements are 0.072mm, 0.144mm and 0.217mm respectively. Similarly for Steel Alloy AISI 4340 at different pressures of 5MPa, 10MPa and 15MPa, maximum Von-misses stresses are 241.74 MPa, 463.563 MPa and 695.446 MPa then displacements are 0.027mm, 0.055mm and 0.082mm respectively and for Titanium Alloy Ti-6Al-4V at different pressures of 5MPa, 10MPa and 15MPa maximum von-misses stresses are 228.89MPa, 457.897MPa and 694.463 MPa then displacements are 0.050mm, 0.101mm and 0.135mm respectively. For the AA2618 material stress distribution is increases with increase in pressure and Displacement distribution is also increases. For the AISI4340 material stress distribution is increases with increase in pressure and Displacement distribution is also increases. For the Ti – 6Al – 4V material stress distribution is increases with increase in pressure and Displacement distribution is also increases. Further this work can be extended to Dynamic land Thermal Analysis.

**REFERENCES**

1. Hitesh Pandey, Avin Chandrakar, PM Bhagwat “Thermal Stress Analysis of Speculative IC Engine Piston using CAE Tools” *Int. Journal of engineering Research and Applications* ISSN: 2248-9622, November 2014; 4(11): 60-64.
2. Nitin Kumar, “Finite Element Analysis of Piston Head by ABAQUS”, *International Journal of Scientific & Engineering Research*, May-2015 24; 6(5): ISSN 2229-5518.
3. K. Anusha, Dr. B. Jayachandraiah “Thermal Analysis Of Four Stroke Diesel Ic Engine Piston By Using Abaqus Software” in, 2015.
4. M. Nageswari, “Thermal& Static Analysis on Ic Engine Piston Using FEA”, *International Journal of Advance Research in Scientific & Engineering*, DEC-2015; 4(12).
5. Swati S Chougule, Vinayak H Khatawate “The stress distribution of the Aluminium piston by using CAE software to the two stroke single cylinder engine of SUZUKI Max100 motorcycle”. *Hindawi Publishing Corporation Journal of Engineering*, 2015.
6. Vivek Zolekar, Dr. L. N. Wankhade “Finite Element Analysis and Optimization of Engine Piston using RADIOSS and OptiStruct, Altair Technology Conference, 2013 INDIA. Neethu Sharma, “Design and Thermal Analysis on A Piston Of An Engine”, 2015; 2(4).
7. B. A Devan, “Thermal analysis of Aluminum alloy Piston” *International Journal of Emerging Trends in Engineering Research (IJETER)*, 2015; 3(6): 511 – 515.
8. S. Bhattacharya, “Analysis Of Piston Of Two Stroke Engine”, *International Journal Of Research In Engineering And Technology*, Jun-2014; 03(6).