

FOG COMPUTING: NEW ERA IN CLOUD COMPUTING INFRASTRUCTURE

Dr. Anand Mohan*

Associate Professor, NSHM Knowledge Campus, Durgapur -713212 (West Bengal).

Article Received on 30/10/2018

Article Revised on 20/11/2018

Article Accepted on 11/12/2018

***Corresponding Author**

Dr. Anand Mohan

Associate Professor, NSHM
Knowledge Campus,
Durgapur -713212 (West
Bengal).

ABSTRACT

FOG Computing is an advanced or extended version of cloud computing where the computing takes place at the edge of the network. Even though the increasing usage of cloud computing, there are many more issues unsolved due to the intrinsic problem of cloud computing such as changeable potential, lack of mobility support and location-

awareness. It is similar to cloud computing, but is far denser in geographical distribution and location and its proximity to end users is more, which means they provide a faster end-user experience than cloud computing and have better performance. Fog computing, also termed edge computing, can address those problems by providing elastic resources and services to end users at the edge of network, while cloud computing is more about providing resources distributed in the core network. In fact, the cloudlet concept is a subset of edge computing applied to mobile networks and the fog concept is a subset of edge computing applied to Internet of Things (IoT). FOG leverages all the advantages of cloud, but is far denser than it with more geographical reach and cover This paper discusses the definition of fog computing and similar concepts, introduces representative application scenarios, and identifies various aspects of issues of fog computing systems. Paper also discuss openings and challenges.

KEYWORDS: Fog computing, edge computing, cloud computing, mobile edge computing mobile cloud computing.

INTRODUCTION

Fog computing may be a term generated by Cisco refers to increasing cloud computing to the enterprise's edge network, thus enabling a new breed of applications and services. fog computing provides the accomplishment of storage, calculate and networking service between cloud computing knowledge centres and end services. Fog computing, otherwise called fog networking or hazing, is a decentralized registering foundation in which information, figure, stockpiling and applications are dispersed in the most legitimate, productive place between the information source and the cloud.

Despite the broad utilization of cloud computing, some applications and services still cannot benefit from this popular computing paradigm due to inherent problems of cloud computing such as unacceptable latency, lack of mobility support and location-awareness. As a result, fog computing, has emerged as a promising infrastructure to provide elastic resources at the edge of network.

Defining characteristics of the Fog are:

- a) Low latency and location awareness;
- b) Wide-spread geographical distribution;
- c) Mobility;
- d) Very large number of nodes,
- e) Predominant role of wireless access,
- f) Strong presence of streaming and real time applications,
- g) Heterogeneity.

Fog computing stretches out cloud computing and administrations to the edge of the system, bringing the points of interest and energy of the cloud nearer to where information is made and followed up on.

Cisco planned its fog computing vision in Jan 2014 as a way of transfer cloud computing skills to the top begin and as a result, nearer to the oftentimes increasing no. of interconnected applications and devices that consumes cloud adoption and manufactures additional and larger amounts of information. FOG computing bridges the gap between statistics centres operating in a normal Imperceptive computing design, and finish points. Extent production, as a result, it in addition to provides for a receive, take counsel there, waste gritty integral and a cautious result that accords process power, storage, and network service.

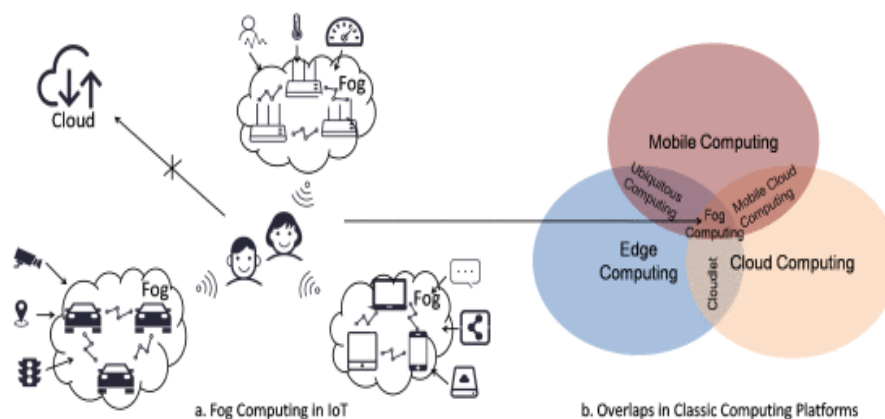

Figure 1: Description of fog computing: Fog computing is the central overlap of mobile computing, edge computing, and cloud computing.

Fog computing, also known as fog networking, is a kind of decentralized computing infrastructure in which computing resources and application services are distributed in a logical and efficient place at any point, along the continuum from the data source to the cloud. The most important goal of fog computing is to improve efficiency and reduce the amount of data that needs to be transported to the cloud for processing, analysis and storage. Although this is mostly done for efficiency reasons, it can also be done for security and compliance reasons.

Objective of fogging

The objective of fogging is to enhance productivity and decrease the amount of information transported to the cloud for preparing, investigation, and capacity. This is frequently done to enhance productivity; however, it might likewise be utilized for security and consistence reasons. Famous fog computing applications incorporate smart framework, smart city, smart buildings, vehicle systems and programming characterized systems.

The similitude fog originates from the meteorological term for a cloud near the ground, similarly as fog focuses on the edge of the system. The term is often connected with Cisco; the organization's product offering supervisor, Ginny Nichols, is accepted to have begat term. "Cisco Fog Computing" is an enrolled name; fog is available to the community at large.

Fog computing versus edge computing

In fog computing, transporting data from things to the cloud requires many steps.

1. First the electrical signals from things are traditionally wired to the I/O points of an automation controller (PLC or PAC). The automation controller executes a control system program to automate the things.

2. Next the data from the control system program is sent to an OPC server or protocol gateway, which converts the data into a protocol Internet systems understand, such as MQTT or HTTP.
3. Then the data is sent to another system, such as a fog node or IoT gateway on the LAN, which collects the data and performs higher-level processing and analysis. This system filters, analyses, processes, and may even store the data for transmission to the cloud or WAN at a later date.

So fog computing involves many layers of complexity and data conversion. Its architecture relies on many links in a communication chain to move data from the physical world of our assets into the digital world of information technology. In a fog computing architecture, each link in the communication chain is a potential point of failure.

Edge computing - Edge computing simplifies this communication chain and reduces potential points of failure. In edge computing, physical assets like pumps, motors, and generators are again physically wired into a control system where the PAC automates them by executing an on board control system program. Intelligent PACs with edge computing capabilities collect, analyze, and process data from the physical assets they're connected to at the same time they're running the control system program.

PACs then use edge computing capabilities to determine what data should be stored locally or sent to the cloud for further analysis. In edge computing, intelligence is literally pushed to the network edge, where our physical assets or things are first connected together and where IoT data originates. Edge computing saves time and money by streamlining IoT communication, reducing system and network architecture complexity, and decreasing the number of potential failure points in an IoT application. Reducing system architecture complexity is key to the success of IoT applications.

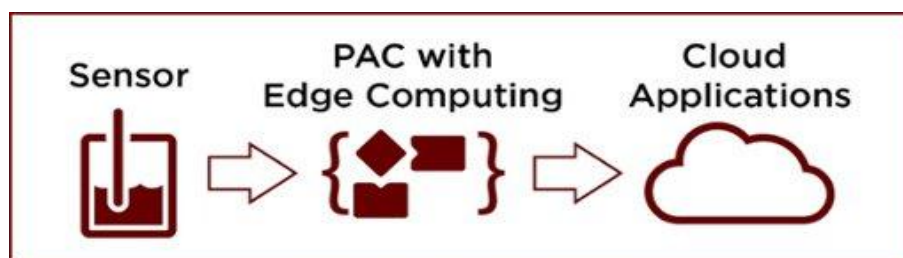

Fog computing architecture

A generic Fog computing architecture is shown in figure 2. It presents a hierarchical structure. The bottommost layer encompasses wireless, smart, mobile or fixed end-user's objects such as sensors, robots, smart phones, and cameras. Components from this layer use the above layer to connect with other elements (in the same layer) as well as with IoT services implemented in both network and Cloud layers. The network layer covers several sub-layers (network's edge, aggregation and core). It involves network components presents a hierarchical structure such as gateways, switches, routers, PoPs and base stations. This layer is used also for hosting IoT applications that require low latency as well as performing data aggregation, filtering and pre-processing before sending to the Cloud.

Finally, the last layer is the uppermost one, it involves powerful servers distributed within distant data-centres to host applications for big data analytics and permanent storage such as gateways such as gateways, switches, routers, PoPs and base stations. This layer is used also for hosting IoT applications that require low latency as well as performing data aggregation, filtering and pre-processing before sending to the Cloud. Finally, the last layer is the uppermost one, it involves powerful servers distributed within distant data-centres to host applications for big data analytics and permanent storage, switches, routers, PoPs and base stations.

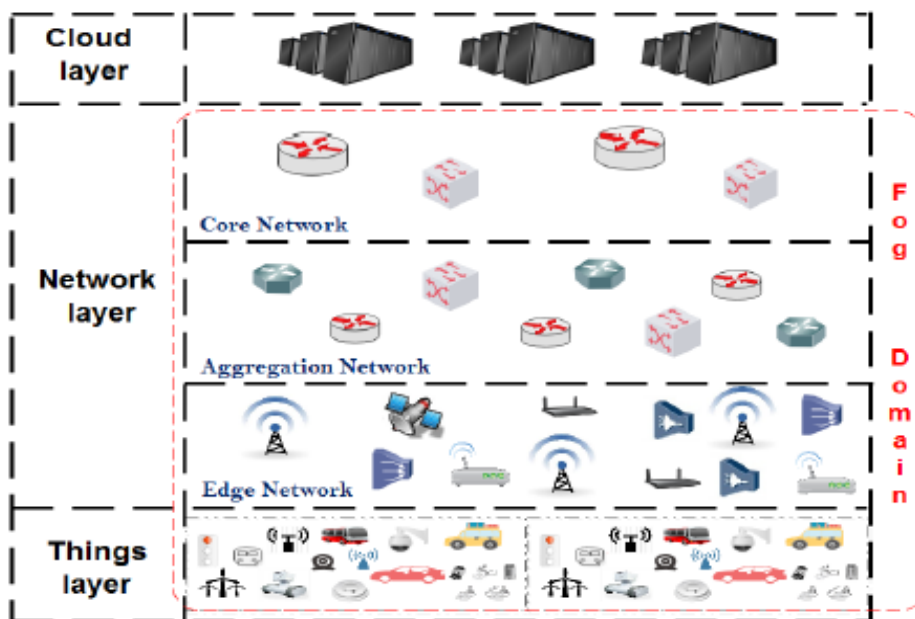

Figure 2: Fog Computing Architecture.

From Cloud to Fog Computing

Fog computing has been initially introduced in the telecommunication sector when researchers and practitioners realized how the role of the final users changed from consumers of information to prosumers (producers and consumers at the same time). In fact, the original paradigm on which the Web is based assumes that the core of the network is in charge of providing information that will be consumed at the edge. Prosumers with mobile devices or IoT sensors, however, generate immense data quantities at the edge of the network. So, what precisely is Fog Computing and how can it be distinguished from Edge Computing?

Edge Computing is exclusively about computation at the edge of the network without any notion of cloud services. Depending on the source, Fog Computing is either the same as Edge Computing or is defined as the amalgam of cloud, edge, and any intermediary nodes in between (this could be small- to medium-sized data centres within the core network of the network provider).

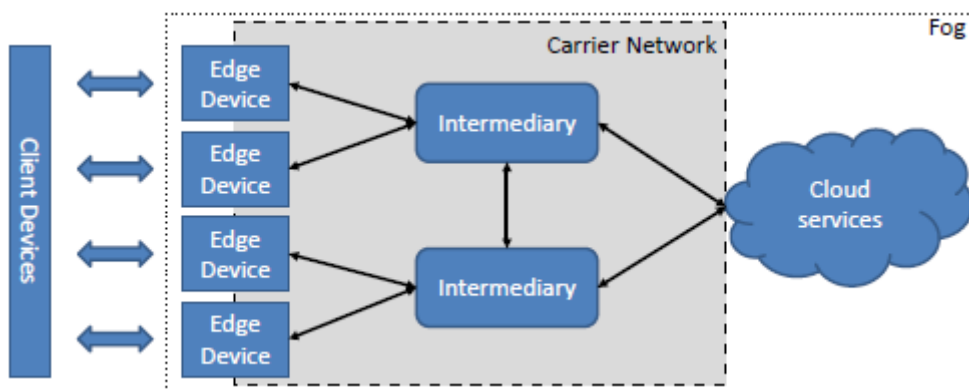

Figure 3: Deployment Overview of Fog Computing.

How fog computing works

While edge devices and sensors are where data is generated and collected, they don't have the compute and storage resources to perform advanced analytics and machine-learning tasks. Though cloud servers have the power to do these, they are often too far away to process the data and respond in a timely manner. In addition, having all endpoints connecting to and sending raw data to the cloud over the internet can have privacy, security and legal implications, especially when dealing with sensitive data subject to regulations in different countries.

In a fog environment, the processing takes place in a data hub on a smart device, or in a smart router or gateway, thus reducing the amount of data sent to the cloud. It is important to note that fog networking complements -- not replaces -- cloud computing; fogging allows for short-term analytics at the edge, and the cloud performs resource-intensive, longer-term analytics.

The fundamental objective of the Internet of Things (IoT) is to obtain and analyze data from assets that were previously disconnected from most data processing tools. This data is generated by physical assets or things deployed at the very edge of the network such as motors, light bulbs, generators, pumps, and relays—that perform specific tasks to support a business process. The Internet of Things is about connecting these unconnected devices (things) and sending their data to the cloud or Internet to be analysed.

In traditional IoT cloud architecture, all data from physical assets or things is transported to the cloud for storage and advanced analysis. Once in the cloud, the data is used for cognitive prognostics (that is, predictive maintenance, forensic failure analysis and process optimization).

Fog and edge computing in manufacturing and automation applications are network and system architectures that attempt to collect, analyse, and process data from these assets more efficiently than traditional cloud architecture. These architectures share similar objectives:

- To reduce the amount of data sent to the cloud.
- To decrease network and Internet latency.
- To improve system response time in remote mission-critical applications.

Edge gadgets and sensor don't have the procedure and limit advantages for performing an advanced examination, and machine-learning assignments when they are the place data is made and accumulated. The cloud servers are often far away to process the data and respond advantageously though the way that cloud servers can do these. As all endpoints are associated and sending unrefined data to the cover over the internet can have safeguard and safety most effectively while handling fragile data subject to headings in different countries.

The taking care of occurs in a data center of a fog space on a sharp device, or in a shrewd switch or entrance, with these lines decreasing the quantity of data dispatched to the cloud. Fog computing supplements not replace; inception considers at this very moment

examination, as well as the cloud functions resource genuine, durable examination. However, there is a key difference between the two concepts. Both fog computing and edge computing involve pushing intelligence and processing capabilities down closer to where the data originates—at the network edge.

The key difference between the two architectures is exactly where that intelligence and computing power is placed.

- **Fog computing** pushes intelligence down to the local area network (LAN) level of network architecture, processing data in a fog node or IoT gateway.
- **Edge computing** pushes the intelligence, processing power, and communication capabilities of an edge gateway or appliance directly into devices like PACs (programmable automation controllers).

In both architectures data is generated from the same source physical assets such as pumps, motors, relays, sensors, and so on. These devices perform a task in the physical world such as pumping water, switching electrical circuits, or sensing the world around them. These are the “things” that make up the Internet of Things.

Support of location awareness is the key difference between the cloud environment and the fog environment. Cloud computing serves as a centralized global model, so it lacks location awareness. In contrast to cloud computing, fog devices are physically situated in the vicinity of end users. Data sharing has great importance for many people, and it is an urgent need for organizations that aim to improve their productivity. Currently, there is an urgent need to develop data sharing applications, especially for mass com-

Fog Benefits

Perhaps the most cogent example of Fog Computing involves the Industrial Internet and the copious quantities of data that are generated via the real-time monitoring of continuously data generating equipment assets in any variety of industries. Fog computing can enable organizations to monitor that equipment at the source via real-time and predictive analytics—most of which will reveal that the equipment is operating as intended. Inordinate amounts of data are processed at the source without constraining an organization’s network resources by sending that data back and forth to a data center.

However, the moment the need for maintenance or failure is detected (or presaged via predictive analytics), that comparatively little amount of data indicating that there is a problem is transmitted to centralized facilities so appropriate action can occur. Additional Fog boons include:

Cost: The bandwidth required for regularly transmitting decentralized data (which could originate from anywhere in the country or in the world) to centralized locations is expensive and can create bottlenecks as various enterprise use cases contend for those same resources. Fog Computing requires significantly less movement of data, which frees up the network for other uses.

Expedience: By processing data closer to its source, Fog Computing can significantly expedite computations and processes—enabling organizations to go from chimeric ‘near real-time’ processing speeds to true real-time processing. Again, the proliferation of mobile devices and demands projected for the IoT make time a critical component of service delivery and customer satisfaction. IoT applications such as vehicle to vehicle communication require the least amount of latency as possible.

Security and Governance: The less frequently and the less distance that data has to travel, the more secure it is. Additionally, there are strict regulatory requirements about where data is stored and accessed (which vary by industry and country) to which local Fog Computing at the extremities of the Cloud can innately conform.

Drawbacks

Depending on one’s perspective, some of the advantages of Fog Computing function as disadvantages. Detriments associated with Fogs include:

Physical locality: There are some who would argue that the whole point of utilizing the Cloud is to access data and resources from anywhere, regardless of physical location. Although Fog Computing merely functions as a more selective way of ascertaining which data becomes centralized and which stays local, some perceive that the limitations of the latter are disadvantageous in terms of access.

Security: Security has long been regarded as the Achilles heel of the Cloud, but with a number of developments in this space within the past several years, issues of security really amount to a matter of trust. Certain organizations feel more comfortable having their data in a

centralized location rather in remote, disparate ones—although the former option can exacerbate Data Governance when considered on a global scale.

Confusion: There is also the perspective that facilitating Fog Computing merely adds to the number of Cloud options (public, private, hybrids, cloudlets, etc.) and is needlessly complicating architecture that is already complex enough. Conceivably, such pundits would harbor the same opinion about the IoT in general.

CONCLUSIONS

As discussed current definitions of fog computing and similar concepts, and proposed a more comprehensive definition analysed the goals and challenges in fog computing platform, and presented platform design with several exemplar applications and finally implemented and evaluated a prototype fog computing platform. Outlined the vision and defined key characteristics of Fog Computing, a platform to deliver a rich portfolio of new services and applications at the edge of the network. The motivating examples peppered throughout the discussion range from conceptual visions to existing point solution prototypes. Fog to be a unifying platform, rich enough to deliver this new breed of emerging services and enable the development of new applications. Welcome collaborations on the substantial body of work ahead: 1) Architecture of this massive infrastructure of compute, storage, and networking devices; 2) Orchestration and resource management of the Fog nodes; 3) Innovative services and applications to be supported by the Fog.

REFERENCES

1. M. D. Assunção, R. N. Calheiros, S. Bianchi, M. A. Netto, and R. Buyya, “Big data computing and clouds: Trends and future directions,” *Journal of Parallel and Distributed Computing*, 2015; 79: 3–15.
2. B. Varghese, N. Wang, S. Barbhuiya, P. Kilpatrick, and D. S. Nikolopoulos, “Challenges and Opportunities in Edge Computing,” in *IEEE International Conference on Smart Cloud*, 2016; 20–26.
3. N. Wang, B. Varghese, M. Matthaiou, and D. S. Nikolopoulos, “ENORM: A Framework for EdgeNode Resource Management,” *IEEE Transactions on Services Computing*, 2017.
4. A. V. Dastjerdi and R. Buyya, “Fog Computing: Helping the Internet of Things Realize Its Potential,” *Computer*, 2016; 49(8): 112–116.
5. <https://ieeexplore.ieee.org/document/8085127/all-figures>.

6. J. Chen, Y. Chen, X. Du, C. Li, J. Lu, S. Zhao, and X. Zhou, "Big data challenge: a data management perspective," *Frontiers of Computer Science*, 2013; 7(2): 157–164.
7. Y. Wu, H. Song, Y. Xiong, Z. Zheng, Y. Zhang, and G. Huang, "Model defined fault tolerance in cloud," in *Proceedings of the 6th Asia-Pacific Symposium on Internetware on Internetware*. ACM, 2014; 116–119.
8. I. P. Egwuotuoha, S. Chen, D. Levy, B. Selic, and R. Calvo, "Energy efficient fault tolerance for high performance computing (hpc) in the cloud," in *Cloud Computing (CLOUD), IEEE Sixth International Conference on*. IEEE, 2013; 762–769.
9. J. K. Zao, T. T. Gan, C. K. You, S. J. R. Méndez, C. E. Chung, Y. Te Wang, T. Mullen, and T. P. Jung, "Augmented brain computer interaction based on fog computing and linked data," in *Proceeding of the International Conference on Intelligent Environments (IE)*. IEEE, 2014; 374–377.
10. A. M. Rahmani, T. N. Gia, B. Negash, A. Anzanpour, I. Azimi, M. Jiang, and P. Liljeberg, "Exploiting smart e-health gateways at the edge of healthcare internet-of-things: a fog computing approach," *Future Generation Computer Systems*, 2018; 78: 641–658.
11. R. Mahmud, F. L. Koch, and R. Buyya, "Cloud-fog interoperability in iot-enabled healthcare solutions," in *Proceedings of the 19th International Conference on Distributed Computing and Networking*, ser. ICDCN '18. New York, NY, USA: ACM, 2018; 32: 1–32:10. [Online]. Available: <http://doi.acm.org/10.1145/3154273.3154347>.
12. B. Urgaonkar, G. Pacifici, P. Shenoy, M. Spreitzer, and A. Tantawi, "Analytic modeling of multitier internet applications," *ACM Transactions on the Web (TWEB)*, 2007; 1(1): 2.
13. Y. Sharma, B. Javadi, W. Si, and D. Sun, "Reliability and energy efficiency in cloud computing systems: Survey and taxonomy," *Journal of Network and Computer Applications*, 2016; 74: 66–85.
14. Y. Liu, J. E. Fieldsend, and G. Min, "A framework of fog computing: Architecture, challenges, and optimization," *IEEE Access*, 2017; 5: 25 445–25 454.
15. "Cisco fog data services," Dec 2016. [Online]. Available: <http://www.cisco.com/c/en/us/products/cloud-systemsmanagement/fog-data-services/index.html>.
16. "Cisco fog director," Jan 2017. [Online]. Available: <http://www.cisco.com/c/en/us/products/cloud-systems-management/fog-director/index.html>.
17. G. Albeanu and F. Popentiu-Vladicescu, "A reliable e-learning architecture based on fog-computing and smart devices," in *The International Scientific Conference eLearning and Software for Education, "Carol I" National Defence University*, 2014; 4: 9.