

PERFORMANCE IMPLEMENTATION OF SELF-REGULATING CONTROLLERS FOR SWITCHED RELUCTANCE MOTOR DRIVE

M. Kannan¹, S. Sujitha*², J. Saranya³ and R. Sowmiya⁴

¹Assistant Professor, EEE Department, Muthayammal College of Engineering, Rasipuram.

^{2,3,4}UG Students, EEE Department, Muthayammal College of Engineering, Rasipuram.

Article Received on 05/02/2019

Article Revised on 26/02/2019

Article Accepted on 18/03/2019

***Corresponding Author**

S. Sujitha

UG Students, EEE

Department, Muthayammal

College of Engineering,

Rasipuram.

ABSTRACT

The SRM is used in various industrial applications due to its profitable advantages. Initially PI controller used for speed control of switched reluctance motor. Then fuzzy logic and H- Infinity control methods are used for speed control of switched reluctance motor. Finally GA based H -Infinity control technique applied for speed control for switched

reluctance motor. H infinity control is an external control technique so the weight of the transfer function matrix is improved and the system is controlled perfectly by totaling the input weight noise function matrix value and weight uncertainty. The weight of the transfer function matrix is changed at every different system states. The process of finding an optimal control weight is complex because the H-Infinity control process is a closed loop control. This would be fall of control accuracy and also increases the merging time. To overcome these problems, an optimal GA based H-Infinity control concept is proposed. In the proposed control process, the optimal transfer function matrix weight is obtained by Genetic Algorithm. The proposed GA based optimal H-Infinity control method is simulated in MATLAB and also speed of the SRM is controlled by the proposed optimal GA based H -Infinity control method.

INDEXTERMS: Switched Reluctance Motor, PI control, Fuzzy logic control, H-Infinity control, Robustness and GA based H- Infinity control algorithm.

I. INTRODUCTION

The Switched Reluctance Motor is applied in various industrial applications due to its profitable advantages. But, the robustness speed of SRM is one of the major drawbacks, which greatly affects the performance of motor. Control the speed of SRM using H-infinity control strategy. This H-infinity control technique is stronger against robustness. In the proposed speed controller, the rotor position of the SR motor is applied to the controller. The speed variation of the rotor is determined from the reference speed and applied to the controller as input. Then, the speed difference and the same sensitivity function are determined. The sensitivity function prediction is based on the input side weight of the controller. The weight adjustment process is repeated until a stable speed condition is achieved. Then, the output of the proposed control technique is compared with the existing control technique and the robustness is analyzed.

In normal control technique have the uncertainties have parameters namely model error and variation outer disorder. But, the H-infinity control technique is an external control technique. The weight of the transfer function matrix is improved and the system is controlled perfectly by totaling the input weight noise function matrix value and weight uncertainty. The weight of the transfer function matrix is changed at different system state. Therefore, an optimal control weight is needed to make the system robust. The process of finding optimal control weight is complex because the H-infinity control process is a closed loop controller. This would result in fall of control accuracy and also increases the merging time. To overcome these difficulties, the optimal H-infinity control concept is proposed. In the proposed control procedure, the optimal transfer function matrix weight is obtained by genetic algorithm which is an efficient optimization algorithm. The proposed GA based optimal H-infinity control method is implemented in MATLAB. Also, the speed of the switched reluctance motor is controlled by the proposed optimal H-infinity control technique and the speed controlling concert is tested with the straight H-infinity control technique. The weight noise setting is obtained for every time instant and optimal weight noise is calculated. The optimal weight noise setting can be attained by H-infinity optimal control using GA approach

II. SRM DRIVE SYSTEM

The digital controller is connected with the converter and firing circuit, which can activate the converter of the SRM to have the control over the pulsating signals. The main function of the controller is to give the power supply to SRM. And the output voltage of the converter

and compare with the reference voltage to produce the actuating signal to have the error signal which will compensate with the set voltage, thus the SRM will now be applied the rated voltage. Converter gets activated by the windings of the SRM. The torque production in SRM is explained using the elementary principle of electromechanical energy conversion in a solenoid. Figure 1 shows the digital controller based SRM Speed control. Digital Controller such as H – Infinity controller and GA based Controller.

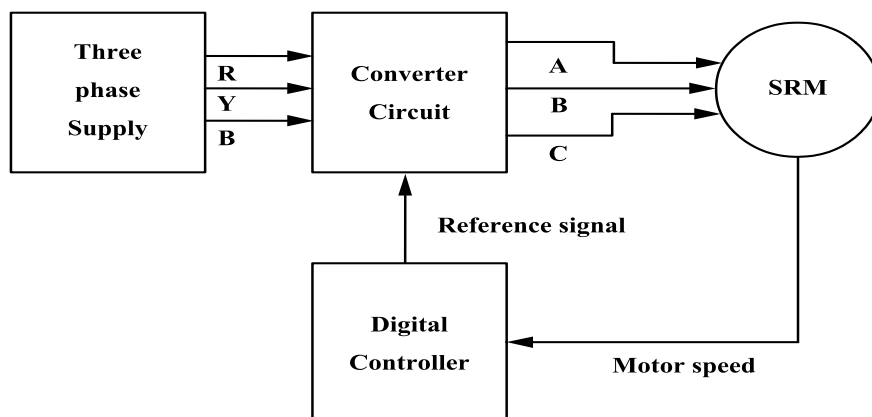


Figure 1: Block diagram of Switched Reluctance Motor.

Digital controller used for corrects the error and improve the performance of SRM. Depending upon the error signal, digital controller fed the signal to converter circuit and activates the SRM phase winding. Speed of SRM maintained constant by digital controller

II. PI CONTROL TECHNIQUE FOR SRM

Proportional-Integral (PI) controllers are widely used in Switched reluctance motor drive for accurate speed control and better speed holding capacity. The combination of proportional and integral increases the speed of the response and reduces the steady state error. The PI controller is widely used in industry as it is a simple and effective controller for applications that do not require a more sophisticated approach. For the speed control of this SRM, the PI controller has been deemed adequate for a variable speed SRM not requiring servo like control. Figure 2 shows the PI controller based switched reluctance motor drive. SRM current controller sees a nonlinear plant with varying plant gain even within normal operating condition. Additionally, the current reference is time-varying. As expected and verified experimentally, integral (I) control is not effective in case of a finite-time tracking problem. The controller gains had been increased to reduce the tracking error in the rising and falling portions of the current reference. This had resulted in oscillations in current for constant part

of current reference. This establishes that constant gain PI current controller is not suitable for high performance current controller in SRM.

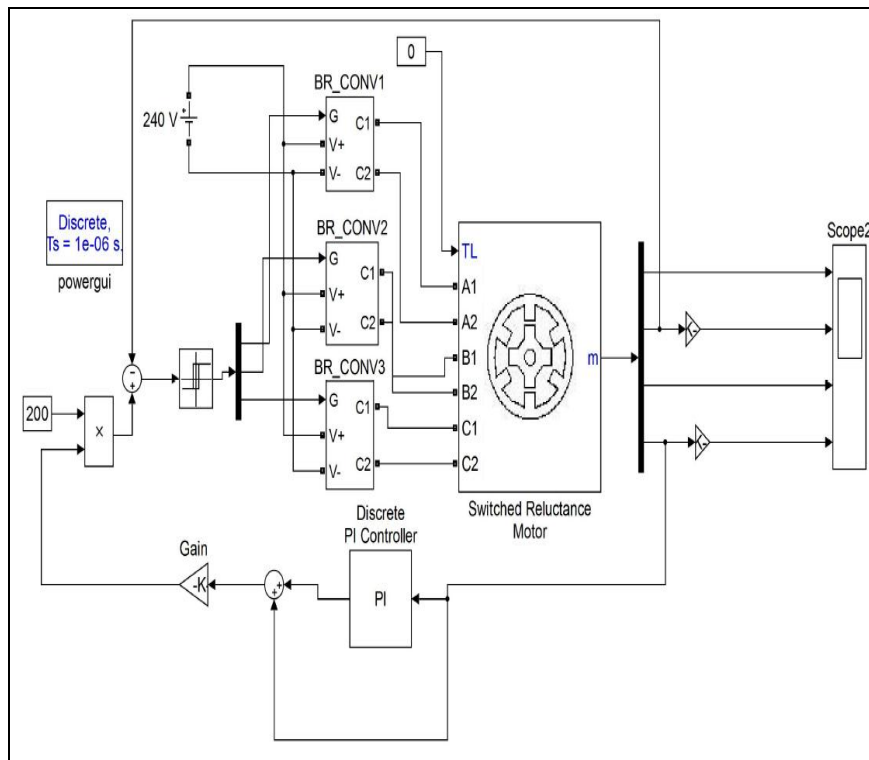


Figure 2: Simulation diagram of PI controller based SRM Drive system.

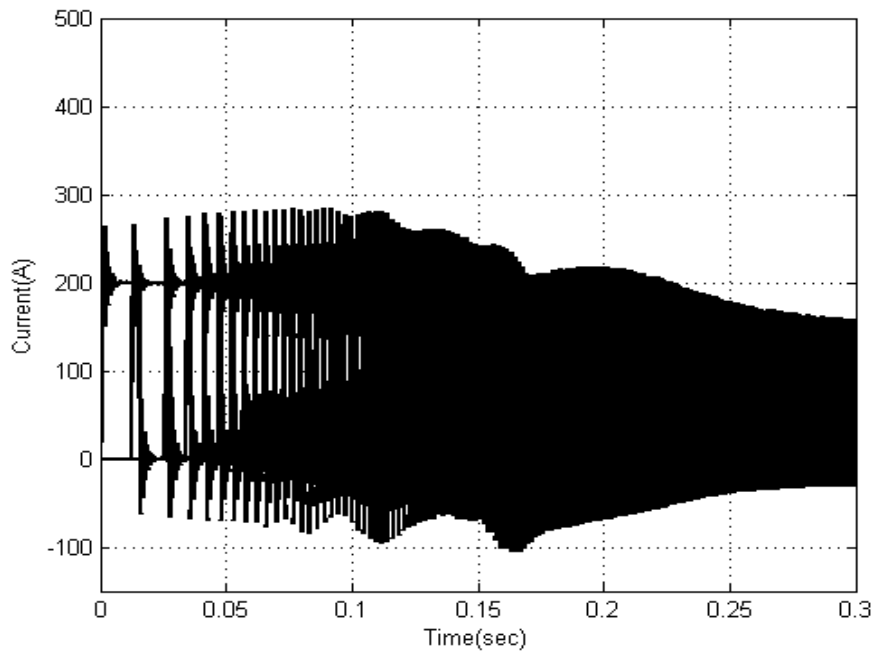


Figure 3: SRM Current of PI controller.

Figure 3 shows the SRM torque of PI controller. Initially Motor starting torque 165Nm and finally settled the motor torque value of 75Nm.

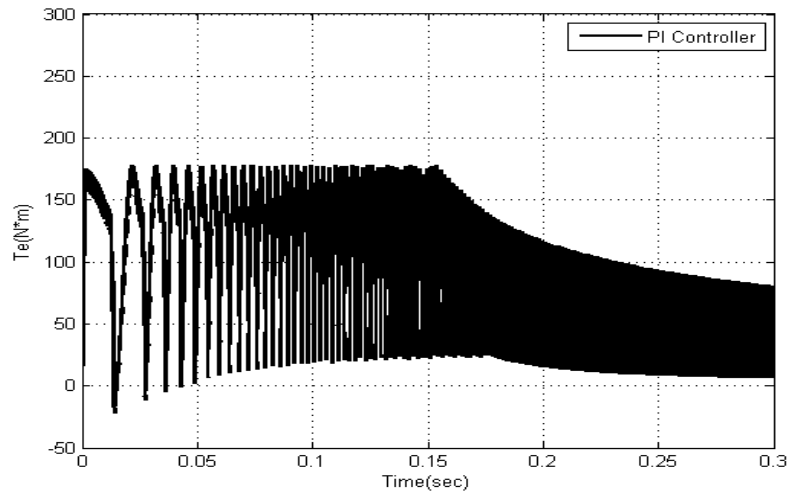


Figure 4: SRM Torque of PI controller.

Figure 4 shows the SRM speed of PI controller. Starting speed of SRM rapidly increase to 8200 rpm and after 0.28 sec SRM maintain the speed around 4500rpm.

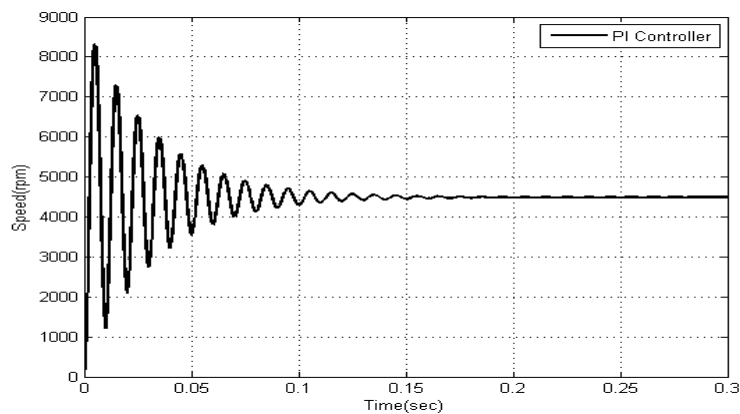


Figure 5: SRM Speed of PI controllers.

III Fuzzy Logic Controller for Srm

Figure 6 shows the Mamdani fuzzy logic controller based SRM. Fuzzy logic controller block inserted the SRM Simulink mode. The main function of the FLC is to take the output voltage of the converter and compared with the reference voltage to produce the actuating signal which will compensate with the set voltage, thus the SRM will now be supplied with rated voltage. Converter gets activated the windings of the Switched reluctance motor. The torque production in the switched reluctance motor is explained using the elementary principle of

electromechanical energy conversion in a solenoid. The fuzzy logic controller is implemented in the SRM drive system. FLC is used in closed loop control and better performance of reduced harmonics and accurate speed regulation as that of the set speed is obtained

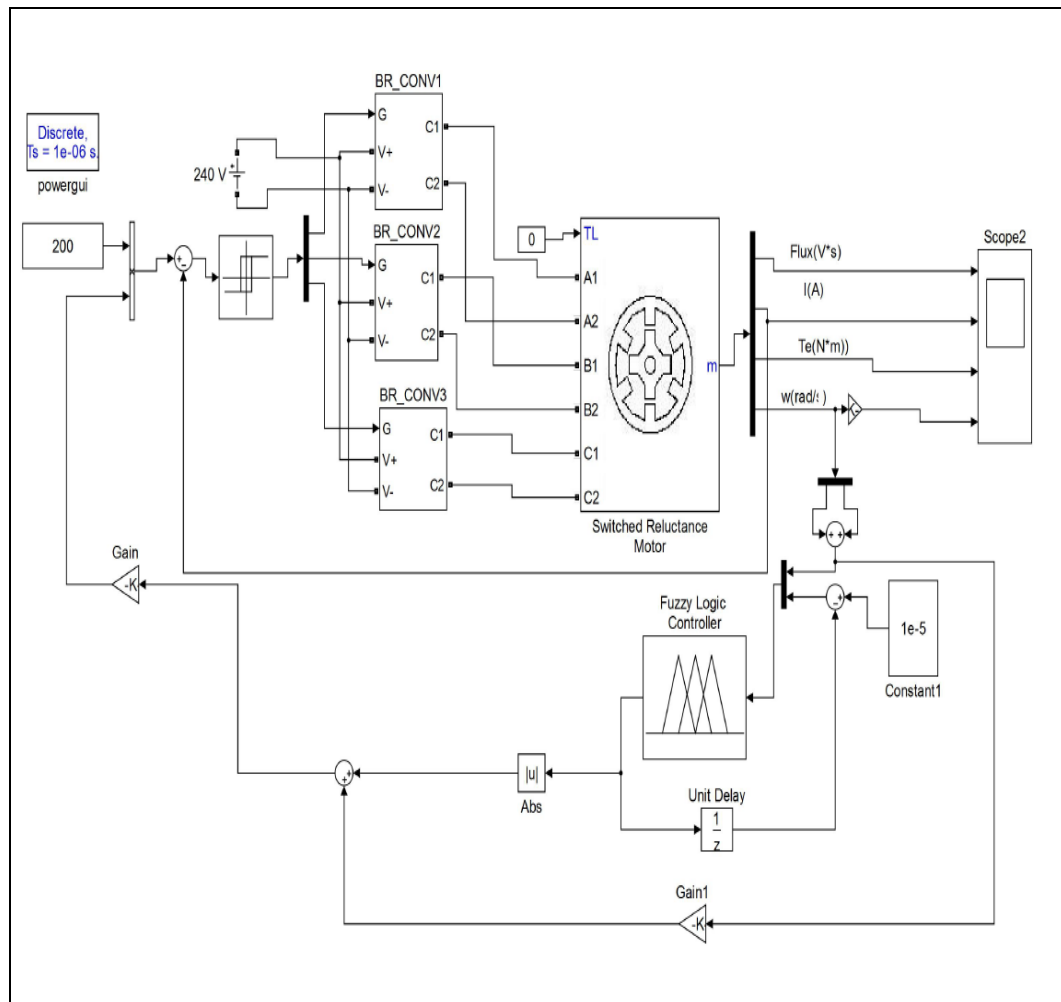


Figure 6: Mamdani fuzzy controller based SRM Control Model.

A. Fuzzy Rules Description

Fuzzy rules for the FLC to control the error in speed can be given as follows: there are nine rules are used for fuzzy logic controller based SRM drive.

Figure 6 shows the implementation of fuzzy logic controller based on SRM drive system. FLC is robust to load disturbance or sudden change in reference speed. It has got significant steady state error as compared with that for conventional proportional integral controller. Hence an implementation of a hybrid controller is necessary to overcome with the drawbacks existing in the FLC.

Table 1: Fuzzy rule set.

$E \backslash \Delta E$	L	M	H	L	M	H	L	M	H
L	L	L	H	L	L	H	L	L	H
L	L	L	H	L	L	H	L	L	H
L	L	L	H	L	L	H	L	L	H
M	L	M	H	L	M	H	L	M	H
M	L	M	H	L	M	H	L	M	H
M	L	M	H	L	M	H	L	M	H
H	L	M	H	L	M	H	L	M	H
H	L	M	H	L	M	H	L	M	H
H	L	M	H	L	M	H	L	M	H

B.Simulation Results of Fuzzy Logic Controller for SRM Figure 7 shows the SRM Torque performance under FLC. Initially stating torque value of 155Nm and torque settled at 75Nm.

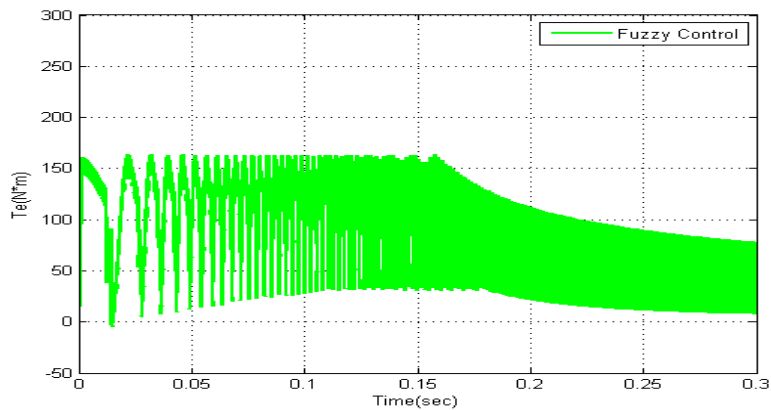
**Figure 7: SRM Torque performances under FLC.**

Figure 8 shows the SRM current of Fuzzy logic controller. Initially stating current nearly 200A and finally settled at 98A.

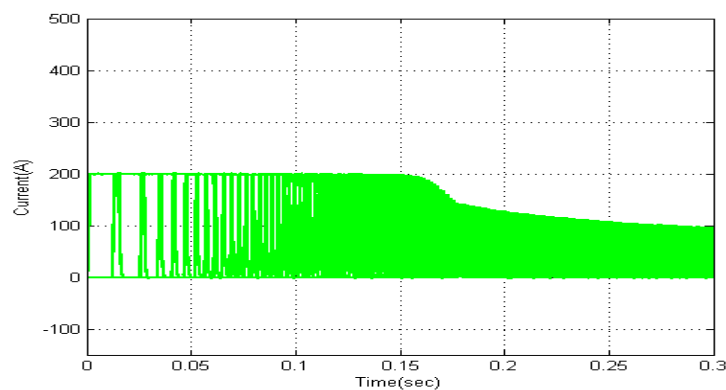
**Figure 8: SRM Current under FLC.**

Figure 9 shows the SRM Speed of Fuzzy logic controller. Initially starting Speed of 6900rpm and after 0.05sec finally speed is settled at 4500 rpm. The PI-controller takes decision during steady state to reduce steady state error of the system and the fuzzy logic controller takes decision during transient state to get fast response and low overshoot when the absolute value of speed error is greater than 7 rpm. This set value depends upon the fuzzy logic controller and the sampling frequency of for the case of steady state, the PI-controller dominates the control output to significantly reduce steady state error of the system and the FLC contributes to the output to provide fast response and low overshoot when the absolute value of speed error is higher than 7 rpm.

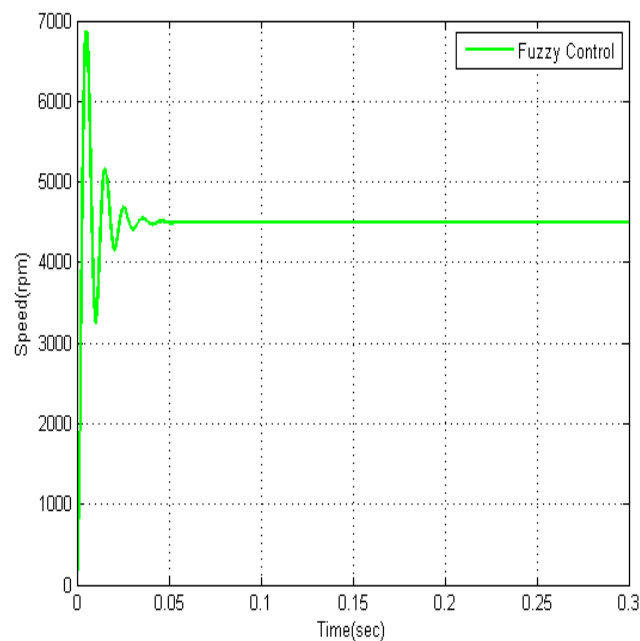


Figure 9: FLC based SRM Speed.

IV. SIMULATION AND RESULTS

The proposed H-infinity robust controller based SRM rotor position speed control technique is simulated in matlab working platform (version 7.12). From the simulated model, the rotor speed control performance of the proposed control technique is analyzed. Then, the speed control characteristics of the H-infinity control technique are compared with the existing speed control technique such as PI controller and fuzzy controller. After that, the torque, flux, and transfer function of the SR motor are described. The simulink model of the proposed control system is illustrated in Figure 13.

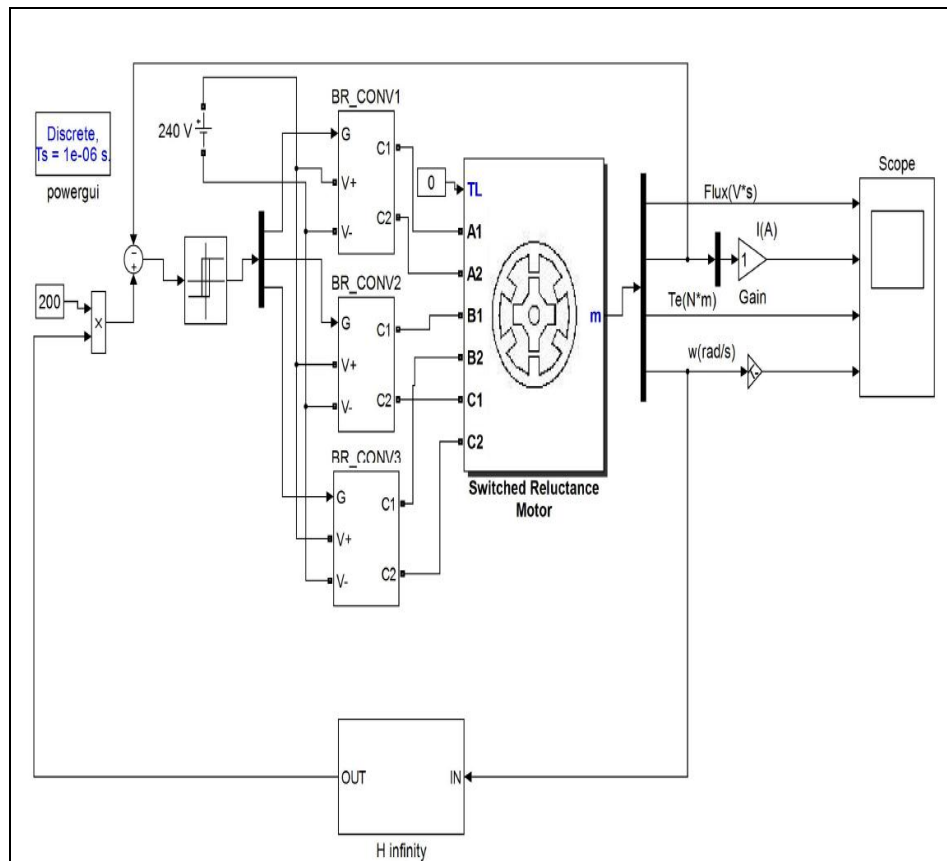


Figure 13: Simulink Model of the H-Infinity Controller.

Figure 14 shows the Speed Control of H - Infinity controller for SRM. Initially speed is increased from 0 to 4500rpm at small time interval. After 0.04 sec SRM maintained the constant Speed of 4500 rpm.

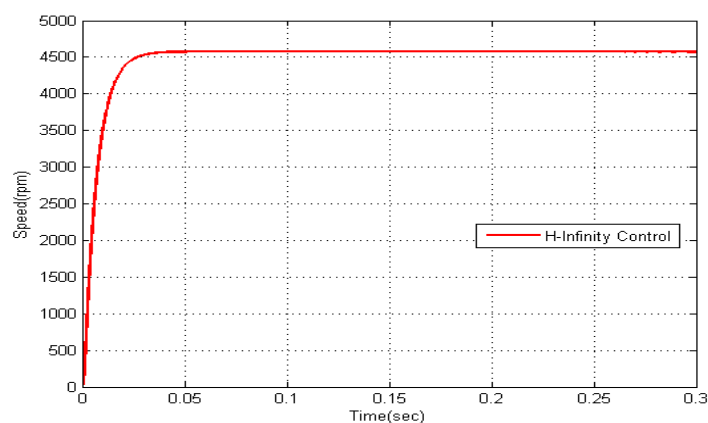


Figure 14: Rotor Speed control of H-infinity control.

Figure 15 shows the SRM current of H- Infinity controller. Initially starting flux nearly 0.4 Wb and finally settled at 0.25Wb.

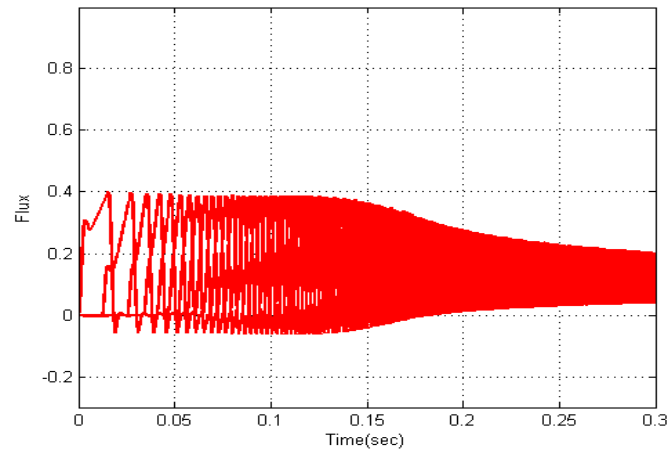


Figure 15: SRM Flux variation of H-infinity control.

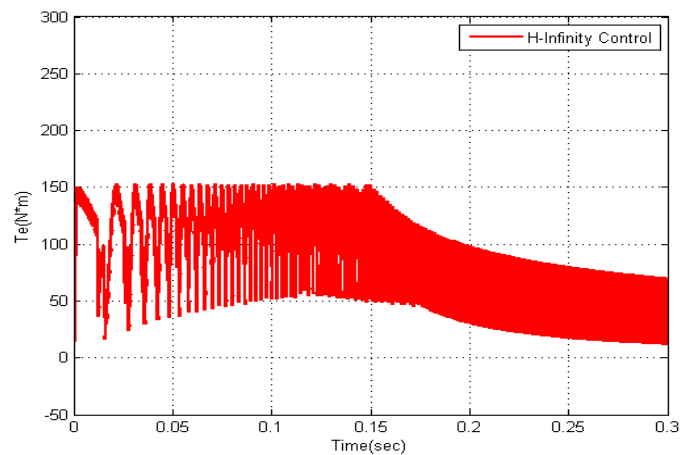


Figure 16: SRM torque of H-Infinity control.

Figure 17 shows the SRM current of H-Infinity controller. Initially starting current nearly 250A and finally settled at 75A.

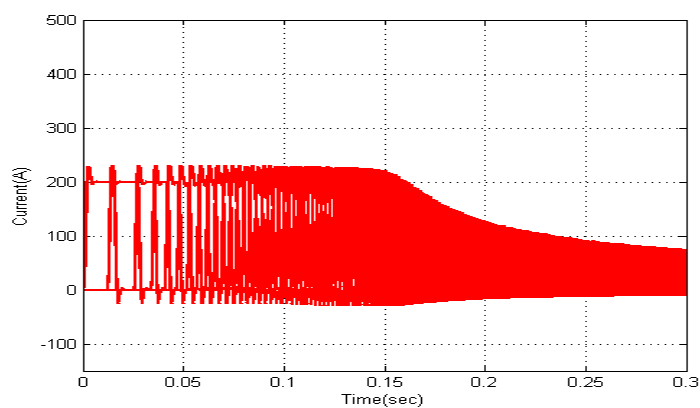


Figure 17: SRM current of H-Infinity control.

V. CONCLUSION

The PI controller, Fuzzy logic controller, H infinity controller and proposed GA based H infinity controller based Switched reluctance motor performance. Overall performance of the Proposed method more suitable for reducing robustness of SRM and improve the Speed control operation of the Switched reluctance motor. Corporately proposed GA Based H – Infinity controller based SRM shown better performance than other controllers. GA based H infinity controller based SRM consumes less current value compared with other controllers. GA based H- Infinity controlled SRM achieved low starting time, minimum torque ripple, minimum starting current, overshoot free speed and reduced speed oscillation. So efficiency of the GA based H- Infinity controlled SRM is high. Overall, the proposed H- Infinity control technique using GA has achieved a remarkable level in controlling the rotor speed and smooth speed variation of SRM motor.

REFERENCES

1. Ahmed Tahour, Abdelkader Meroufel, HamzaAbid & Abdel GhaniAissaoui, ‘Sliding Controller of Switched Reluctance Motor’, Leonardo Electronic Journal of Practices and Technologies, 2008; 12: 151-162.
2. C.Nagarajan and M.Madheswaran, ‘Experimental verification and stability state space analysis of CLL-T Series Parallel Resonant Converter with fuzzy controller’ - *Journal of Electrical Engineering*, 2012; 63(6): 365-372.
3. R.Raja and C.Nagarajan, “Performance Analysis of LCL-T Filter Based 2 Stage Single Phase Gird Connected Module with ANN Controller using PV Panel,” *Current Signal Transduction Therapy*, 2018; 13(2): 159-167.
4. C.Nagarajan and M.Madheswaran, “Performance Analysis of LCL-T Resonant Converter with Fuzzy/PID Using State Space Analysis” *Springer, Electrical Engineering*, 2011; 93(3): 167-178.
5. E.Geetha, C. Nagarajan, “Stochastic Rule Control Algorithm Based Enlistment of Induction Motor Parameters Monitoring in IoT Applications,” *Wireless Personal Communications*, 2018; 102(4): 3629–3645.
6. M.Madheswaran, C.Nagarajan, “DSP Based Fuzzy Controller for Series Parallel Resonant converter”, *Frontiers of Electrical and Electronic Engineering*, 2012; 7(4): 438-446.
7. C.Nagarajan, “Single-Stage High-Frequency Resonantac/AC Converter Using Fuzzy Logic and Artificial Neural networks’, *Conference on Emerging Devices and Smart*

- Systems (ICEDSS), 2nd and 3rd March*, organized by mahendra Engineering College, Mallasamudram, 2018; 30-37.
8. E Geetha, C Nagarajan, "Induction Motor Fault Detection and Classification Using Current Signature Analysis Technique", *Conference on Emerging Devices and Smart Systems (ICEDSS), 2nd and 3rd March*, organized by mahendra Engineering College, Mallasamudram, 2018; 48-52.
 9. GS SatheeshKumar, C Nagarajan, ST Selvi, "A Virtual Impedance Based Analysis of Dynamic Stability in a Micro-Grid System", *Conference on Emerging Devices and Smart Systems (ICEDSS), 2nd and 3rd March*, organized by mahendra Engineering College, Mallasamudram, 2018; 38-41.
 10. CS Lakshmi, C Nagarajan, "Neural Controlled Multi-Level Inverter Based DVR for Power Quality Improvement", *Conference on Emerging Devices and Smart Systems (ICEDSS), 2nd and 3rd March*, organized by mahendra Engineering College, Mallasamudram, 2018; 42-47.
 11. S Thirunavukkarasu, C Nagarajan, "Performance Analysis of BLDC Motor Drive for Feed Drives", *Conference on Emerging Devices and Smart Systems (ICEDSS), 2nd and 3rd March*, organized by mahendra Engineering College, Mallasamudram, 2018; 67-70.
 12. JP Daniel, C Nagarajan, "Hybrid Filter for Distorted Voltage Source in Microgrids", *Conference on Emerging Devices and Smart Systems (ICEDSS), 2nd and 3rd March*, organized by mahendra Engineering College, Mallasamudram, 2018; 11-15.
 13. K Umadevi, C Nagarajan, "High Gain Ratio Boost-Fly Back DC-DC Converter using Capacitor Coupling", *Conference on Emerging Devices and Smart Systems (ICEDSS), 2nd and 3rd March*, organized by mahendra Engineering College, Mallasamudram, 2018; 64-66.
 14. C.Nagarajan and M.Madheswaran, "Experimental Study and steady state stability analysis of CLL-T Series Parallel Resonant Converter with Fuzzy controller using State Space Analysis", *Iranian Journal of Electrical and Electronic Engineering*, 2012; 8(3): 259-267.
 15. C. Santhana Lakshmi and C. Nagarajan, "Multiconverter Technology Based Voltage Compensation for Photovoltaic System" *Ecology, Environment and Conservation*, 2017; 23: 226-229.
 16. C.Nagarajan and M.Madheswaran, "Stability Analysis of Series Parallel Resonant Converter with Fuzzy Logic Controller Using State Space Techniques", *Electric Power Components and Systems*, 2011; 39(8): 780-793.

17. C.Nagarajan, M.Muruganandam and D.Ramasubramanian – ‘Analysis and Design of CLL Resonant Converter for Solar Panel - Battery systems- *International Journal of Intelligent systems and Applications*, 2013; 5(1): 52-58.
18. C.Nagarajan and M.Madheswaran, “Experimental Study and Comparative Analysis of CLL-T and LCL-T Series Parallel Resonant Converter with Fuzzy/ PID Controller”, *Journal of Electrical Engineering*, 2011; 11(3): 122-129.
19. C.Nagarajan and M.Madheswaran, “Analysis and Simulation of LCL Series Resonant Full Bridge Converter Using PWM Technique with Load Independent Operation” has been presented in ICTES’08, a IEEE / IET International Conference organized by M.G.R. University, Chennai, 2007; 1: 190-195.
20. C. Nagarajan, M.Madheswaran and D.Ramasubramanian, “Development of DSP based Robust Control Method for General Resonant Converter Topologies using Transfer Function Model,” *Acta Electrotechnica et Informatica Journal*, 2013; 13(2): 18-31.
21. S.Sathish Kumar and C.Nagarajan, “Performance - Economic and Energy Loss analysis of 80 KWp Grid Connected Roof Top Transformer less Photovoltaic power Plant,” *Circuits and Systems*, 2016; 7(6): 662-679.