

HYBRID ALGORITHM FOR OPTIMIZING PEAK TO AVERAGE POWER RATIO PERFORMANCE IN MIMO-OFDM SYSTEM

¹*Agwah B. C., ²Nwabueze C. A. and ²Akaneme S. A.

¹*Department of Electrical and Electronic Engineering, Federal Polytechnic Nekede, Owerri, Nigeria.

²Department of Electrical and Electronic Engineering, Chukwuemeka Odumegwu Ojukwu University, Uli, Nigeria.

Article Received on 21/04/2020

Article Revised on 11/05/2020

Article Accepted on 01/06/2020

***Corresponding Author**

Agwah B. C.

Department of Electrical
and Electronic Engineering,
Federal Polytechnic
Nekede, Owerri, Nigeria.

ABSTRACT

This paper has examined the optimization of PAPR in Multiple-Input Multiple-Output (MIMO) -Orthogonal Frequency Division Multiplexing (OFDM) LTE network using hybrid technique. With many different PAPR reduction techniques available and each seems to outperform one another, a hybrid technique that uses precoded OFDM

signal with repeated clipping and frequency domain filtering (RCF) and Mu-law companding was proposed for reducing PAPR of OFDM signal and with less computational cost in LTE network. The concept of PAPR in OFDM was initially examined and a conventional model of OFDM system introduced. This was followed by precoded OFDM signal model. Subsequently, different OFDM system models using RCF and Mu-law algorithms were presented. A hybrid algorithm for PAPR reduction was eventually developed combining RCF and Mu-law companding using precoded OFDM signal. Simulations were carried out for LTE network considering 256 data points with QPSK modulation scheme. Also, for optimal performance, RCF algorithm was studied by selecting a clipping ratio (CR) of 3 with four iteration process (clipping and filtering, CF1, CF2, CF3, CF4), oversampling factor of 4, and the Mu value of the Mu-law companding set at 100. Simulation was initially conducted for the conventional OFDM system model when there was no algorithm included to reduce the effect of PAPR and the value of PAPR obtained was 10.51 dB. With the PAPR of the conventional OFDM signal taken as reference value to be reduced, simulations were then

carried out considering when RCF was incorporated with the conventional OFDM signal and precoded OFDM signal respectively. Results showed that with RCF and conventional OFDM, the overall reduction of PAPR was 5.739 dB representing 45.39% improvement whereas with precoded OFDM signal, the PAPR was reduced to 5.58 dB that is an improvement of 46.91%. Also, simulation was conducted with Mu-law companding and conventional OFDM signal. The result revealed that PAPR was reduced to 3.267 dB which represents 68.92% improvement in PAPR value. Finally, simulation test was carried out for the proposed hybrid system and the result obtained shows that the OFDM was significantly reduced to 1.757 dB which was 83.28% improvement in PAPR value. Thus, the proposed hybrid technique have shown capacity to largely and optimally reduce the PAPR of OFDM signal and as such is a promising scheme for addressing PAPR problem in MIMO-OFDM systems.

KEYWORDS: Hybrid Technique, LTE Network, MIMO-OFDM, PAPR.

1. INTRODUCTION

The integration of Orthogonal Frequency Division Multiplexing (OFDM) with Multi Input Multi Output (MIMO) as a technique in wireless mobile communication systems offers a possible alternative for improving the Quality of Service (QoS) and at the same time achieves high spectral efficiency and data rate. Nevertheless, the high peak-to-average power ratio (PAPR) is the principal concern that should be considered in the MIMO-OFDM system. High PAPR is an effect which is caused in OFDM systems due to the use of large number of sub-carriers (or sub-blocks). This reduces the operation of transmitter power amplifier and causes receiver amplifier saturation. In order to take care of this problem, several other techniques such as clipping, clipping and filtering, coding, tone injection, peak windowing, selected mapping, and partial transmit sequence (PTS) have been presented to reduce the high PAPR of MIMO-OFDM signals. Each of these techniques has its merits and demerits. However, combining two or more techniques can be promising. The combination will exploit the merits of the different techniques while at the same time compensating for their weakness.

It should be noted that despite the advantages offer by MIMO-OFDM technology, it still suffers from the high fluctuations of the transmitted signal called the peak-to-average power ratio (PAPR). In order to deal with this problem, several techniques such as precoding, clipping and Filtering, coding, tone injection, peak windowing, selected mapping, and partial transmit sequence (PTS), and companding have been proposed to mitigate the high PAPR of

OFDM signals. All these methods have their own advantages and disadvantages, however using a technique (hybrid) that exploits the benefits offer by these techniques while compensating for their weaknesses will be worthwhile.

Some techniques to improve on exiting scheme using genetic algorithm and hybrid combination of two or more schemes have been proposed recently by different researchers. Reduced computational complexity Partial Transmit Sequence (PTS) technique based on firework algorithm (FWA) was proposed by Amhaimar et al (2018) and was tested on IEEE 802.11a and 802.16e standards with results obtained outperforming other well-known evolutionary algorithms such simulated annealing (SA), particle swarm optimization (PSO), and genetic algorithm (GA). A technique that combines tone reservation (TR) techniques and phase information of the pilot tones for PAPR reduction such that by combining the dummy symbols and pilot phase information the PAPR of the MIMO-OFDM signals can be effectively reduced was proposed by Manasseh et al. (2011). The fact that the amplitudes of PAPR signals are nonlinearly and non-monotonically increasing was exploited by Anoh et al. (2017) to develop a root-based nonlinear companding scheme for the reduction of PAPR in precoded OFDM signals. A variation of repeated clipping and filtering (RCF) and tone reservation/injection techniques for PAPR reduction was carried out by Singh et al (2013) and being aware of the possibility of the peak of the time-domain signal re-growing, after the filtering operation, recursive clipping and filtering (RCF) was used to curb both the out-of-band energy and the PAPR. Using repeated clipping and filtering (RCF) and selective mapping (SLM) techniques, Manjula and Muralidhara (2017) were able to reduce the PAPR to significant level in OFDM system. A combination of precoding with repeated clipping and filtering (RCF) was used by Dubey and Gupta (2016) to carry out PAPR reduction of OFDM signal. Six precoding matrices namely Walsh-Hadamard Transform (WHT), Discrete Cosine Transform (DCT), Zadoff-Chu Matrix Transform (ZCT), Discrete Hartley Transform (DHT), Discrete Fourier Transform (DFT), and Square-root Raised Cosine (SRC), found in the literature were examined by Mounir et al. (2018) for PAPR reduction in OFDM system. All precoding matrices, except the one which is based on square-root raised cosine function (SRC), were not effective in terms of BER performance in presence of nonlinear power amplifier (PA), especially in high modulation order schemes such as 6-QAM and 64-QAM. ZCT and DFT precoding matrices were found to have the best PAPR reduction gain among the six ($N \times N$) predefined matrices. Repeated frequency domain filtering and clipping (RFC) was proposed by Devi and Ramprabhu (2018) to reduce PAPR of OFDM signal. Reduction

of PAPR by using amplitude clipping and filtering was in LTE downlink system was proposed by Haque and Mowla (2015). Infinite Impulse Response (IIR) band pass elliptic filter was used after amplitude clipping to reduce the PAPR.

The study so far shows that the issue of peak-to-average-power ratio (PAPR) is a major challenge in MIMO-OFDM networks. Many approaches and intelligent algorithms have been proposed by various researchers to decrease PAPR and yet improvement in terms of reduced computational complexity occasioned by increase in number of sub-carriers (or sub-blocks) is required.

The survey of literature revealed that recent approaches to PAPR tend towards the use of hybrid schemes so as to explore the advantages offered by individual technique while compensating for their weaknesses. Considering the studies carried out by Anoh *et al.* (2017), Dubey and Gupta (2016), Mounir *et al.* (2018) and Devi and Ramprabhu (2018), it was observed that the results obtained were promising. Anoh *et al.* (2017) used precoding and Mu-law companding, Dubey and Gupta (2016) used precoding and RCF, Mounir *et al.* (2018) used precoding only, while Devi and Ramprabhu (2018) used RCF only. Thus it becomes necessary to combine the various algorithms such as precoding, repeated clipping and filtering, and Mu-law companding so as to have a more robust and improved hybrid system that will further reduced PAPR in OFDM signal. In this paper, a hybrid technique that uses precoded OFDM signal with repeated clipping and frequency domain filtering (RCF) and Mu-law companding is proposed for reducing PAPR of OFDM signal and with less computational cost in LTE network.

The objective of this paper is to optimize peak to average power ratio (PARR) in MIMO-OFDM LTE network using hybrid algorithm.

2. MATERIALS AND METHODS

In this paper the main material used for the purpose of implementation and analysis is MATLAB. Other parts of this section deals with the method used.

2.1 PAPR Problem in MIMO-OFDM System

The output waveform of an OFDM system is usually associated with large fluctuations compared to conventional Single Carrier (SC) systems. It therefore means that devices of the system, like power amplifiers, Analogue-to-Digital (A/D) converters, and Digital-to-

Analogue (D/A) converters, are to have high linear dynamic ranges. Otherwise, a series interference which is not desirable occurs at any time the amplitude (or peak) signal is driven into the nonlinear region of the devices at the transmit end. The result in this case is high out of band radiation and inter-modulation distortion (Yi and Iinfeng, 2009). Hence, a technique for reducing PAPR is of great importance for OFDM system.

MIMO-OFDM is a generalized case of OFDM systems based on space time block code (STBC) (Alamouti and Patole, 1998; Tarokh et al, 1999; Amhaimar et al, 2018) for two, three, and four antennas. The encoder signal with two transmitting antennas, using Alamouti code and an input signal $X = [X(0), X(1), \dots, X(N-1)]$ is given as:

$$\begin{aligned} X_1 &= [X(0), -X^*(1), \dots, X(N-1), -X^*(N-1)]^T \\ X_2 &= [X(1), X^*(0), \dots, X(N-1), -X^*(N-2)]^T \end{aligned} \quad (1)$$

Where N is the number of independent modulated and orthogonal subcarriers whose peak (or PAPR) values are large. The signals X_1 and X_2 are transmitted by antennas 1 and 2, respectively.

At each antenna of MIMO-OFDM system, the peak-to-average power ratio (PAPR) is given by:

$$\text{PAPR}\{x_i\} = \frac{\max\{|x_i(n)|^2\}}{E\{|x_i(n)|^2\}}, \quad 0 \leq n \leq LN-1, \quad (2)$$

Where $i = 1, 2, \dots, N_T$ number of transmit antennas and L is the oversampling factor (OF). The time domain signal at each transmit antennas can be presented by:

$$x_i(n) = \frac{1}{\sqrt{N}} \sum_{k=0}^{N-1} X_k^i e^{(j2\pi nk/LN)} \quad (3)$$

The expression that characterizes the peak power variation of MIMO-OFDM systems is defined as:

$$\text{PAPR}_{\text{MIMO-OFDM}} = \max\{\text{PAPR}(x_i)\}, \quad i = 1, \dots, N_T \quad (4)$$

2.2 Probability Distribution Function of PAPR

Using central limit theorem, given a large number of subcarriers in multicarrier signal, the real and imaginary part of sample values in time domain will conform to Gaussian

distribution with mean and variance values of 0 and 0.5 respectively. Thus, the amplitude of multicarrier signals follows Rayleigh distribution with zero mean and a variance of N times the variance of one complex sinusoid (Jankiraman, 2004). The multicarrier signal power value obeys a χ^2 distribution with mean of zero and two degree of freedom (2DOF) (Yi and Linfeng, 2009). The expression for the Cumulative Distribution Function (CDF) is given by:

$$F(Z) = 1 - \exp(-Z) \quad (5)$$

Where Z is the independently and identically distributed Rayleigh random variables and $F(Z)$ is the probability density function of Z .

If the sampling values of different sub-channels are assumed to be mutually independent, and that are free of oversampling operation, the Probability Distribution Function (PDF) for PAPR less than a certain threshold value is given by:

$$P(\text{PAPR} < Z) = F(Z)^N = (1 - \exp(-Z))^N \quad (6)$$

However, the probability of PAPR exceeding a threshold as measurement index is preferably used in practice to represent the distribution of PAPR. This probability can be defined as Complementary Cumulative Distribution Function (CCDF), and it is mathematically given by:

$$P(\text{PAPR} > Z) = 1 - P(\text{PAPR} \leq Z) = 1 - F(z)^N = 1 - (1 - \exp(-Z))^N \quad (7)$$

The theoretical PAPR's of CCDF distribution can be obtained with different number of subcarriers that is, $N = 16, 32, 64, 128, 256, 512, 1024$.

2.3 Proposed Hybrid Technique

Some studies in literature have implemented hybrid techniques besides the various PAPR reduction methods. In this paper, a hybrid method with more than two techniques is proposed for PAPR reduction. A three algorithm (hybrid) method was chosen in this paper to optimize PAPR performance in MIMO-OFDM because it is believed to exploit the various advantages of each of the technique to overcome their separate weaknesses. Figure 1 shows the proposed OFDM system model with the three algorithms namely, precoding, repeated clipping and frequency domain filtering (RFC) and the mu-law. The first algorithm to act on the OFDM signal is the precoding, after which the information is passed on to the RFC algorithm, and eventually to the mu-law companding algorithm. The analysis of the performance of the system is on its effectiveness in reducing PAPR. Since this effect is

peculiar to the transmit end of OFDM system, analysis will be considered at the transmit level.

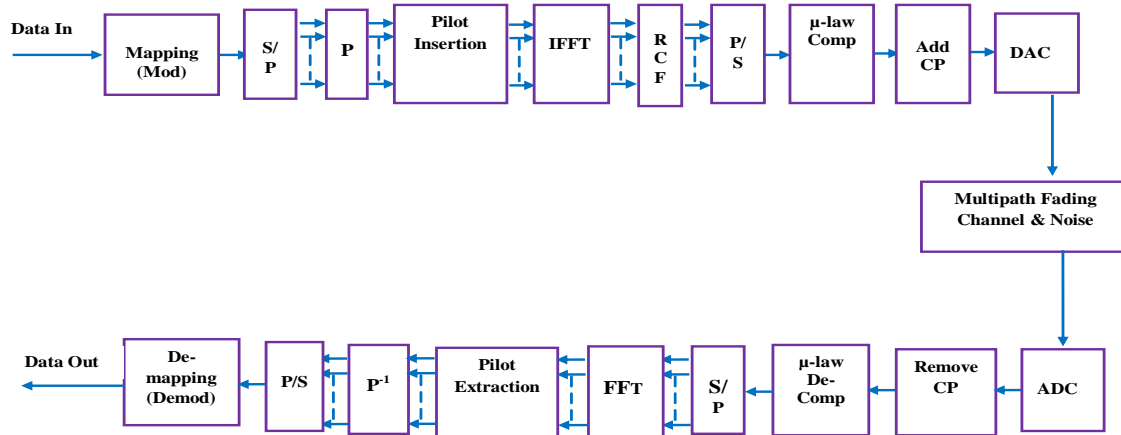

Fig. 1: Proposed OFDM system model for PAPR reduction.

The various algorithms that are utilized in the proposed model and the block diagrams of their combinations with conventional OFDM system model are discussed as follows

2.3. 1 Addition of Precoder in OFDM System

In this work, a precoder is added to the conventional OFDM system model as shown in Fig. 1. A precoder carries out a precoding function. Precoding is a pre-distortion technique. In pre-distortion technique, the concept is based on the re-orientation or spreading the energy of data symbol before carrying out IDFT or IFFT. The proposed system uses Discrete Fourier Transform (DFT) precoding scheme that is used as a “spreading” code and has the same size as IDFT. Therefore, the OFDM systems happen to be equivalent to the Single Carrier (SC) system due to the fact that the DFT and IDFT operations virtually eliminate each other (Aboul-Dahab et al., 2013; Galda and Rohling, 2002). This way, the PAPR of the transmitted signal will be the same as that of a SC system, which invariably leads to PAPR improvement. The precoding matrix P of dimension N×N implemented before IFFT operation is given by Equation (3.13) (Dubey and Gupta, 2016; Aboul-Dahab et al., 2013).

$$P = \begin{bmatrix} P_{00} & P_{01} & \dots & P_{0(N-1)} \\ P_{10} & P_{11} & \dots & P_{1(N-1)} \\ \vdots & \vdots & \ddots & \vdots \\ P_{(N-1)0} & P_{(N-1)1} & \dots & P_{(N-1)(N-1)} \end{bmatrix} \tag{8}$$

The addition of the P matrix to the OFDM system will result to the complex band OFDM signal with N subcarriers given by:

$$x(t) = \sqrt{\frac{1}{N}} \times \sum_{k=0}^{N-1} P \cdot X_k e^{j2\pi k \Delta f t} \quad 0 \leq t \leq NT \quad (9)$$

Where Δf is the subcarrier spacing and NT is the useful block period.

The modulated OFDM vector signal with N subcarriers can be expressed given by:

$$x_N = \text{IFFT}\{P \cdot X_N\} \quad (10)$$

The PAPR of OFDM signal in can be expressed given by:

$$\text{PAPR} = \frac{\max |x(t)|^2}{E[|x(t)|^2]} \quad (11)$$

The DFT of a sequence of length N and IDFT can be expressed given by (Aboul-Dahab et al., 2013):

$$X(k) = \sum_{n=0}^{N-1} x(n) e^{-j2\pi nk}, \quad k = 0, 1, \dots, N-1 \quad (12)$$

$$x(n) = \frac{1}{N} \sum_{k=0}^{N-1} X(k) e^{j2\pi nk}, \quad k = 0, 1, \dots, N-1 \quad (13)$$

Where, $p_{mn} = e^{-j2\pi mn/N}$, m and n are integers from 0 to $N-1$.

2.3.2 Repeated Clipping and Frequency Domain Filtering

The Repeated Clipping and Frequency Domain Filtering simply referred to as Repeat Clipping and Filtering (RCF) is a signal distortion based scheme. In this technique, the input vector $S_i = s_0, s_1, s_2, \dots, s_{N-1}$ is first transformed using an oversized IFFT, where N is the number of subcarriers in each OFDM symbol. For every L time oversampling, the input vector S_i is extended by adding $N(1-1)$ zeros in the middle of the input vector. This leads to trigonometric interpolation of time domain signal. A perfect interpolation is offered by trigonometric interpolation when the original signal comprises integral frequencies over the FFT window. This is the associated with OFDM. After which the interpolated signal is clipped.

With IFFT operation done, the original signal is clipped in the time domain (Devi and Ramprabhu, 2018). The clipping can be described by:

$$C = \begin{cases} \sqrt{CR * E[|x|^2]} * \frac{x}{|x|} & |x|^2 > C_m \\ x & |x|^2 \leq C_m \end{cases} \quad (14)$$

Where C represents the time domain signal of the output, $|x|^2$ is the signal absolute power, $E[|x|^2]$ is the mean signal power, CR is the clipping ratio, which is defined as the ratio of the clipping level to the mean power of the unclipped baseband signal, and C_m is the threshold clipping level given by:

$$C_m = CR * E[|x|^2] \quad (15)$$

The filtering process goes this way: an FFT is used to convert the clipped time domain signal C back into the discrete time domain. The in-band discrete frequency components of the clipped signal given as: $C_0, C_{\frac{N}{2}-1}, C_{N\frac{1}{2}-\frac{N}{2}+1}, \dots, C_{N\frac{1}{2}-1}$ are passed unchanged to the inputs of second IFFT while the OOB components: $C_{\frac{N}{2}+1}, \dots, C_{N\frac{1}{2}-\frac{N}{2}}$ are cancelled (Armstrong, 2002a; 2002b; Devi and Ramprabhu, 2018). This process is repeated, depending on the number of iteration, which is commonly chosen between 1 and 4. For the purpose of simulation in this paper, 4 iterations have been chosen.

2.3. 3 Mu-Law Companding Technique

The Mu-Law (or simply written as μ -law) companding technique is a logarithm-based nonlinear method for reduction of PAPR (Ali et al., 2017). The method of operation is that small amplitudes of the signal are enlarged so the difference between the peaks and small values is reduced (Ali et al., 2017; Wang et al., 1999). The mathematical expressions for the output of μ -law companding and decompanding algorithm are given by:

$$C(x) = \frac{v}{\log(1+\mu)} \log\left(1 + \frac{\mu}{v}|x|\right) \text{sgn}(x) \quad (16)$$

$$\bar{C}(r) = \frac{v}{\mu} \left(e^{\frac{|r|\log(1+\mu)}{v}} - 1 \right) \quad (17)$$

where x represents the baseband OFDM signal, r is the received signal after channel, v is the maximum amplitude of the signal x , μ stands for the companding level (whose default value is 255 in practice), and $\text{sgn}(x)$ is the signum function. Equations (16) and (17) are used separately as companding at the transmit end and decompanding at the receive end.

The effect of varying μ on both PAPR (at the transmitter) and BER (at the receiver) has been examined in literature. Study has shown that at low values of μ , the performance of the PAPR reduces quite rapidly and then subsides at high values while the performance of the BER

changes nearly constantly with μ . Hence, small values of μ are recommended to be targeted for best performance (Ali *et al.*, 2017).

2.3.3 LTE Parameter for Simulation Test and Flow Diagram

In order to effectively study the proposed OFDM system model for PAPR reduction, the parameters of the MIMO-OFDM used in this work are that of LTE standard given in Table 1. Figure 1 is the flow chart of the design and implementation approach taken in realizing the objectives in this work.

Table 1: LTE Simulation Test Parameter.

Parameter	Description /value
Modulation	QPSK
FFT Size	256
Spacing	15KHz
Band Width (BW)	1250KHz
Cyclic Prefix (CP)	1/4 of FFT Size
Number of Symbol (nsym)	1×10^3
Sampling Frequency (f_s)	192MHz
Sampling Period (T_s)	192 μ s
Max. Doppler Frequency Shift (F_{Dmax})	0.01Hz

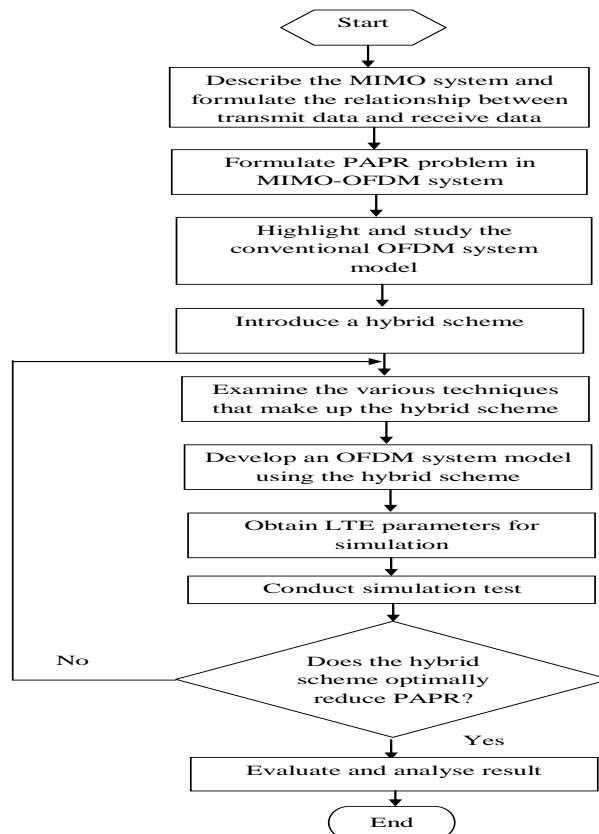

Fig. 2: Flow diagram of the methodology.

3. RESULTS AND DISCUSSION

In this paper, extensive simulations were conducted in MATLAB in order to evaluate the performance of conventional OFDM system, OFDM system with repeated clipping and filtering (RCF) technique, precoding with RCF, OFDM with Mu-law companding technique, and precoding with RCF and Mu-law companding technique, in terms of PAPR reduction. In order to conduct the simulation test, the RCF with OFDM, precoding, Mu-law was studied by selecting clipping ratio (CR) = 3, four iteration process (clipping and filtering, CF1, CF2, CF3, CF4) for effective RCF performance, and oversampling factor (OF), $L = 4$. Also, the Mu-law companding algorithm uses μ value of 100. Finally, simulations were carried out considering only the transmit end. Since PAPR arises and affects only transmit signal, it is appropriate to focus the study direction only on this part of the entire system in order not to create ambiguity and diversion from the main perspective of this paper. Simulation results are shown for conventional OFDM system, OFDM system model integrating RCF algorithm, OFDM system model with precoding and RCF algorithms, adding the Mu-law algorithm to conventional OFDM system model, and combination of precoding, RCF with Mu-law companding techniques for OFDM system model in Fig. 3-7 and Table 2-5.

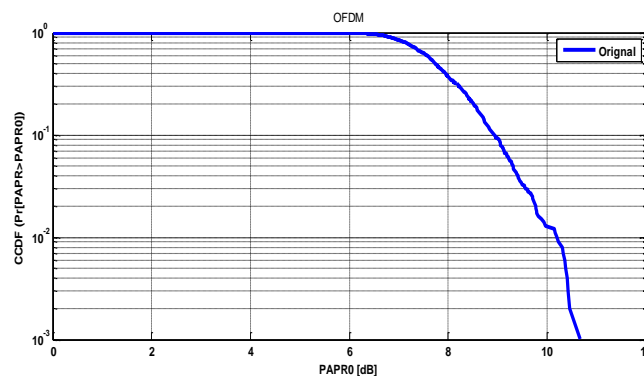

Fig. 3: PAPR of conventional OFDM system model.

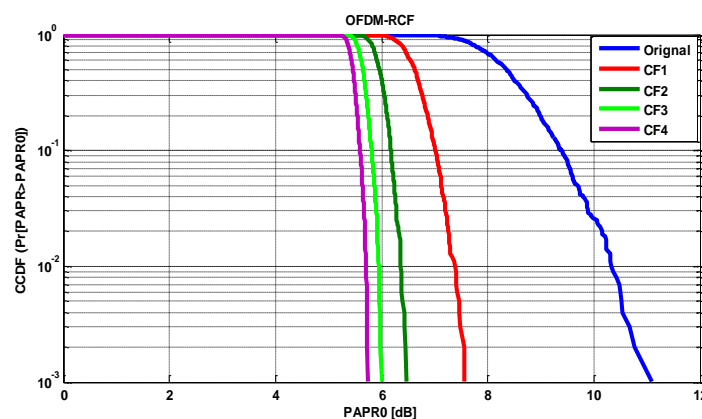

Fig. 4: PAPR of OFDM with RCF with four clipping and filtering process.

In order to calculate the percentage improvement of PAPR, the reference value is taken as that obtained (10.51 dB) from the conventional OFDM system, that is the model without a technique for PAPR reduction. Hence the calculation is done as follows:

$$\%PAPR_{\text{improvement}} = \frac{PAPR_{\text{OFDM_Without}} - PAPR_{\text{OFDM_With}}}{PAPR_{\text{OFDM_Without}}} \times 100 \quad (18)$$

Table 2: Performance analysis of OFDM system model with RCF technique.

Parameter	PAPR Value (dB)	Improvement in PAPR value
Original	11.08	-5.42%
One Clipping and Filtering (CF1)	7.557	28%
Two Clipping and Filtering (CF2)	6.46	38.5
Three Clipping and Filtering (CF3)	6.003	42.88%
Four Clipping and Filtering (CF4)	5.739	45.39%

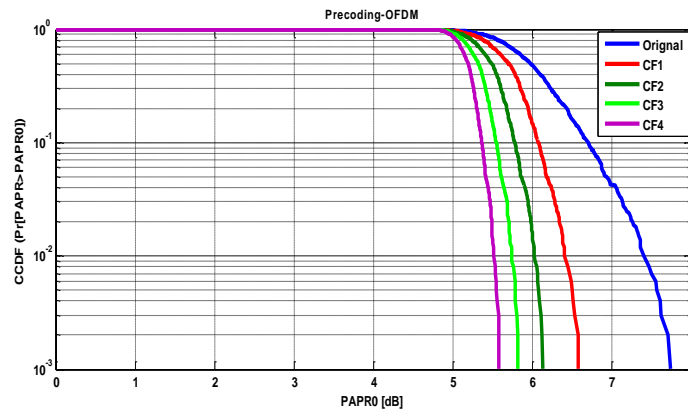

Fig. 5: PAPR of OFDM with precoding plus RCF.

Table 3: Performance analysis of precoding with RCF technique.

Parameter	PAPR Value (dB)	Improvement in PAPR value
Original	7.557	28%
One Clipping and Filtering (CF1)	6.585	37.3%
Two Clipping and Filtering (CF2)	6.131	41.67%
Three Clipping and Filtering (CF3)	5.821	44.6%
Four Clipping and Filtering (CF4)	5.58	46.91%

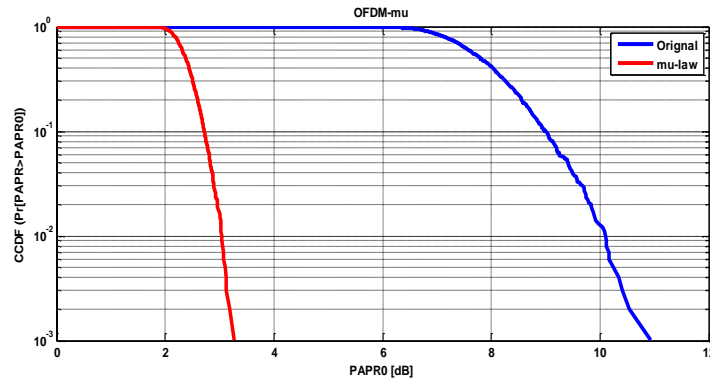

Fig. 6: PAPR in OFDM with Mu-law compandding.

Table 4: Performance analysis of OFDM system model with Mu-law technique.

Parameter	PAPR Value (dB)	Improvement in PAPR value
Original	10.93	4.0%
Mu-law	3.267	68.92%

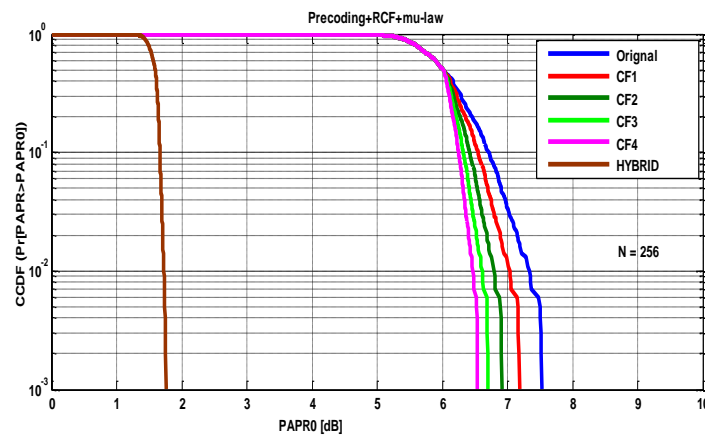

Fig. 7: PAPR OFDM with precoding plus RCF plus Mu-law.

Table 5: Performance analysis of OFDM system model with RCF technique.

Parameter	PAPR Value (dB)	Improvement in PAPR
Original	7.532	28.3%
One Clipping and Filtering (CF1)	7.186	31.63%
Two Clipping and Filtering (CF2)	6.914	34.22%
Three Clipping and Filtering (CF3)	6.704	36.2%
Four Clipping and Filtering (CF4)	6.541	37.76%
HYBRID	1.757	83.28%

The simulations are carried out for 256 data points with QPSK modulation scheme. The size of the OFDM symbol used is equal to 256. With the computation of Complementary Cumulative Distribution Function (CCDF), this work has examined PAPR performance in OFDM using precoding, RCF with Mu-law compandding techniques.

In Fig.3 with the simulation of conventional OFDM system model, the value of PAPR at CCDF 10^{-3} is 10.51dB. With the addition of RCF in the OFDM system, the number of iterations is increased from one to four as shown in Fig. 4. It can be seen that the PAPR reduces as the iterations increases for both clipping and filtering (CF). The plot shows that the more the PAPR reduces the CCDF moves toward the origin. Table 2 shows that the PAPR is reduced to a value of 5.739dB at the fourth iteration (CF4) which is an improvement of 45.39%.

Figure 5 shows the CCDF performance analysis of precoded OFDM with RCF using QPSK modulation for clipping and filtering (CF) with four iterations. The performance in terms of PAPR improves as the number of iterations increases. It can be seen from Table 3 that the introduction of precoder makes the original signal of the OFDM to be equal to 7.557 dB before the application of clipping and filtering for four iterations. Hence, the overall improvement achieved considering the value of PAPR at fourth iteration is 46.91%.

In the simulation result shown in Fig. 6, it can be seen that the addition of Mu-law to conventional OFDM system model has the capacity to reduce PAPR to a very large extent. This is obviously represented in Table 4 which gives the value of the PAPR with Mu-law as 3.267 dB and represents 68.92% improvement of PAPR performance of the OFDM signal. This outstanding performance prompted the development of the proposed hybrid technique that uses the Mu-law companding algorithm to optimize the performance of precoding with RCF technique.

Lastly, while the previous techniques seem promising in reducing PAPR of OFDM signal, the proposed hybrid technique ensures that PAPR is largely minimized in OFDM system. This is shown in Fig. 7. It can be seen that maintaining the same CCDF at 10^{-3} , the resultant effect of applying precoding, RCF with Mu-law companding is minimized PAPR value of 1.757 dB represented by the legend HYBRID in Fig. 7. The analysis in Table 5 shows that an improvement of 83.28% in PAPR reduction from the referenced of OFDM signal value is achieved by the proposed system. Generally, it can be seen that a remarkable reduction of PAPR has been achieved using the proposed system.

4. CONCLUSION

In this study, the performance of a hybrid algorithm for PAPR reduction of OFDM signal has been presented. Since the proposed hybrid model uses combines three algorithms namely,

Precoding, Repeated Clipping and Filtering (RCF), and Mu-law companding so as to optimize the performance of MIMO-OFDM system in terms of PAPR reduction, the performance of the individual algorithm in combination with conventional model was examined. Results obtained indicated that the addition of each algorithm brought about reduction of PAPR of OFDM signal. When only the conventional OFDM model was used the value of PAPR was 10.51 dB. With the introduction of RCF algorithm the value of PAPR was reduced to 5.739 dB, which is 45.39% reduction. Then the OFDM was precoded and then with the RCF algorithm, the PAPR was reduced to 5.58 dB, which is 46.91% reduction. Then the conventional OFDM mode with Mu-law companding algorithm simulated, the PAPR of the OFDM signal was reduced to 3.267 dB, which is 68.92% reduction. Thus, for optimal and improved performance of PAPR reduction, the three algorithms were combined and the outcome showed that the value of the PAPR of OFDM signal was reduced to 1.757 dB, which is 83.28% reduction of PAPR of OFDM signal.

REFERENCES

1. Aboul-Dahab, M.A., Hagra, E.A.A.A., and Elhaseeb, A.A. PAPR Reduction Based on DFT Precoding for OFDM Signals. *International Journal of Future Computer and Communication*, 2013; 2(4): 325-328. DOI: 10.7763/IJFCC.2013.V2.177.
2. Alamouti, S. and Patole, S. A simple transmit diversity schemes for wireless communications. *IEEE Journal on Selected Areas in Communications*, 1998; 16(8): 1451–1458.
3. Ali, N., Almahainy, R., Al-Shabli, A., Almoosa, N., and Abd-Alhameed, R. Analysis of improved μ -law companding technique for OFDM systems. *IEEE Transactions on Consumer Electronics*, 2017; 63(2): 126-134.
4. Amhaimar, L., Ahyoud, S., Elyaakoubi, A., Kaabal, A., Attari, K., and Asselman, A. PAPR Reduction Using Fireworks Search Optimization Algorithm in MIMO-OFDM Systems. *Hindawi Journal of Electrical and Computer Engineering*, 2018; 1-12.
5. Anoh, K., Adebisi, B., Rabie. K.M., and Tanriover, C. Root-Based Nonlinear Companding Technique for Reducing PAPR of Precoded OFDM Signals. *IEEE Access*, 2017; 6: 4618-4629. DOI 10.1109/ACCESS.2017.2779448.
6. Devi, S.N., and Ramprabhu, G. Peak -to - Average Power Ratio Reduction in OFDM using Repeated Frequency Domain Filtering and Clipping (RFC). *SSRG International Journal of Electronics and Communication Engineering (SSRG-IJECE)-Special Issue ICETSST April*, 2018; 102-108.

7. Dubey, S., and Gupta, R. PAPR Reduction in OFDM using Precoding Method, Precoding with Repeated Clipping and Filtering(RCF) Method and Precoding with Clipping Method. *Advances in Computer Science and Information Technology (ACSIT)*, 2016; 3(3): 174-177.
8. Galda, D., and Rohling, H., A Low Complexity Transmitter Structure for OFDM-FDMA Uplink Systems. *IEEE VTC'02*, 2002; 4: 1737-1741.
9. Haque, S.S., and Mowla, M.M. Performance Improvement for Papr Reduction in Lte Downlink System with Elliptic Filtering. *International Journal of Computer Networks & Communications*, 2015; 7(1): 52-61.
10. Jayakumari J. MIMO-OFDM for 4G Wireless Systems. *International Journal of Engineering Science and Technology*, 2010; 2(7): 2886-2889.
11. Manasseh, E., Ohno S., and Jin, Y. Minimization of PAPR in MIMO-OFDM Systems by Tone Reservation Techniques and Pilot Tones. *APSIPA ASC 2011 Xi'an*, 2011; 1-4.
12. Manjula, A V., and Muralidhara, K N. PAPR Reduction in OFDM Systems using RCF and SLM Techniques. *International Journal of Computer Applications*, 2017; 158(6): 6-9.
13. Singh, H., Mohan, C., and Kaur, L. Effective Simulations for PAPR Reduction using RCF with Hard Clipping, Smooth and Dynamic Clipping for QPSK Modulation. *International Journal of Scientific & Engineering Research*, 2013; 4(7): 396-401.
14. Tarokh, V., Jafarkhani, H., and Calderbank, A. R. Space-time block coding for wireless communications: performance results. *IEEE Journal on Selected Areas in Communications*, 1999; 17(3): 451-460.
15. Yi, W., and linfeng, G. An Investigation of Peak-to-Average Power Reduction in MIMO-OFDM Systems. *Blekinge Institute of Technology*, 2009; 1-65.