

MODAL ANALYSIS OF A MOTORBIKE

Ajay G. Malayil^{1*} and Ramesh Kumar R.²

¹Engineer, (MTech in Machine Design), MADRAS RADIATORS AND PRESSINGS LTD., SF NO.98, Palladam road, Othakalmandapam, Coimbatore, Tamil Nadu, India-641032.

²Professor, Department of Mechanical Engineering, Sree Chitra Thirunal College of Engineering, Thiruvananthapuram, India-695018.

Article Received on 17/08/2020

Article Revised on 07/09/2020

Article Accepted on 27/09/2020

*Corresponding Author

Ajay G. Malayil

Post Graduate Student,
Department of Mechanical
Engineering, Sree Chitra
Thirunal College of
Engineering,
Thiruvananthapuram,
Kerala, India-695018.

ABSTRACT

Dynamic response of a 350cc bike having tubular chassis out of AISI 4130 alloy steel is studied considering the actual geometric data and stiffness distribution with engine and passenger masses and replacing spring mass system for the wheel and tire assembly. The fundamental frequency of the bike is observed as 12.7Hz and comparison with the reported frequency when structural mass alone is considered for 150cc bike is seen in the expected range. Fixity of engine mounting brackets makes the design insensitive with the wheel assembly. Under

gravitational load the induced stresses are much lower as expected with a margin of safety of three with respect to the endurance limit value of the alloy steel. Structural elements that possess low frequency have been identified. Participating mass of the engine for respective mode shapes shows that engine mass location is quite safe and ideal.

KEYWORDS: *Beam element, Lumped Mass, Modal Analysis, Motorbike.*

I. INTRODUCTION

A chassis of a bike consists of an inner framework that supports a man-made object. It is analogous to an animal's skeleton. An example of a chassis is that consisting of the frame (on which the body is mounted) with the wheels and machinery. In the case of vehicles, the chassis consists of the frame along with the running gear like engine, transmission, driveshaft, differential, and suspension. A body that is usually not necessary for the integrity

of the structure is built on chassis to complete the vehicle. The automotive chassis is tasked with holding all the components together while driving and transferring vertical and lateral loads caused by accelerations on the chassis through the suspension and the wheels. Santhosh *et al.*, based on experimental modal analysis considering only structural mass, determined the natural frequency as 19Hz besides damping and mode shapes of two types of chassis belongs to 150cc motorbike named Pulsar and bike Passion bike.^[1] Pulsar was identified as a safe design among the two types. The chassis of the former undergone lower deformation than the latter. Rahul and Kishore carried out dynamic analysis of a bicycle using a 3-D model to assess the key characteristics of a bicycle chassis and reported that mild steel option was better than aluminum material in terms of optimum mass and strength.^[2] A similar approach of motorbike chassis was followed by Pavana and Sayyad and the design by aluminum alloy 6063 instead of mild steel for better mass reduction and strength.^[3]

In the present study, dynamic response of Royal Enfield Thunderbird 350 is carried out to identify the low frequency structural elements in the chassis and assess the structural margin under gravitational load with measured geometry, dimensions, and distribution of stiffness and mass.

A. Design Specification of Motorbike

The technical specifications of Royal Enfield Thunderbird 350 are given in Table 1.^[4] Figure 1 shows the schematic diagram of the bike indicating various load bearing members. The cross-sections of the elements are tabulated in Table 2 to determine EI values. The engine is mounted to the frame by foundation bolts.

Table 1: Technical specifications of RE Thunderbird 350.^[4]

I. Engine	
Type	Single cylinder, 4 stroke, twinspark, air-cooled
Displacement	346cc
Bore x stroke	70 mm X 90 mm
Compression ratio	8.5 : 1
Maximum power	19.8 bhp @ 5250 rpm
Maximum torque	28 Nm @ 4000 rpm
Ignition system	Transistorized coil ignition
Clutch	Wet, multi-plate
Gearbox	5 speed constant mesh
Lubrication	Wet sump
Engine oil	15 W 50 API, SL grade & above, JASO MA 2
Fuel supply	29mm, constant vacuum carburetor
Air cleaner	Paper element

Engine start	Electric/kick
II. Chassis and Suspension	
Type	Single downtube, using engine as stressed member
Front suspension	Telescopic, 41 mm forks, 130 mm travel
Rear suspension	Twin gas charged shock absorbers with 5-step adjustable preload, 80 mm travel
III. Dimensions	
Wheelbase	1350 mm
Ground clearance	135 mm
Length	790 mm (Without mirrors)
Height	1205 mm (Without mirrors)
Kerb weight	197 kg (with 90% fuel & oil)
Fuel capacity	20litre
IV. Brakes and Tyres	
Tyres front	90/90 - 19
Tyres rear	120/80 - 18
Brakes front	280mm Disc, 2-piston caliper
Brakes rear	240mm Disc, single piston caliper
V. Electricals	
Electrical system	12 volt - DC
Battery	12 volt, 8Ah
Head lamp	Projection type headlamp, H7 55 / 55 W
Tail lamp	LED lamp with position light guides
Turn signal lamp	12V, 10W x 4 Nos



Figure 1: Schematic diagram showing elements in a Royal Enfield Thunderbird 350 chassis.

In Figure 1 the elements which constitute the bike chassis are shown. Element 1 is the front fork assembly which consists of two front forks and two triple clamps. This element connects the front wheel to the motorbike chassis. Element 2 is the headstock. This part allows the stem of the triple yoke to couple with it thereby connecting the front fork assembly with the chassis. Element 3 is the single downtube. This element connects with the front part of the

engine through a foundation bolt. Element 4 is the head tube of the chassis where the fuel tank rests. Element 5 is the center tube. Element 6, Element 7, Element 8 and Element 12 constitutes the tail tube. The bottom part of the engine is held by Element 12 by foundation bolt. Element 9 is the swing arm assembly. This element connects the rear wheel to the motorbike chassis. Element 10 is the subframe. This element act as the seating area for the rider and pillion. Element 11 is the swing arm frame. This element connects the swing arm with the chassis. The top backside of the engine is connected to the tail tube.

B. Assumptions followed

The following assumptions are considered:

1. Damping of shock absorbers is not considered.
2. The engine mounting frame is considered rigid.
3. The endurance limit is assumed as 50% of the ultimate tensile strength.
4. For the free vibration analysis, the engine response is not considered.
5. The wheel is represented as a spring with spring constant as 200kg/mm.
6. Hardpoint for boundary condition is chosen at the engine mounting brackets.

Table 2: EI values of structural elements (t = 3mm and E=210GPa).

Element Numbers (Fig. 1)	1	2-3	4	5	6-8	9*	10-12
D (Φ, mm)	41	43	38	31.8	21.6	570 x 30 x 50	21.6
I, mm ⁴	650477	75822	50882	28447	7778	142132	7778

*Box element (Length x Breadth x Height)

C. Material Selection

It is found that the frame is made of mild steel. The material for the frame is taken as AISI 4130 ALLOY STEEL. The properties for the assigned material are shown in Table 3.

Table 3: Material Properties of AISI 4130 Alloy Steel.^[5]

Material	AISI 4130 Alloy Steel
Young's Modulus, E & Poisson's ratio	210GPa & 0.3
Mass Density	7830kg/m³
Ultimate Tensile Strength, σ_{ult}	560MPa
Endurance Limit (assumed)	250MPa

D. Masses considered

The main weight acting on a motorbike chassis is the engine followed by the fuel tank. Passengers' weight includes the rider and pillion are considered as external loads acting on the

chassis. The weights considered for the finite model are shown in Table 4.

Table 4: Lumped masses considered in the model.

Masses considered	Value (kg)
Engine mass & Fuel tank mass	50 and 20
Rider and passenger mass	2 x 80

II. METHODOLOGY

The dimensioning and material selection of actual motorbike is used as a reference for present analysis. Initially a 3D CAD model of the motorbike is created with appropriate section modulus. Finite Element model of the model is created by using beam elements. Then working loads are given in terms of lumped masses on the finite element model. Lower frequency parts are identified with respect to the position of lumped masses.

A. Preparation of 3D CAD model

The motorbike chassis model is made by using real-time data. Measurements were taken from the onsite model for the CAD model generation. Creo software is used for modeling.

B. Boundary conditions

A total of 381 quadratic line elements and 782 nodes are present in the finite model. All six degrees of freedom are constrained at the lower part of the tail tube where the engine is supported as shown in Figure 2.

As per the design specifications of the motorbike from Table 1, the front tire size is 90mm/90mm-19'' and rear tire size is 120mm/80mm-18''.^[4] The front wheel radius is 331mm which is higher than than the rear wheel radius of 308mm. Both the wheel dimensions are verified through measurements. Front and rear wheels are replaced by springs of stiffness 200kg/mm. Three springs at an angle of 12⁰ with respect to each other are considered at each wheel location (Figure 2). This arrangement of springs results in a cone angle of 24⁰

C. Cases considered for modal analysis

Four different cases are considered for the model depending on the mass acting on the model. In the first case, the engine mass alone is considered on the motorbike chassis. For the second case, the engine weight and the fuel tank weight are considered. In the third case, the rider weight is considered along with the engine weight and fuel tank weight. For the fourth case,

the pillion weight is added to the third condition which resembles the two passengers on the bike condition. The distributed lumped masses are shown by ten square symbols and one square symbol for the engine mass in Figure 2.

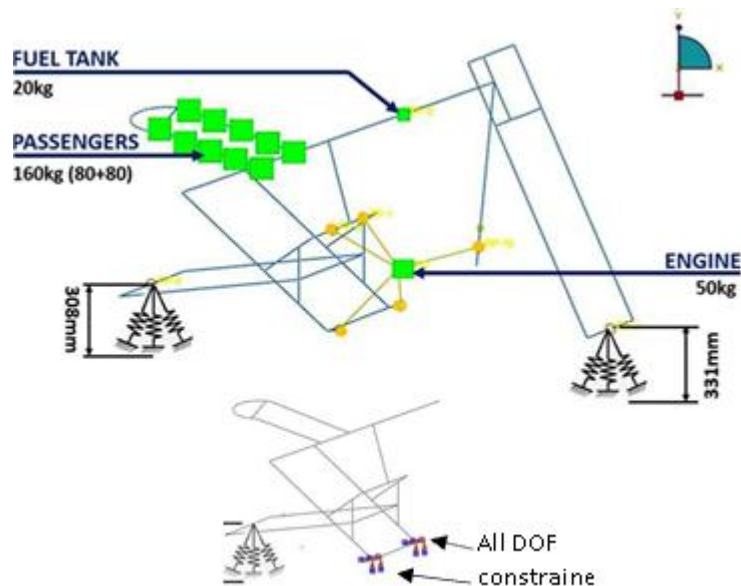

Figure 2: Boundary conditions, spring mass system and lumped masses considered.

III. RESULTS AND DISCUSSIONS

The first fundamental frequency and mode shapes of the motorbike with engine mass alone, engine mass, fuel tank, and single rider masses and further with two passenger masses are shown in Figure 3. Convergence studies based on quadratic and cubic polynomial beam elements for the evaluation of frequencies are given in Table 5. The modal frequencies of the motorbike for the critical case considering all types of masses mentioned in Table 4 are given in Table 6. Displacements and stresses under gravitational load are given in Figures 5-6.

A. Modal Analysis of the motorbike

From Table 5, it can be noticed that the convergence study based on second and third-order polynomials for the beam element shows a deviation of 2 to 11% for the cases considered even though models are expected to give the same values. As expected, the modal analysis results for engine mass and with the addition of fuel tank are found to be almost the same. The natural frequency of the motorbike is estimated at 12.7Hz. It is observed that for the case of engine mass of 50kg, the frequency values are respectively, 14.2Hz and 14.4Hz for quadratic and cubic beam elements. The results are tabulated in Table 5. The influence of lumped masses on the fundamental frequencies of the motorbike can be seen in Table 5.

Table 5: Convergence study on modal analyses.

No.	Masses considered	Mode 1 Frequency (Quadratic beam element)	Mode 1 Frequency (Cubic beam element)
1.	Engine	14.2Hz	14.4Hz
2.	Engine and Fuel tank	14.2Hz	14.4Hz
3.	Engine, Fuel tank and Rider	13.6Hz	14.0Hz
4.	Engine, Fuel tank, Rider and Pillion	11.3Hz	12.7Hz

Modal analysis is basically aimed to identify the critical structural element with low frequency. For all the cases the maximum normalized amplitude is noted at the front fork assembly thus identifying front fork as the critical structural element. It is observed that the frequency reduces as expected with the passenger mass as shown in Table 5. Six modal frequencies are tabulated in Table 6. It is observed that the first two modes are quite nearby while the 6th mode frequency is 127Hz which is ten times higher than the fundamental frequency.

Table 6: Mode frequencies for finite element model with cubic beam elements.

Mode	Mode Frequencies, Hz
1	12.7
2	16.4
3	46.6
4	67.1
5	79.0
6	124.2

For the case of two passengers with a total mass of 160 kg the frequency reduces to 11.3Hz when compared to a single passenger of 80kg with a frequency of 13.6Hz as seen in Figure 3.

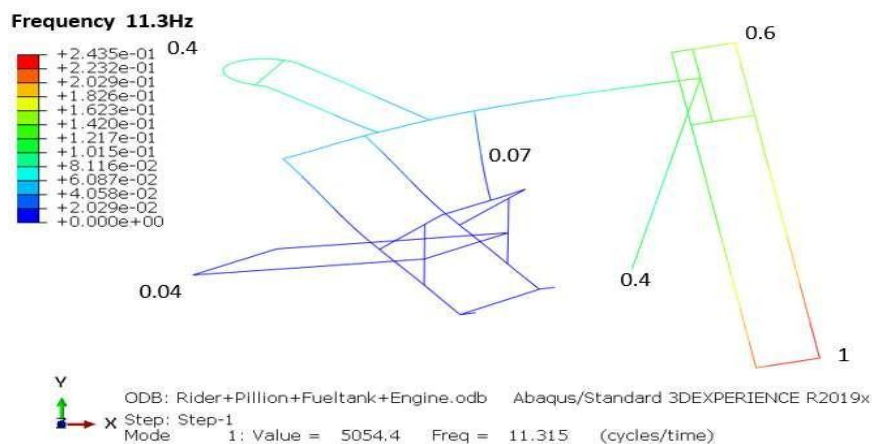
**Figure 3: Normalized natural frequencies of the motorbike with engine mass, fuel tank mass and two passenger mass.**

B. Mode shape at higher mode

It may be observed that for mode -3 the frequency increases as much as three times with the rear part of the bike is influenced by the response even though the peak response is at the front fork as shown in Figure 4.

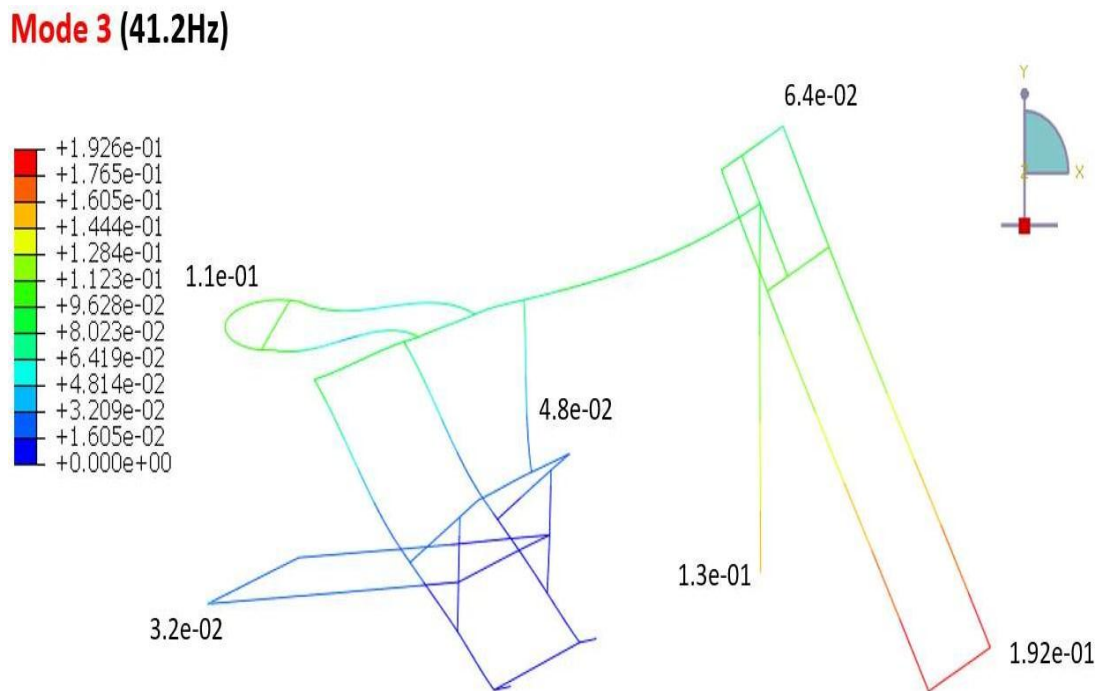

Figure 4: Mode shape of motorbike at higher mode.

C. Static analysis of the motorbike

Static analysis is carried out for '1g' loads along with the mutually perpendicular directions and the displacements and stresses induced on the bike are studied (Figures 5-6). Since '2g' load conditions are considered the stress obtained from the 'g' load test is doubled for the structural margin evaluation. Thus for '2g' load condition, the maximum stress of 70 MPa is observed at the location close to the passenger seat. Severe bending causes with respect to support tubular elements. The maximum displacement and maximum stress have been observed for g load in the vertical direction of the motorbike. A margin of 3 is observed at the expected endurance limit which is assumed as half of the tensile strength 560MPa that is 280MPa.

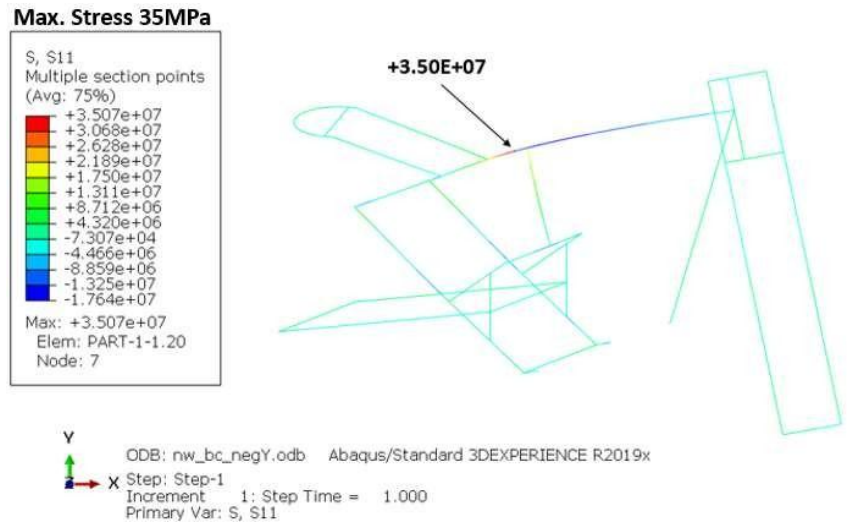

Figure 5: Maximum stress observed for 1g load.

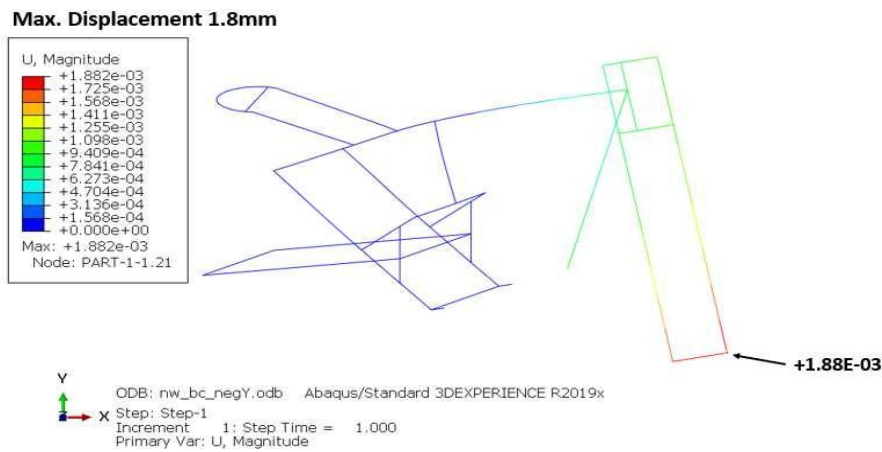

Figure 6: Maximum displacement observed for 1g load.

D. Participating mass under first mode

It is observed that for the first mode frequency the participation mass of the engine in the transverse direction is almost negligible as expected while in the vertical direction it is 7.80kg corresponding to the engine mass of 50kg as shown in Table 7. The participating mass of the engine and respective mode of frequency shows that engine mass location is quite safe.

Table 7: Engine mass for each higher mode of frequency

Mode No.	Running axis of the bike (kg)	Vertical direction (kg)
1	5.90E-03	7.88
2	11.77	2.53E-02
3	0.45	5.79
4	3.19	0.18
5	6.05E-02	0.17
6	8.17E-02	2.21

IV. CONCLUSION

Free vibration analysis of the 350cc bike has been carried out considering measured geometric data for input on the stiffness with lumped masses for engine, tank, and rider using beam element and replacing rim and tires by spring element. A fundamental frequency of 12.7Hz is achieved. A comparison of the frequency with the bare structural mass of the 350cc bike shows 14.4Hz as against 19Hz for the case of 150cc bike. Fork of the bike is identified as the critical structural element.

It has been observed that the fixity of engine mounting brackets treats the bike as two front and rear cantilever beams by which wheel-tire assembly has very low influence! A very high margin of safety is found under gravity loads with respect to the strength corresponding to the endurance limit. Participating mass of engine obtained from the analysis for the respective modes of frequencies has shown that engine mass location is quite safe.

REFERENCES

1. Santosh H., Naresh K., Nagareddy G., and Lakhan R., "Modal analysis of two-wheeler chassis", *International Journal of Engineering Sciences & Research Technology (IJESRT)*, 2016; 5: 68-73.
2. Rahul J. P., and Dr. Kishor P. K. "Vibrational analysis of bicycle chassis", *International Journal for Innovative Research in Science & Technology (IJIRST)*, 2016; 3: 136-148.
3. Pavana S. P., and Dr. F. B. Sayyad "Theoretical and experimental validation of a bike chassis for weight reduction", *International Journal of Scientific & Technology Research*, 2016; 5: 4-11.
4. Technical specifications of Royal Enfield Thunderbird 350cc. [Online] Available:<https://www.royalenfield.com/in/en/motorcycles/thunderbirdmodels/thunderbird-350/#motorcycle-specifications>.
5. Material Properties of AISI 4130 Alloy steel [Online] Available: <http://www.astmsteel.com/product/4130-steel-aisi-25crmo4-7218-scm430/>.