

**IMPROVING DESIGN MANAGEMENT IN PALM KERNEL NUT
CRACKING AND SEPERATING MACHINE ANALYSIS**

*¹Rufus Ogbuka Chime and ²Emmanuel Anayo Agwu

¹Mechanical Engineering Department Institute of Management and Technology (IMT)
Enugu, Enugu State, Nigeria.

²Engineering Regulation Monitoring Department, Council for the Regulation of Engineering
in Nigeria, Wuse Zone 4, Abuja, Nigeria.

Article Received on 21/01/2021

Article Revised on 11/02/2021

Article Accepted on 01/03/2021

***Corresponding Author**

Rufus Ogbuka Chime

Mechanical Engineering
Department Institute of
Management and
Technology (IMT) Enugu,
Enugu State, Nigeria.

ABSTRACT

Every one of us is a manager of projects of our own life. From a house wife to an employee to financial analyst, from banker to doctor, from engineer to administrator, from a teacher to a student, we all work on different tasks with deadlines. Regardless of our occupation, norms, or location in an organization, we all work on tasks that are full of risks and involve people who do not usually work together. The project may

have a simple goal that does not need many people or a great deal of money or it may be quite complex, calling for diverse skills and overabundance of resources. But the bottom line is that every one of us manages project. Palm kernel is eatable seed of the oil palm tree and the fruit is commonly known for its usefulness in producing two types of oil; palm kernel oil from the kernels and palm oil from the fleshy parts of the fruit. Palm kernel is originally from Africa especially Nigeria, Guinea, Angola and the Gambia before spreading to other parts of the world. The oil palm plant is one of the most important crops grown in the tropics. Nigerian is known as one of the leading exporters of palm oil. There are basically three distinct varieties of palm kernel fruit. These are the Dura, Tenera and Pisifera. The Dura have large kernel, Tenera have medium kernel, and Pisifera have small or no kernel. The palm oil plant is a cash crop that has a wide variety of uses through the oil extracted from the seed and from the fleshy part of the plant. Palm oil is mainly used for the manufacture of soap, production of margarine, lubricating oils, and candle. It is also used in tin plate and sheet

steel industries. Palm kernel oil has application in the making of soap, margarine and drugs etc. The kernels are not useful until the kernels are separated from the shell, however, the usual way of cracking palm nut to get kernel is a time consuming and labor intensive process. The machine was developed to tailor for all the physical characteristics of the palm kernels varieties such as the different sizes of palm kernel nuts , the shell and kernel ‘The objective of design management is to develop and maintain an efficient business environment in which an organization can achieve its strategic and mission goals through design . As a result of researching innovation have been made to solve the problem of traditional method by using mechanized type. our aim is to ensure that the product can be manufactured at a feasible cost, presented followed by the computer-based area of virtual manufacturing for simulating manufacturing operations, Simulation analysis of the models and design was carried out using Autodesk inventor professional application. The machine was designed using solid work/solid edge and Microsoft Project software. The efficiency of the machine, its associated cost of production and the product obtained after few minutes of cracking were outstanding, thereby, making the design acceptable and cost effective.

KEYWORDS: Design management, modelling, simulation, sustainability and analysis.

INTRODUCTION

Currently, organizations all over the world are increasingly looking for ways to employ the power of design in product innovation, in every day management processes, and in the creative development of their companies. When design effectively and creatively engages with business agendas, the results are of benefit to people, products, processes and organizational cultures as a whole. There is a need to educate an increasing number of people in design management techniques to equip them to manage today’s fast moving and demanding projects. However, many current design management tools are insufficiently developed for industry application. Design has become a strategic asset in brand equity, differentiation, and product quality for many companies. More and more organizations apply design management to improve design-relevant activities and to better connect design with corporate strategy, Therefore, to improve design management in the industry, current techniques must be modified to align them with the needs of the modern design manager. Therefore, Microsoft Project is the modern tool of Project Management that aid to overcome the challenges faced during planning and management that may come up with project failure due to lack of skills and using local means. It ensures the project manager for the optimum

and effective organization of activities which helps to give the vision to complete the project in planned duration, cost and meet the scope.

An improve cracker is needed for the cracking of palm kernel in large scale to satisfy this ache. The process of palm kernel oil needs a nut shell cracking which is the most critical and delicate aspect which is labour exhaustive if done manually. Common traditional procedures of breaking palm kernel nuts in rural areas where it is produced involved a lots of work and hazard. Methods of cracking oil palm nuts at the village level which is still being used in many parts of the country's (Nigeria). The first method employs the principle of impact in achieving kernel cracking. This is done by placing about 7nuts on a flat stone and using another stone as a hammer to crack them, mostly done by women and children. Apart from the drudgery, time consumption and health hazards that are likewise associated with this process, addition winnowing may be necessary as sizeable quantity of fibre is still retained in the nuts. Peasant farmers break the nuts one at a time between two stones by experience.

The individuals involved in the manual cracking risk their selves of inadvertently hitting their fingers with the impact stone. The palm kernel cracking machine is power driven and it is built so as to increase efficiency of cracking the nuts, reduce accidents during operation and minimize the expelling of time during the process). The unit operates in the form of an agitated basket, and is stimulated by the vibration effect from the electric motor; an action which toggles it forward, backward and sideways. This crushing ensures that the variation in size between the kernel seeds and the shells is large, hence the feasibility of the sieving-separation approach. More so, the diameter of the mesh grooves selected is smaller than the average kernel seed diameter (15mm), and this ensures that the kernel seeds are not ejected along the sorting route. The sorting tray is inclined at an angle to the horizontal, thus ensuring that the kernels seeds freely slide over the mesh grooves while the shells are properly expelled from the mesh grooves. Due to the continuous increase in demand for palm kernel nuts for soap, cream, and cooking oil, there is need to produce it with local source materials.

1.1 Problem Statement

The process of palm kernel oil needs a nut shell cracking which is the most critical and delicate aspect which is labour intensive if done manually. Common traditional techniques of breaking palm kernel nuts in rural areas where it is produced involved a lots of drudgery and hazard. The individuals involved in the manual cracking endanger their selves of unintentionally hitting their fingers with the impact stone. The palm kernel cracking machine

is power driven and it is constructed so as to increase efficiency of cracking the nuts, reduce mishaps during operation and minimize the exercising of time during the process.

1.2 Aim

To develop a low cost, easy-to-use machine. With Local source materials which will be used comfortably, effectively, for rural dweller.

1.3 Objectives

To design cracking and separating machine that maintenance cost and separating time will be reduced. The operation of the machine will not require special skill, the machine will be easy and safe to operate, it will be noise and vibration free.

The outcome of the research will contribute to sustainability analysis of palm kernel machine which will have the following contributions - Teaching aids, economic development and job creation for Nigerian farmers.

1.4 Justification of Project

The cracking of the palm nuts is carried out manually by: Stone Arrangement, Mortar and pestle method. These techniques are part of the earliest and simple methods of cracking oil palm nuts at the village level which is still being used in many parts of the country's (Nigeria). The first method employs the principle of impact in achieving kernel cracking. This is done by placing about 6 nuts on a flat stone and using another stone as a hammer to crack them, and mostly done by women and children. Apart from the drudgery, time consumption and health hazards that are likewise associated with this process. winnowing is necessary as sizeable quantity of fibre is still retained in the nuts. Farmworkers break the nuts one at a time between two stones by experience. The innovation type of the palm kernel cracking machine is power driven and it is built so as to increase efficiency of cracking the nuts, reduce accidents during operation and minimize the exercising of time during the process.

LITERATURE REVIEW

Managing the design process is challenging due to the nature of design (Knotten et al., 2015). The design management can be divided in two parts, the management of the process and leading the design. The management is trying to keep the process on time, at budget and with the right quality. The design leader is trying to get the most of knowledge and creativity

of the team. The high flow of information, and the need of decisions call for a strong collaborative environment. There have been some efforts to describe ways of collaborative design management (e.g. (Emmitt& Ruikar, 2013; Fundi and Drevland (2014) highlighted the importance of a start-up meeting in the project. A start-up meeting with the project team had positive effect on cooperation, communication and commitment of the team members.

The individual fruit ranging from 60 to 70g and made up of outer skin (exocarp), a pulp (mesocarp), which contain the palm oil in a fibrous matrix, a central nut consisting of a shell (endocarp) and the kernel which itself contain an oil that is quite different from palm oil, but resembles coconut oil (FAO, 2004).

Cracking of the palm kernel nut by traditional methods: The first method employs the principle of impact in achieving kernel cracking. This is done by placing about 6 nuts on a flat stone and using another stone as a hammer to crack them, and mostly done by women and children. The method is crude and the kernel recovery is slow, uneconomical, labour intensive and sometimes hazardous to the operator. The output may be up to 50kg of kernel in a working day per worker (Schultes, 1990). This method is so slow to the extent that it cannot match the demand for palm kernel requirement both locally and for export.

Emmitt, 2013; Mejl ander-Larsen, 2015). in the interpersonal relations of the design team itself. The design team or the people doing the design are important for the result. Dainty et al. (2007) points out the industry's ability to improve are limited by how the people are managed." Buildings require the combined efforts of many individuals, working and designing collaboratively to provide value to their clients" (Emmitt & Ruikar, 2013). Boyle (2003) states that a key factor for achieving success in AEC projects is directly linked with the personnel involved, i.e. the team.

Design management is a field of inquiry that uses project management, design, strategy, and supply chain techniques to control a creative process, support a culture of creativity, and build a structure and organization for design. The objective of design management is to develop and maintain an efficient business environment in which an organization can achieve its strategic and mission goals through design. Design management is a comprehensive activity at all levels of business (operational to strategic), from the discovery phase to the execution phase. "Simply put, design management is the business side of design. Design management encompasses the ongoing processes, business decisions, and strategies that

enable innovation and create effectively-designed products, services, communications, environments, and brands that enhance our quality of life and provide organizational success. The discipline of design management overlaps with marketing management, operations management, and strategic management.

Traditionally, design management was seen as limited to the management of design projects, but over time, it evolved to include other aspects of an organization at the functional and strategic level. A more recent debate concerns the integration of design thinking into strategic management as a cross-disciplinary and human-centered approach to management. This paradigm also focuses on a collaborative and iterative style of work and an additive mode of inference, compared to practices associated with the more traditional management paradigm. Design has become a strategic asset in brand equity, differentiation, and product quality for many companies. More and more organizations apply design management to improve design-relevant activities and to better connect design with corporate strategy.

Improving business processes will increase efficiency and get free of activities that waste time and resources.

Effectiveness: As business processes become more efficient, they also become more effective. This will lead to better-informed decisions, better execution of necessary tasks, and improved customer experiences

2.2 Design

Unlike unique sciences such as mathematics, the perspective, activity, or discipline of design is not brought to a generally accepted common denominator. The historical beginnings of design are complex and the nature of design is still the subject of ongoing discussion. In design, there are strong differentiation between theory and practice. The fluid nature of the theory allows the designer to operate without being constrained by a rigid structure. In practice, decisions are often referred to as perception. In his *Classification of Design* (1976), Gorb divided design into three different classes. Design management operates in and across all three classes: product (e.g. industrial design, packaging design, service design), information (e.g. graphic design, branding, media design, web design), and environment (e.g. retail design, exhibition design, interior design). shown in figure 35

2.3 Management

Management in all business and organizational activities is the act of getting people together

to accomplish desired goals and objectives efficiently and effectively. Management comprises planning, organizing, staffing, leading or directing, and controlling an organization (a group of one or more people or entities), or effort for the purpose of accomplishing a goal. Resourcing encompasses the deployment and manipulation of human resources, financial resources, technological resources, and natural resources. Towards the end of the 20th century, business management came to consist of six separate branches, namely human resource management, operations management (or production management), strategic management, marketing management, financial management, and information technology management, which was responsible for management information systems. Although it is difficult to subdivide management into functional categories in this way, it helps in navigating the discipline of management. Design management overlaps mainly with the branches marketing management, operations management, and strategic management

2.4 Engineering Design Management

Engineering Design Management is a knowledge area within engineering management. It represents the adaptation and application of customary management practices, with the intention of accomplishing a productive [engineering design process]. Engineering design management is primarily applied in the context of engineering design teams, whereby the activities, outputs and influences of design teams are planned, guided, monitored and controlled. The output of an engineering design process is ultimately a description of a technical system. That technical system may either be an artefact (technical object), production facility, a process plant or any infrastructure for the benefit of society. Therefore, the domain of engineering design management includes high volume, mass production as well as low-volume, infrastructure.

2.5 Design Policy

Design policies have a history reaching back to the end of the 19th century, when design programs with roots in the crafts sector were implemented in Sweden (1845) and Finland (1875). In 1907 the Deutscher Werkbund (German Work Federation) was established in Munich to better compete with Great Britain and United States. The success of the Deutscher Werkbund inspired a group of British designers, industrialists and business people after they had seen the Werkbund Exhibition in Cologne in 1914, to found the Design and Industries Association and campaign for a greater involvement of government in the promotion of good design. In 1944 design management by managing design policies was used by the British

Government. The British Design Council was founded by Hugh Dalton, president of the Board of Trade in the British wartime government, as the Council of Industrial Design with the objective "to promote by all practicable means the improvement of design in the products of British industry".

Germany also realized the national importance of design during World War II. Between 1933 and 1945 Adolf Hitler used design, architecture and propaganda to increase his power; shown through the annual Reich wikip is parentage in Nürnberg on September 5. Heinrich Himmler coordinated several design activities for Hitler, including: the all-black SS-uniform designed by Professor Karl Diebitsch and Walter Heck in 1933; the Dachau concentration camp, designed by Theodor Eicke, and prototypes for other Nazi concentration camps; and the Wewelsburg redesign commissioned by Heinrich Himmler in 1944. Since the 1990s the practice of design promotion evolved, and governments have used policy management and design management to promote design as part of their efforts of fostering technology, manufacturing and innovation.

Difficulties arise in tracing the history of design management. Even though design management as an expression is first mentioned in literature in 1964, earlier contributions created the context in which the expression could arise. Throughout its history, design management was influenced by a number of different disciplines: architecture, industrial design, management, software development, engineering, and movements such as system theory, design methodologies. It cannot be attributed directly to either design or to management.

The machine was developed to cater for all the physical characteristics of the palm kernels varieties (Dura and Tenera) such as the different sizes of palm kernel nuts (from local sampling), the shell and kernel, the weight of palm kernel and as well as coefficient of friction for shell and kernel with respect to carbon steel was put into consideration. For best performance to be realized before the building of the machine, different palm kernel nuts were arbitrarily picked and measured with average measurement sizes of 11.0 to 25.0 mm in diameter and the thickness size of shell ranged from 0.8 to 2.7 mm.

The cracked shell can be used for road constructions, brake pads and coarse aggregate in concrete for building (Mahmud et al., 2009). The chaff and shell are used locally for the manufacture of candles and as fuel for cooking. Thus, every part of the palm fruit or its by-

products is economically useful (Patrick and Godspower, 2014).

In the processing of kernel oil, nut shell cracking is the most critical and delicate operation. Its major concern is to extract the fragile kernel whole from the shell. Cracking palm nuts to release the kernels is a critical step that affects the quality of kernel oil. There are two types of modern palm kernel crackers; the hammer impact and the centrifugal impact types. These modern crackers are not free of limitations. Hammer impact type breaks or cracks the nut on impact when the hammer falls on it; while centrifugal impact nut cracker uses centrifugal action to crack the nut (Ndukwu and Asoegwu, 2010). The effective separation of the cracked palm nut mixture is an important process in the utilization of the constituent palm kernel and the shell in some existing and emerging agro-economy. The kernels are not useful until they are separated from the shell.

The usual way of cracking palm nut to get the kernel is a time consuming and labor intensive process (Oke, 2007). Researchers have employed several methods and media like water, clay, carpets fans, blowers and sieves to separate palm kernels from the shell but nobody has reported success rate above 60% for the separation of palm nut and shell.

The usage of methods including clay and water further complicates the separation process as heat would be needed in order to dry the shell before they can be stored (Oguoma et al., 1993; Obiakor and Babatunde, 1999; Koya and Faborode, 2006). Conventionally, palm kernel cracking machines usually work on the principle of impact either using centrifugal means to deliver the energy or using the hammer mill.

2.6 Material Selection

Most machine and tools are constructed from metallic and non-metallic materials. The metals are divided into two groups' ferrous metals: are those which have the iron as their main constituent such as cast iron, wrought iron and steel. Non-ferrous metals: are those which have a metal other than iron as their main constituent such as copper, aluminium, brass, tin, zinc etc.

The selection of a proper material, for engineering purposes, is one of the most difficult problems for the designer. The best material is one which serves the desired objective at the minimum cost. The following factors are considered while selecting the material:

- Availability of the materials.

- Suitability of the materials for the working conditions in service.
- The cost of the materials.

2.7 Modern Manufacturing

Manufacturing technologies address the capabilities to design and to create products, and to manage that overall process. Product quality and reliability, responsiveness to customer demands, increased labor productivity, and efficient use of capital were the primary areas that leading manufacturing companies throughout the world emphasized during the past decade to respond to the challenge of global competitiveness. As a consequence of these trends, leading manufacturing organizations are flexible in management and labor practices, develop and produce virtually defect-free products quickly (supported with global customer service) in response to opportunities, and employ a smaller work force possessing multidisciplinary skills. These companies have an optimal balance of automated and manual operations. To meet these challenges, the manufacturing practices must be continually evaluated and strategically employed. In addition, manufacturing firms must cope with design processes (e.g., using customers' requirements and expectations to develop).

2.8 Virtual Products

There are a myriad number of uses that can be made of the virtual product created through PSM (Product Specification Management consists).. In the manufacturing or build phase, the "as-built" virtual product is immediately available and can be transmitted to customers and other parties in the supply chain who need the information about the product to assure themselves that the product is actually being created to the required specifications and Customer requirement illustrated in figure,1, figure,7 etc.

2.9 Safety

Safety is related to external threats, and the perception of being sheltered from danger. According to the business Dictionary, safety is defined as a relative freedom from danger, risk, or threat of harm, injury, or loss of personnel and/or property, whether caused deliberately or by accident. Safety can also be defined as the control of recognized hazards to achieve an acceptable level of risk. In this study, safety means freedom from danger, harm, and injury to the person involved in construction activities. Safety is related to external threats, and the perception of being sheltered from danger. According to the business Dictionary, safety is defined as a relative freedom from danger, risk, or threat of harm, injury,

or loss of personnel and/or property, whether caused deliberately or by accident. Safety can also be defined as the control of recognized hazards to achieve an acceptable level of risk. Illustrated figure 13 and table 1

2.10 Customer and Engineering Requirements

Requirement

In product development and process optimization, a requirement is a singular documented need that a particular design, product or process must be able to perform. It is most commonly used in a formal sense in systems engineering, software engineering or enterprise engineering. It is a statement that identifies a necessary attribute, capability, characteristic, or quality of a system for it to have value and utility to a customer, Organization, internal user, or other. A requirements specification (often imprecisely referred to as the **spec**. Because there are different sorts of specification) refers to an explicit set of requirements to be satisfied by a design, product or services.

In the classical engineering approach, sets of requirements are used as inputs into the design stages of products development. Requirements are also an important input into the verification process, since tests should trace back to specific requirements. Requirements show what elements and functions are necessary for the particular project. This is reflected in the waterfall model of the software life cycle. However, when iterative methods of software development or agile methods are used, the system requirements are incrementally developed in parallel with design and implementation.

2.11 Gathering Customer Requirements

In the mid-1980's managers began to recognize that being technology-driven –the practice of creating new technologies and then trying to find markets for them – was an inefficient approach to managing innovation and led to many failed efforts. As a result, momentum shifted to the customer-driven movement, which required managers to first understand what the customer wanted before investing in the creation of a new product or service. As part of this movement, managers sought needed inputs from customers and these inputs became known as “customer requirements”. As the process for getting these inputs evolved, it became popular –and is still today – to capture just what the customer says and to use that information as an input into the innovation process. This approach is often referred to as capturing the “voice-of-the-customer”. Logically, focusing on the “voice-of-the-customer” makes good sense, as it requires companies to listen closely to customers.

2.12 Engineering Management

Engineering managers oversee 4-P's people, projects, products, and processes. Overseeing manufacturing and production standards, working with creative engineers and generating technical documentation are just some of the responsibilities. Specialized knowledge and management practices geared toward the engineering environment help to enrich an engineering managers' toolbox to deal with the 4- P's with as much savvy as technical issues

2.13 Project Management

Tasks for the project were divided equally among the six team members. Modeling and Simulation was completed by Engr Chime and group A, and group B did design analysis while group C and group D managed the tasks and deadlines of the project. Many of the experiments were conducted with at least two members present and each team member was responsible for taking observations and developing design ideas. Online Regular team meetings were held to discuss the out-comings and progress of the project. A Henry Gantt chart can be found in Appendix A displaying the Individual task assignments and deadlines. This chart was used to guide the team and assure timely completion of the project. Each experiment provided insight for the project and so Gantt chart was updated regularly with new tasks to accomplish

2.14 Machine Descriptions and Operation

The palm kernel processing machine consists of five major units: the in-feed unit, the cracking unit, the discharge outlet, the sorting unit and the driven unit.

2.15 The In-Feed Unit

The feeding unit consists of the feed hopper and the in-feed elbow. The feed hopper design was largely influenced by the through put capacity required to make the performance of the machine satisfactory. The feed hopper is made in the shape of a frustum ($295 \times 86 \times 245\text{mm}$), and is inclined horizontally at an angle of 60° . This is to ensure free fall of the kernels through the hopper, to prevent jamming of kernels at the throat, and to make the feed hopper self-cleaning. However, the feed hopper itself is made of mild steel. The in-feed elbow is a half-parabolic tube which spans a total length of 20 inches, consisting of the hollow tube and the elbow itself. It is included in this design to prevent any form of back flow of kernels that may arise due to the sudden exposure of the kernels to the high speed of the impeller in the cracking chamber. More so, the in-feed elbow serves to present the fed kernels in such a way that each kernel is impacted by the impeller blades. The in-feed elbow

is slightly tilted to an angle of 10° to the horizontal to ensure that sufficient velocity is being built up by the free falling kernels along this route before their exposure to the high velocity cracking impeller, and to further reduce the risk of jamming at the entrance of the cracking chamber. This tilting also helps in improving the efficiency of the cracking chamber, and of the machine as a whole. The in-feed elbow also is made of mild steel.

2.6 The Cracking Unit

The cracking chamber, The cylinder measures 379×405 mm in its minor and major diameters respectively, and 179mm in its length. The cracking chamber is bored at a diameter of 85mm at the back surface to enable the passage of the driving shaft to the core of the chamber through the ball bearing. However, the core of the cracking chamber is characterized with the impeller tube and blades; the tube being the carriage for the rotary motion of the blades.

The cracking process is achieved by the impact force exerted on the kernels by the impeller blades against the walls of the cracking chamber. This impact force is generated by the kinetic energy of the impeller blades; the latter being facilitated by the high velocity rotary motion of the carriage tube on which the impeller blades are attached. Each kernel nut being fed to the cracking chamber is struck against the walls of the chamber by the high velocity impeller blades, thus creating sufficient impact force to loose each kernel seed from its shell covering. The cracking unit is also made of mild steel.

The discharge unit is situated directly below the cracking chamber. It is an opening of 186×105 mm in its widths and height axes respectively. The cracked nuts are transported to the sorting unit by the passage of the discharge unit. The discharge opening was designed to allow for the passage of multiple cracked nuts per time, thus preventing jam at the discharge, and hence enhancing better sorting efficiency.

2.17 The Sorting Unit

The sorting unit is made up of a rectangular metallic mesh with uniform rectangular grooves of diameter 10mm. This unit is directly attached to the nut outlet discharge of the cracking chamber, and it spans a total length of 400mm, width of 180mm, and height of 100mm. This unit operates in the form of an agitated basket, and is stimulated by the vibration effect from the electric motor; an action which buckles its rotation. The cracking chamber however, ensures that the shell coverings are effectively crushed to smaller particles compared to the

kernel seeds. This crushing ensures that the variation in size between the kernel seeds and the shells is large, hence the feasibility of the sieving-separation approach. More so, the diameter of the mesh grooves selected is smaller than the average kernel seed diameter (15mm), and this ensures that the kernel seeds are not ejected along the sorting route. Along the sorting route is a part referred to as a speed breaker. The speed breaker, A, functions to reduce the velocity of discharge of the nuts and shells from the cracking chamber, with a clearance of 20mm from the sorting tray, to ensure efficient sieve separation action along the sorting route.

Experimental observation proves that palm kernel seeds have a dynamic angle of repose of approximately 20° on mild steel; an angle which is lesser than the dynamic angle of repose of the shells on mild steel. This implies that the kernel seeds will develop a higher velocity coefficient along the slope, compared to their shell counterpart, and hence will avoid expulsion through the grooves. Therefore, the sorting tray is inclined at an angle of 20° to the horizontal, thus ensuring that the kernels seeds freely slide over the mesh grooves while the shells are properly expelled from the mesh grooves

2.18 The Driven Unit

The driven unit consists of the prime mover; the electric motor, the 2 two-way pulleys and the belt drive. The electric motor is rated 3hp, with the pulleys ranging in diameter sizes of 120mm to 80mm. The belt drive is a V-belt (A60) spanning through a length of 630mm.

2.19 Product Brand Design Management

The main focus of product brand management lies on the single product or product family. Product design management is linked to research and development, marketing, and brand management, and is present in the fast-moving consumer goods (FMCG) industry. It is responsible for the visual expressions of the individual product brand, with its diverse customer-brand touch points and the execution of the brand through design

2.20 Service Design Management

Service design management deals with the newly emerging field of service design. It is the activity of planning and organizing people, infrastructure, communication, and material components of a service. The aim is to improve the quality of the service, the interaction between the service provider and its customers, and the customer's experience. The increasing importance and size of the service sector in terms of people employed and economic

importance requires that services should be well-designed in order to remain competitive and to continue to attract customers. Design management traditionally focuses in the design and development of manufactured products; service design managers can apply many of the same theoretical and methodological approaches. Systematic and strategic management of service design helps the business gain competitive advantages and conquer new markets. Companies that proactively identify the interests of their customers and use this information to develop services that create good experiences for the customer will open up new and profitable business opportunities.

Companies in the service sector innovate by addressing the intangibility, heterogeneity, inseparability, and perishability of service challenge.

Services are intangible; they have no physical form and they cannot be seen before purchase or taken home.

Services are heterogeneous; unlike tangible products, no two service delivery experiences are alike.

Services are inseparable; the act of supplying a service is inseparable from the customer's act of consuming it.

Services are perishable; they cannot be inventoried. Service design management differs in several ways from product design management. For example, the application of international trading strategies of services is difficult because the evolution of service 'from a craftsmanship attitude to industrialization of services' requires the development of new tools, approaches, and policies. Whereas goods can be manufactured centrally and delivered around the globe, services have to be performed at the place of consumption, which makes it difficult to achieve global quality consistency and effective cost control.

2.21 Business Design Management

Business design management deals with the newly emerging field of integrating design thinking into management. In organisation and management theory, design thinking forms part of the Architecture / Design / Anthropology (A/D/A) paradigm which characterizes innovative, human-centered enterprises. This paradigm focuses on a collaborative and iterative style of work and an adductive mode of thinking, compared to practices associated with the more traditional Mathematics / Economics / Psychology (M/E/P) management paradigm. Since 2006, the term Business Design is trademarked by the Rotman School of Management; they define business design as the application of design thinking principles to

business practice. The designedly way of problem solving is an integrative way of thinking that is characterized by a deep understanding of the user, creative resolution of tensions, collaborative prototyping, and continuous modification and enhancement of ideas and solutions. This approach to problem solving can be applied to all components of business, and the management of the problem solving process forms the core of business design management activity. Universities other than the Rotman School of Management are offering similar academic education concepts, including the Aalto University in Finland, which initiated their International Design Business Management (IDBM) program in 1995.

Methodology

This involved the following processes -Design, Modelling, Simulation and the Sustainability of palm kernel cracking machine, below are the background of the project.

3.1 Computer Aided Design(CAD)

CAD began as an electronic drafting board, a replacement of the traditional paper and pencil drafting method. Over the years it has evolved into a sophisticated surface and solid modeling tool. Not only can products be represented precisely as solid models, factory shop floors can also be modeled and simulated in 3D. It is an indispensable tool to modern engineers. Engineers use CAD to create two- and three- dimensional drawings, such as those for automobile and airplane parts, floor plans, and maps and machine assembly. While it may be faster for an engineer to create an initial drawing by hand, it is much more efficient to change and adjust drawings by computer. In the design stage, drafting and computer graphics techniques are combined to produce models of different parts. i. Using compute to perform the six-step 'art-to-part' process: The first two steps in this process are the use of sketching software to capture the initial design ideas and to produce accurate engineering drawings. Next, engineers use analysis software to ensure that the part is strong enough. Step five is the production of a prototype, or model. In the final step the CAM software controls the machine that produces the part, during the design of the machine and the drafting, software was used to draw the orthogonal views shown in figures 1-36

3.2 Product Design Management

In product-focused companies, design management focuses mainly on product design management, including strong interactions with product design, product marketing, research and development, and new product development. This perspective of design management is mainly focused on the aesthetic, semiotic, and ergonomic aspects of the product to express

the product's qualities and to manage diverse product groups and product design platforms and can be applied together with a user-centered design perspective.

3.3 Modeling

Modeling is the process of producing a model; a model is a representation of the construction and working of some system of interest. A model is similar to but simpler than the system it represents. One purpose of a model is to enable the analyst to predict the effect of changes to the system. On the one hand, a model should be a close approximation to the real system and incorporate most of its salient features. On the other hand, it should not be so complex that it is impossible to understand and experiment with it. A good model is an astute interchange between realism and simplicity. Simulation practitioners recommend increasing the complexity of a model iteratively. An important issue in modeling is model validity. Model validation techniques include simulating the model under known input conditions and comparing model output with system output. Generally, a model intended for a simulation study is a mathematical model developed with the help of simulation software. Mathematical model classifications include deterministic (input and output variables are fixed values) or stochastic (at least one of the input or output variables is probabilistic); static (time is not taken into account) or dynamic (time-varying interactions among variables are taken into account). Typically, simulation models are stochastic and dynamic shown in figure 2, figure10, etc.

3.4 Simulation

Simulation technology can provide a highly effective means for evaluating the design of a new manufacturing system or proposed modifications to existing systems. This technology can be especially useful in supporting agility, sustainability, supply chain integration, as well as the development of new advanced processes. Manufacturing simulations are often used as measurement tools that predict the behavior and performance of systems that have not yet been implemented, or to determine theoretical capabilities of existing systems. Simulations are essentially experiments. As defined in Jerry Banks Handbook of Simulation, a simulation is: "...the imitation of the operation of a real world process or system over time. Simulation involves the generation of an artificial history of the system and the observation of that artificial history to draw inferences concerning the operational characteristics of the real system that is represented. Simulation is an indispensable problem-solving methodology for the solution of many real-world problems. Simulation is used to describe and analyze the

behavior of a system, ask what-if questions about the real system, and aid in the design of real illustrated in Figure 8- Figure 34

3.5 Sustainability

Simulation technology has been a significant tool for improving manufacturing operations in the past; but its focus has been on lowering costs, improving productivity and quality, and reducing time to market for new products. Sustainable manufacturing includes the integration of processes, decision-making and the environmental concerns of an active industrial system to achieve economic growth, without destroying precious resources or the environment. Sustainability applies to the entire life cycle of a product. It involves selection of materials, extraction of those materials, of parts, assembly methods, retailing, product use, recycling, recovery, and disposal will need to occur if simulation is to be applied successfully to sustainability. Manufacturers will need to focus on issues that they have not been concerned with before, engineering specifications, and then designing component illustrated in figure 36 and table 3-4.

3.6 Wire Frame

The most basic functions of CAD are the 2D drafting functions. 2D geometry such as line, circles, and curves can be defined. A 2D profile can also be extruded into a 2 1/2 D object. The extruded object is a wireframe of the object CAD also allows a 3D wire-frame to be defined illustrated in Figure;7. To cover the wire-frame model, faces can be added to the model. This creates a shell of the object. Hidden line/surface algorithms can be applied to create realistic pictures. Many menu functions are used to help simplify the design process. Annotation and dimensioning are also supported. Text and dimension symbols can be placed anywhere on the drawing, at any angle, and at any size

3.8 Discretization Meshing Coarse

Faster computation; not concerned about stress concentrations, singularities, or warping. Not near changes in geometry or displacement constraints or changes in material including thickness.

3.9 Meshing Fine

Best approximation but at the cost of the computation time. Look for disproportionate stress level changes from node to node or plate to plate and large adjacent node displacement differences to determine if need to refine the mesh. Nodes should be defined at locations

where changes of geometry or loading occur. Changes in geometry relate to thickness, material and/or curvature. A simple check, if you can, is to decrease the mesh size by 50%, re-run analysis, and compare the change of magnitude of stresses and strains. If there is no significant change, then ok. In most companies, all of this knowledge of mesh size will be known and might be set a FEA control file illustrated in Figure;10.

3.10 Basic Theory

The way finite element analysis obtains the temperatures, stresses, flows, or other desired unknown parameters in the finite element model are by minimizing an energy functional. An energy functional consists of all the energies associated with the particular finite element model. Based on the law of conservation of energy, the finite element energy functional must equal zero. The finite element method obtains the correct solution for any finite element model by minimizing the energy functional. The minimum of the functional is found by setting the derivative of the with respect to the unknown grid point potential for zero.

3.11 Finite Element Analysis

Finite element analysis (FEA) is a computerized analysis method to envisage how a manufactured product will react to the physical world. The analysis includes bringing the product in contact with force, heat, vibration, fluid flow and other such physical conditions. The FEA can predict if the product is likely to break, tear, wear or behave the way it is manufactured to First developed in 1943 by R. Courant, finite element analysis is a part of the manufacturing process in order to help predict how an object would react to real-world conditions when used. FEA also helps solid-state scientists to improve the quality and function of an object. FEA essentially computes the individual component behavior and sums it up to predict the overall behavior of the manufactured product. FEA now commonly uses computers to model the object, which is then stressed and analyzed to obtain desired results. In the case of a faulty product or undesired result, FEA can help create a new design to meet the necessary conditions.

A typical finite element analysis on a software system requires the following information Nodal point spatial locations (geometry) Elements connecting the nodal points, Mass properties, Boundary conditions or restraints, Loading or forcing function details, Analysis options. Shown in figur, 9, figure10 etc table1- 2.

3.12 Developing Simulation Models

Simulation models consist of the following components: system entities, input variables,

performance measures, and functional relationships. Following are the steps to develop a simulation model.

Step 1: Identify the problem with an existing system or set requirements of a proposed system.

Step 2: Design the problem while taking care of the existing system factors and limitations.

Step 3: Collect and start processing the system data, observing its performance and result.

Step 4: Develop the model using network diagrams and verify it using various verifications techniques

Step 5: Validate the model by comparing its performance under various conditions with the real system.

Step 6: Create a document of the model for future use, which includes objectives, assumptions, input variables and performance in detail.

Step 7: Select an appropriate experimental design as per requirement.

Step 8: Induce experimental conditions on the model and observe the result.

Cad/ Views and Analysis of Machine

Figure 1 Published Drawing

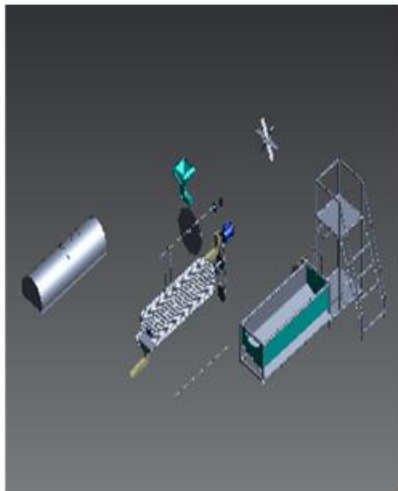

Figure 2 CAD Drawing

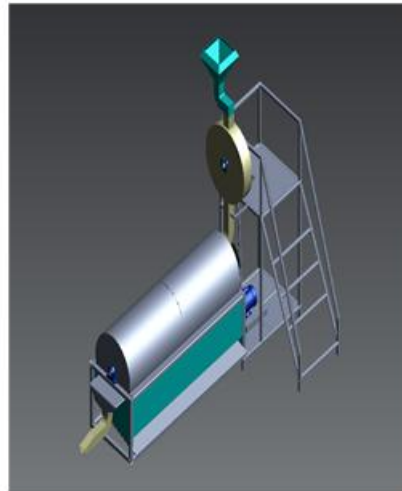

Figure 3 Multiply Views

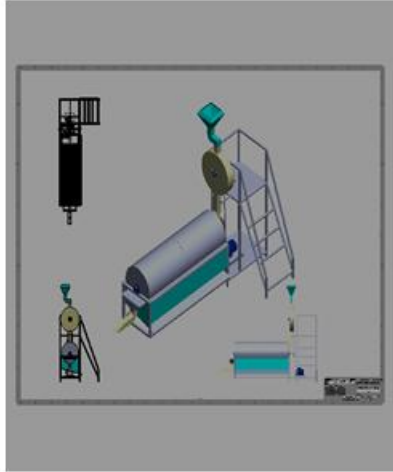

Figure 4 Isometric Drawing

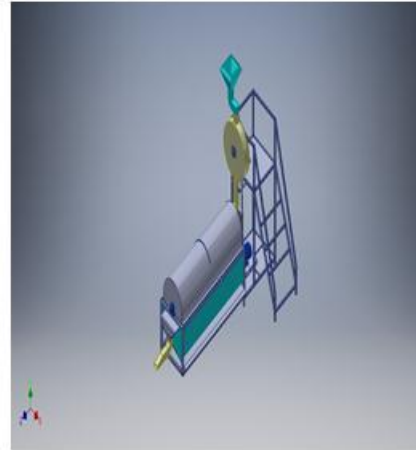

Figure 5 Wire Frame



Figure 6 explode view

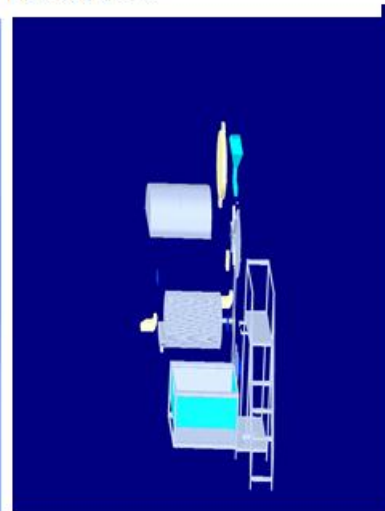

Figure 7 Machine Component

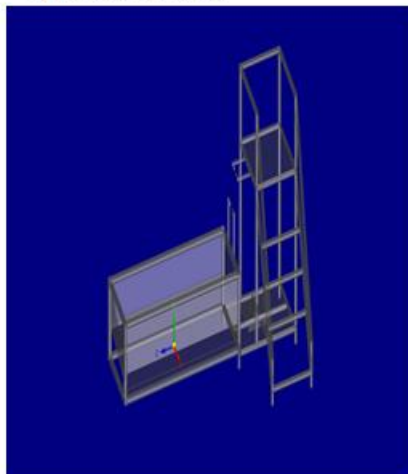

Figure 8 apply constrain

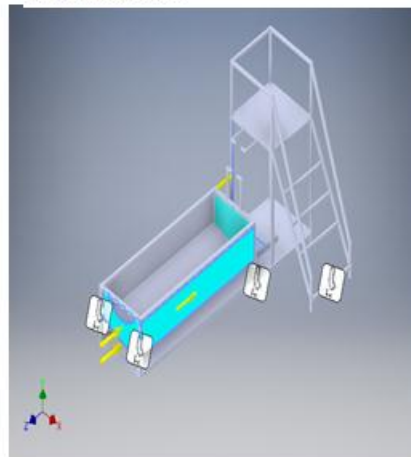

Table 1: Force, Mesh Material and Reaction Force.**Physical**

Material	Generic
Density	0.0361273 lbmass/in ³
Mass	131.67 lbmass
Area	15234200 mm ²
Volume	59724400 mm ³
Center of Gravity	x=-269.602 mm y=102.229 mm z=-766.26 mm

Force 1:

Load Type	Force
Magnitude	2000.000 lbforce
Vector X	0.000 lbforce
Vector Y	0.000 lbforce
Vector Z	-2000.000 lbforce

Force 2:

Load Type	Force
Magnitude	2000.000 lbforce
Vector X	-0.000 lbforce
Vector Y	-0.000 lbforce
Vector Z	-2000.000 lbforce

Mesh settings

Avg. Element Size (fraction of model diameter)	0.1
Min. Element Size (fraction of avg. size)	0.2
Grading Factor	1.5
Max. Turn Angle	60 deg
Create Curved Mesh Elements	Yes

Material(s)

Name	Nylon, molybdenum disulphide	
General	Mass Density	0.0408238 lbmass/in ³
	Yield Strength	12001.9 psi
	Ultimate Tensile Strength	11991.7 psi
Stress	Young's Modulus	424.961 ksi
	Poisson's Ratio	0.35 ul

	Shear Modulus	157.393 ksi
Part Name(s)	PKSH1_Default_As Machined_	

Reaction Force and Moment on Constraints

Constraint Name	Reaction Force		Reaction Moment	
	Magnitude	Component(X,Y,Z)	Magnitude	Component(X,Y,Z)
Fixed Constraint:1	4000 lbforce	0 lbforce	2786.73 lbforce ft	1044.96 lbforce ft

Force 2:

Load Type	Force
Magnitude	2000.000 lbforce
Vector X	-0.000 lbforce
Vector Y	-0.000 lbforce
Vector Z	-2000.000 lbforce

Figure 9, Von Mises Stress 454.4 max

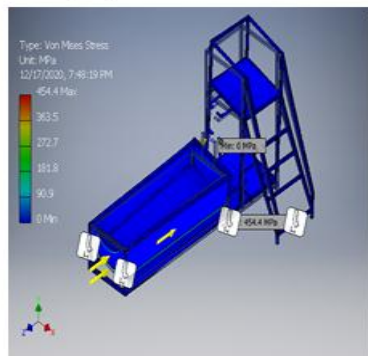

Figure 10 1st Principal Stress

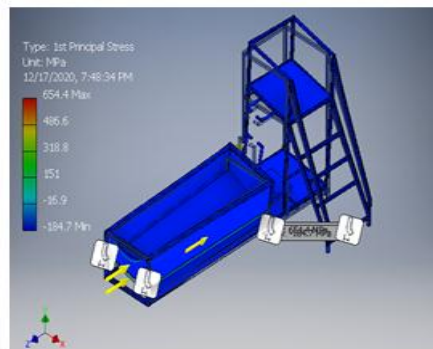

Figure 11 3rd Principal Stress

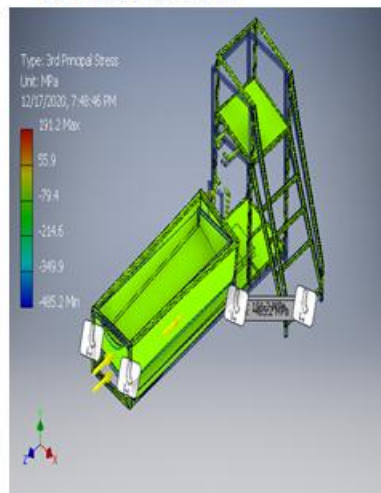

Figure 12. Displacement

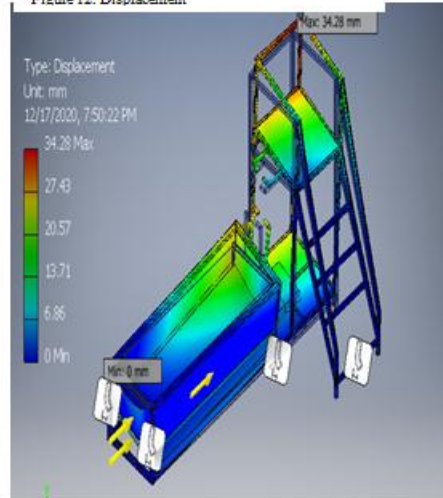

Figure 13 Safety Factor

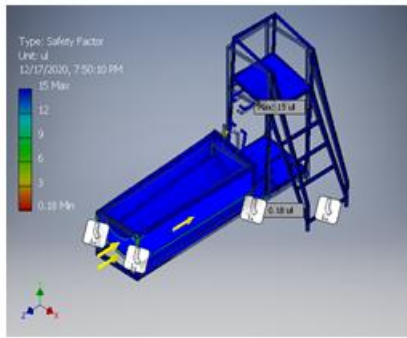

Figure 14 Stress XX

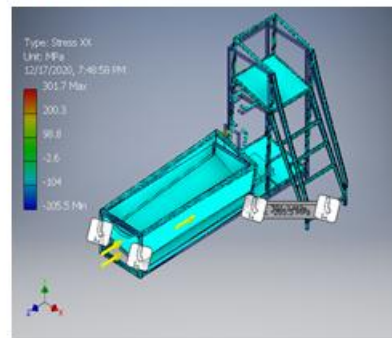

Figure 15: Stress YY

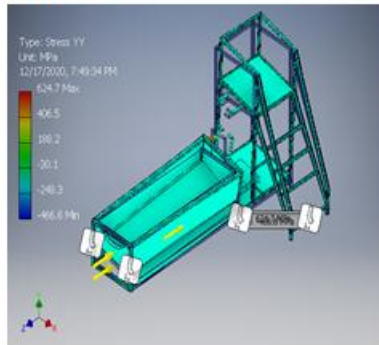

Figure 16 Stress YZ

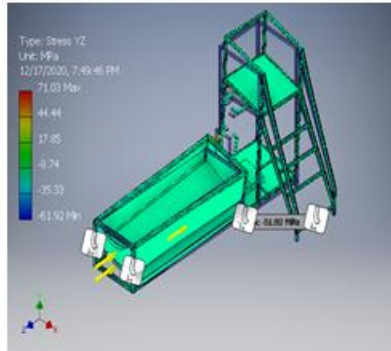

Figure.17 Stress ZZ

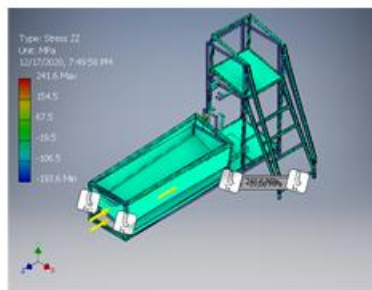

Figure 18 X Displacement

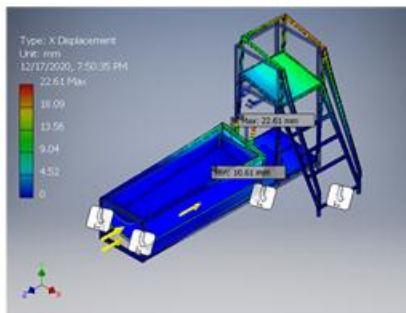
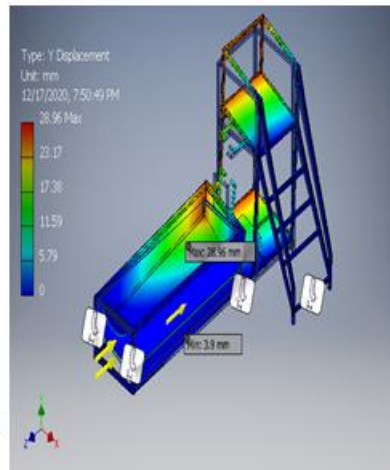
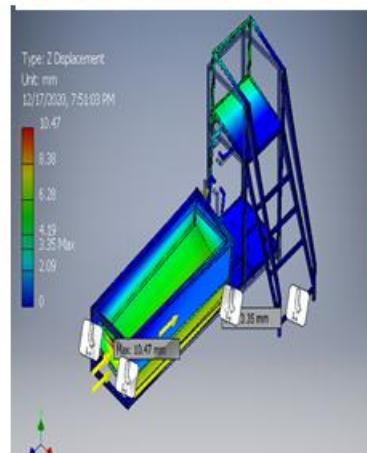

Figure 19 Y Displacement



Figure; 20 Z Displacement



Figure,21 Equivalent Strain

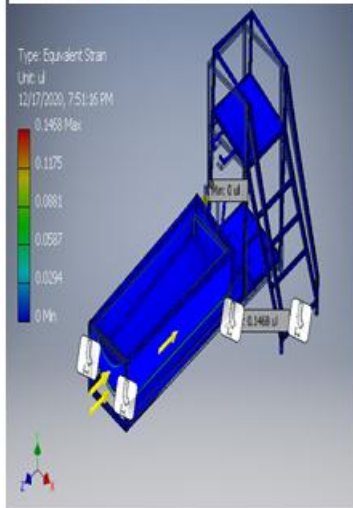
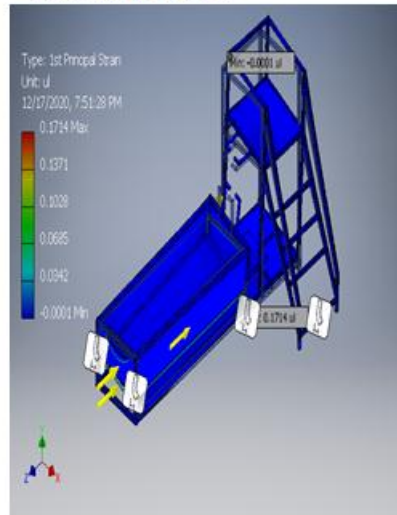
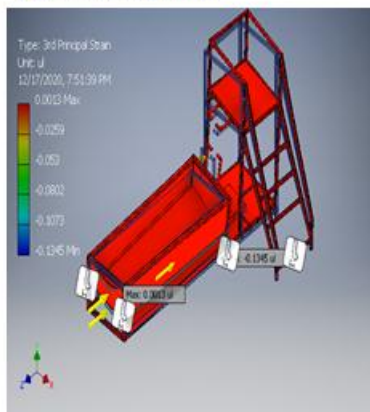

Figure 22 1st Principal Strain



Figure, 23 3rd Principal Strains



Figure; 24, Strain XX

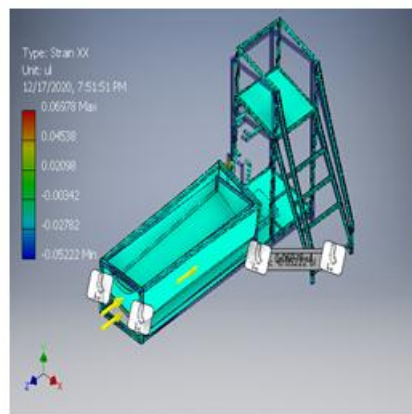

Figure 25. Strain XY

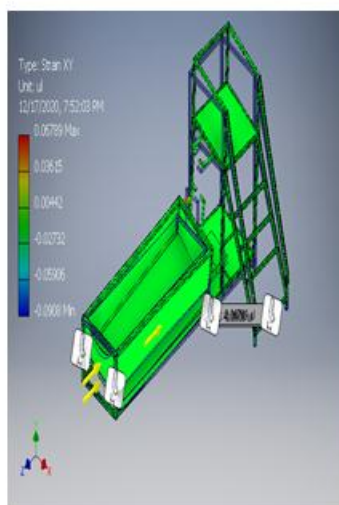
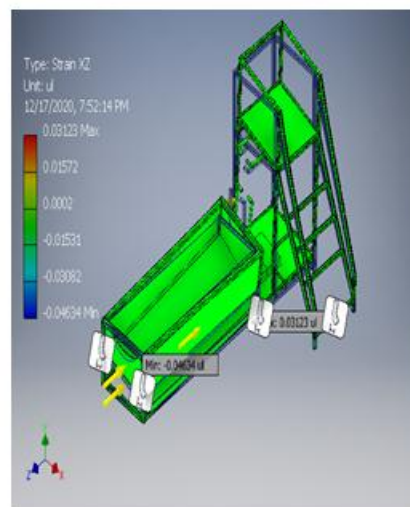

Figure 26. Strain XZ



Figure; 27 Strain YY

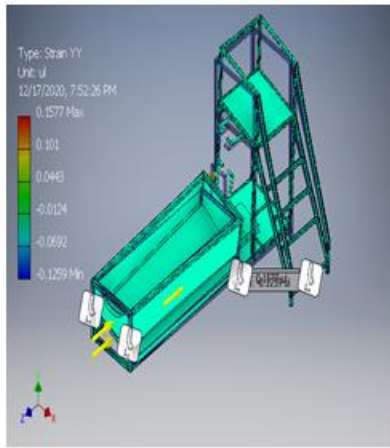
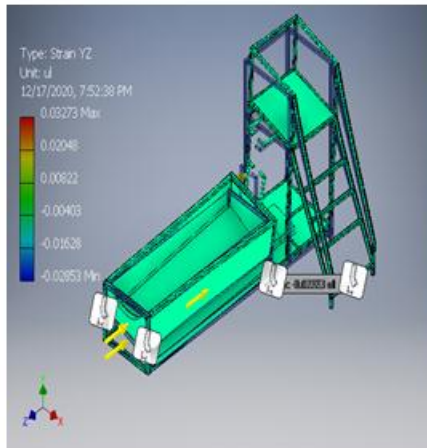
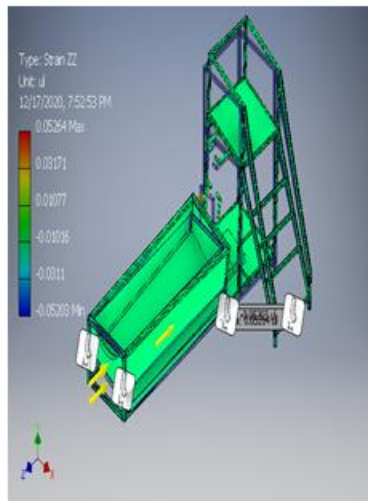

Figure 28 Strain YZ



Figure; 29 Strain ZZ



Figure; 30 Contact Pressure

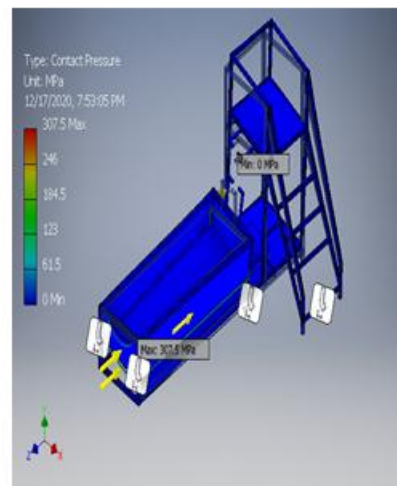

Figure 31 Contact Pressure X

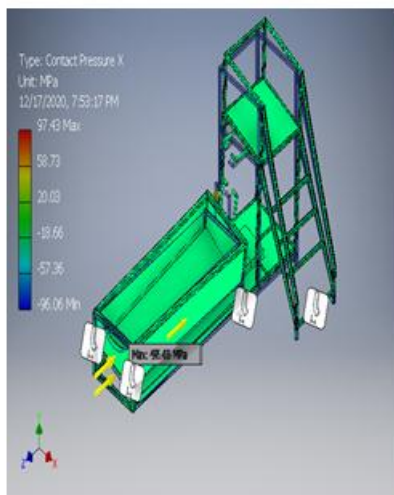
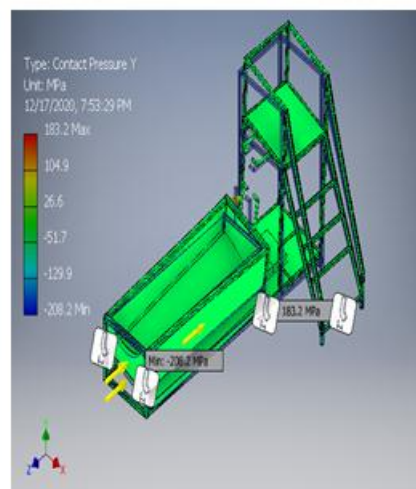
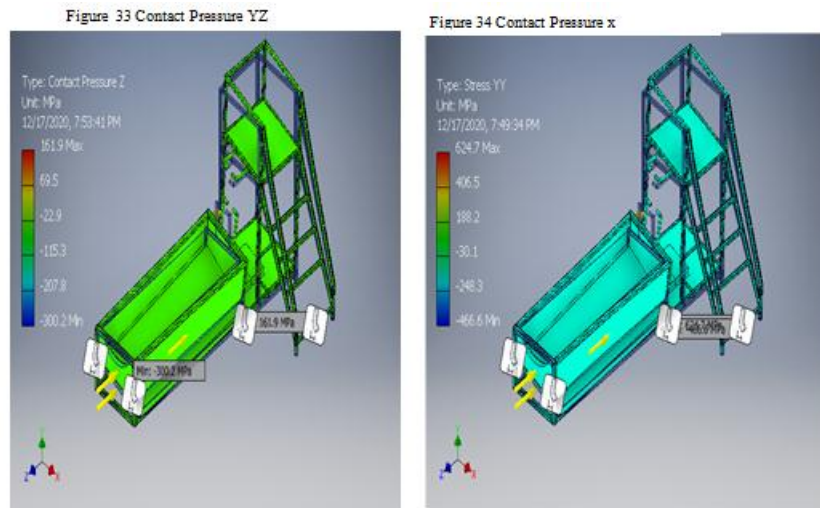

Figure 32 Contact Pressure Y





Performing Simulation Analysis

Following are the steps to perform in simulation analysis.

Step 1: Prepare a problem statement.

Step 2: Choose input variables and create entities for the simulation process. There are two types of variables - decision variables and uncontrollable variables. Decision variables are controlled by the programmer, whereas uncontrollable variables are the random variables.

Step 3: Create constraints on the decision variables by assigning it to the simulation process.

Step 4: Determine the output variables.

Step 5: Collect data from the real-life system to input into the simulation.

Step 6: Develop a flowchart showing the progress of the simulation process.

Step 7: Choose an appropriate simulation software to run the model.

Step 8: Verify the simulation model by comparing its result with the real-time system.

Step 9: Perform an experiment on the model by changing the variable values to find the best solution.

Step 10: Finally, apply these results into the real-time system

We have done the following static analysis of the component, the result is presented below

4.2 Applying Constraints

After you define your loads, you must specify the constraints on the geometry of the part. You can apply as many constraints as you need. The defined constraints are listed in the browser under Loads & Constraints. After you define a constraint, you can edit it by right-clicking it, and then selecting Edit from the menu

4.3 Interpreting Results Contours

The contour colors displayed in the results correspond to the value ranges shown in the legend. In most cases, results displayed in red are of most interest, either because of their representation of high stress or high deformation, or a low factor of safety. Each results set gives you different information about the effect of the load on your part

4.4 Equivalent Stress

Equivalent stress results use color contours to show you the stresses calculated during the solution for your model. The deformed model is displayed. The color contours correspond to the values defined by the color bar.

4.5 Maximum Principal Stress

The maximum principal stress gives you the value of stress that is normal to the plane in which the shear stress is zero. The maximum principal stress helps you understand the maximum tensile stress induced in the part due to the loading conditions.

Minimum Principal Stress

The minimum principal stress acts normal to the plane in which shear stress is zero. It helps you understand the maximum compressive stress induced in the part due to the loading conditions.

4.7 Deformation

The deformation results show you the deformed shape of your model after the solution. The color contours show you the magnitude of deformation from the original shape. The color contours correspond to the values defined by the color bar.

4.8 Safety Factor

Safety factor shows you the areas of the model that are likely to fail under load. The color contours correspond to the values defined by the color bar.

4.9 Frequency Modes

You can view the mode plots for the number of resonant frequencies that you specified in the solution. The modal results appear under the Modes folder in the browser. When you double-click a frequency mode, the mode shape is displayed. The contours show you the color magnitude of deformation from the original shape. The frequency of the mode is shown in the legend. It is also available as a parameter

Mesh Information

Table 2: Mesh Information. Thermal Results Displacement, Stress Result Etc.

Mesh type	Tetrahedral
Total number of bodies meshed	1
Total number of elements	273
Total number of nodes	658
Subjective mesh size (1-10)	3

Thermal Results

Result component: Temperature				
Extent	Value	X	Y	Z
Minimum	20 C	12.000 mm	263.690 mm	-990.000 mm
Maximum	21 C	12.000 mm	263.690 mm	-990.000 mm

Displacement Results

Result component: Total Translation				
Extent	Value	X	Y	Z
Minimum	0 mm	12.000 mm	263.690 mm	-990.000 mm
Maximum	0.000407 mm	2.000 mm	263.690 mm	740.000 mm

Stress Results

Result component: Von Mises				
Extent	Value	X	Y	Z
Minimum	3.46 MegaPa	2.000 mm	263.690 mm	740.000 mm
Maximum	7.11 MegaPa	12.000 mm	263.690 mm	-990.000 mm

Factor of Safety Results

Result Component: Factor of Safety				
Extent	Value	X	Y	Z
Minimum	35.9	12.000 mm	263.690 mm	-990.000 mm
Maximum	73.7	2.000 mm	263.690 mm	740.000 mm

Result Summary

Name	Minimum	Maximum
Volume	59724400 mm ³	
Mass	148.787 lbmass	
Von Mises Stress	0.0000628428 MPa	454.419 MPa
1st Principal Stress	-184.677 MPa	654.395 MPa
3rd Principal Stress	-485.211 MPa	191.218 MPa
Displacement	0 mm	34.2846 mm
Safety Factor	0.182101 ul	15 ul
Stress XX	-205.467 MPa	301.708 MPa

Stress XY	-197.064 MPa	147.349 MPa
Stress XZ	-100.571 MPa	67.7816 MPa
Stress YY	-466.591 MPa	624.747 MPa
Stress YZ	-61.9201 MPa	71.0281 MPa
Stress ZZ	-193.558 MPa	241.564 MPa
X Displacement	-10.6084 mm	22.6078 mm
Y Displacement	-3.90041 mm	28.9644 mm
Z Displacement	-10.4717 mm	3.34691 mm
Equivalent Strain	0.0000000235414 ul	0.146844 ul
1st Principal Strain	-0.0000661975 ul	0.171357 ul
3rd Principal Strain	-0.13445 ul	0.00127085 ul
Strain XX	-0.0522158 ul	0.0697844 ul
Strain XY	-0.0907976 ul	0.0678911 ul
Strain XZ	-0.0463384 ul	0.0312304 ul
Strain YY	-0.125871 ul	0.157696 ul
Strain YZ	-0.0285298 ul	0.0327263 ul
Strain ZZ	-0.0520328 ul	0.0526439 ul
Contact Pressure	0 MPa	307.501 Mpa

Contact Pressure X	-96.0621 MPa	97.4327MPa
Contact Pressure Y	-208.226 MPa	183.161MPa
Contact Pressure Z	-300.173 MPa	161.887MPa

4.10 Sustainability Result

Sustainability” is increasingly on corporate agendas. While social and environmental responsibility is often at the root of such efforts, many companies are also finding that sustainable design is just “good business.” Through it, companies find new ways to decrease material and energy costs, and increase revenue through resulting new product innovations. Sustainable development is development that meets the needs of the present without compromising the ability of future generations to meet their own need.

4.11 Energy Consumption

A measure of the non-renewable energy sources associated with the part’s life cycle in nits of mega joules (MJ). This impact includes not only the electricity or fuels used during the product’s life cycle, but also the upstream energy required to obtain and process these fuels, and the embodied energy of materials which would be released if burned. Energy Consumed is expressed as the net calorific value or energy demand from non-renewable resources (e.g.

petroleum, natural gas, etc.). Efficiencies in energy conversion (e.g. power, heat, steam, etc.) are taken into account.

Air Acidification Sulfur dioxide, nitrous oxides other acidic emissions to air cause an increase in the acidity of rain water, which in turn acidifies lakes and soil. These acids can make the land and water toxic for plants and aquatic life. Acid rain can also slowly dissolve man-made building materials such as concrete. This impact is typically measured in nits of either kg sulfur dioxide equivalent (SO_2e), or moles H^+ equivalent.

4.12 Water Eutrophication

When an overabundance of nutrients is added to a water ecosystem, eutrophication occurs. nitrogen and phosphorous from waste water and agricultural fertilizers causes an overabundance of algae to bloom, which then depletes the water of oxygen and results in the death of both plant and animal life. This impact is typically measured in either kg phosphate equivalent (PO_4e) or kg nitrogen (N) equivalent.

4.13 Color Coding

When Baseline is clicked, the environmental impacts turn colors to represent different states.

Black represents the baseline material.

Green indicates that the current material is more environmentally friendly than the baseline material.

Red indicates that the current material is less environmentally friendly than the baseline material.

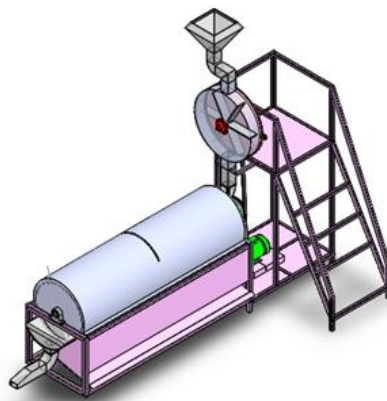

Figure 36: Sustainability Analysis Result.

Table 3: Sustainability Analysis Report.

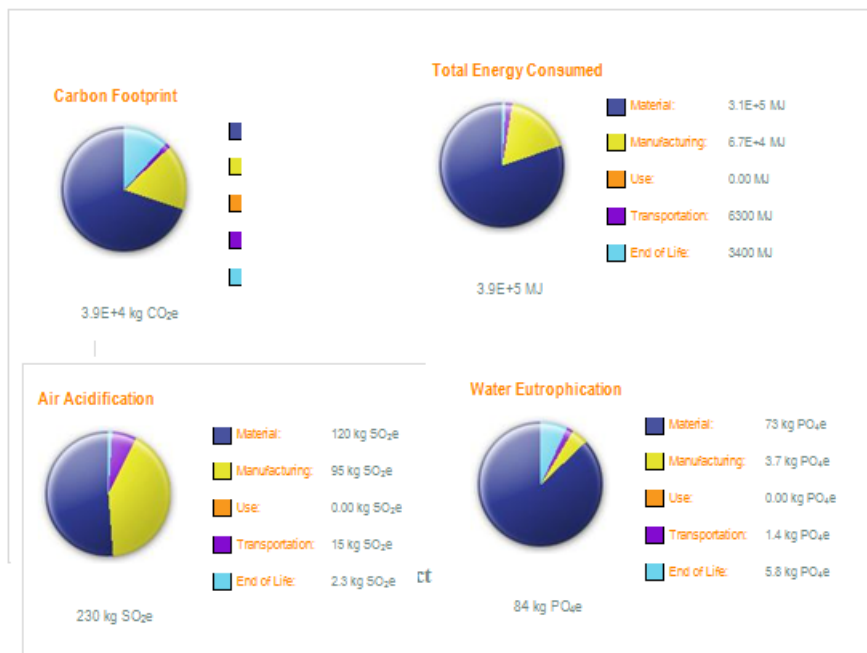

Table 4: Component Environmental Impact.

PKSH1_Default<As Machined>.STEP	3000	10	16	3.2E+4
PKSH10.1.STEP	870	3.3	5.4	9800
5990K123_BASE-MOUNT AC MOTOR.STEP	170	0.583	0.938	1900
PKSH14.STEP	82	0.064	0.499	950
PKSH18.STEP	78	0.036	0.497	930
PKSH8.STEP	56	0.026	0.359	670
PKSH15.STEP	37	0.017	0.236	440
PKSH19.STEP	28	0.013	0.180	330
PKSH17.STEP	21	0.069	0.111	220
PKSH12.STEP	23	0.011	0.149	280

4.14 DISCUSSION

It is general knowledge that those who are engaged in agriculture are the poor in comparison with those who engaged in other sector of the economy in Nigeria that is to say their standard of living is so low that shortage of funds to enable them purchase facilities has been a major handicap in the development. Investigation shows that the few available small scale

processing equipment are not very efficient. This lack of efficiency small scale processing equipment to farmers has increased the inability of their farming activities. Agricultural productivity is measured as the ratio of agricultural outputs to agricultural inputs. While individual products are usually measured by weight, their varying densities make measuring overall agricultural output difficult. Therefore, output is usually measured as the market value of final output, which excludes intermediate products such as corn feed used in the meat industry. Simulation tools enable us to be creative and to quickly test new ideas that would be much more difficult, time consuming, and expensive to test in the lab. (Jeffrey D. Wilson, Nasa Glenn Research Center) It also help us reduce cost and time-to-market by testing our designs on the computer rather than in the field.

With the rapid pace of technological innovations, it's no surprise that speed to market usually wins. Your whole design process needs to be fluid and all the tools you use should allow you to move fast. Creating the initial design is the easy part. The design tools you choose should allow you to quickly create multiple design iterations so that you can find the right balance to achieve the desired form, fit and function. You should be able to pivot fast when you hit design issues. Therefore, make sure the tools that you select don't constrain you, but instead are very flexible to design changes. Technologies looking for a problem to solve have a very high probability to fail. Product designers need to solve problems that customers care about and are willing to pay to resolve.

The success of a consumer product heavily depends on how well you as a product designer know your target customers. Given the plethora of tools and technologies that are available, it is very tempting to start your product design using CAD. However, this approach will backfire and result in wasted time, money and resources if you don't deeply understand your customers' needs first.

Any development process, software or hardware, goes through numerous stages. Right from conceptualization to the stage where it reaches the hands of the consumer, a product goes through many stages - design, analysis, manufacturing and so on. Each process not only adds value but also contributes to the cost of the product. However, the price of the product is not entirely in the control of the producer. In a competitive environment, the price is determined by the "market". Hence, all organizations take definitive steps to keep the production and development costs of the product under control. In such a competitive environment, any rework is taboo and the later in the product life cycle any rework has to be done, the more it

costs. If any design flaws are detected during manufacture, it costs the organization time and money to correct the same. If such flaws are detected during operation at the customer site, it dents the reputation of the producing organization.

To avoid such scenarios, organizations apply review mechanisms for critical steps in the development and production steps of a product. Design reviews are intended to catch any issues at the earliest since rectifying a defect later in the cycle drastically increases the cost of the fix. In some cases, for example between a vendor and a customer, reviews are conducted to reconfirm the specifications and the progress made in a delivery.

Traditionally, reviews between vendor and customer included face-to-face meetings to confirm the solution provided and the associated cost. Within organizations, review mechanisms would include comments on the drawing prints. With the introduction of CAD, email and the web, comments were now added to drawing snapshot images and added to an email trail. It is not easy to communicate technical details in 2D. However, due to confidentiality issues and the size of the CAD data, sharing of these files for reviews were not a feasible option. The required collaboration for conducting.

CONCLUSION

Manufacturers need to consider moving from single manufacturing to dual manufacturing: manufacturing physical and virtual products.

Simulation is an important and useful technique that can help users understand and model real life systems. Once built, the models can be run to give realistic results. This provides a valuable support in making decisions on a more logical and scientific basis. Simulation has been one of prime methods used as a decision support tool in industry. It is a powerful tool for designing and analyzing complex and dynamic systems to predict their behavior under different conditions on a time scale. Simulation is a highly cost-effective method of testing new processes without having to carry out actual experiments. This can save enormous amounts of money, which would otherwise be spent on pilot programs, yet can produce.

Thus the nation's oil palm industry is still subsistent with very few large estate plantations that make large mills and imported mills relatively expensive and affordability by most farmers, thereby making the traditional method to predominate.

Though the technology of palm oil production has advanced in recent years with new

technological innovation to produce palm oil, survey results showed that 80 percent of Nigerians oil palm resource exist in smallholders. Computers function in the design process through geometric modeling capabilities, engineering analysis calculations, testing procedures, and automated drafting, from the result of testing and affordability in term of cost, it can be concluded that the project is successful

RECOMMENDATIONS

Develop guidelines for accuracy, precision and transparency in simulations and models to ensure high-quality products. (“If you can’t measure it, you can’t manage it.”) Develop standards, regulations and guidelines to promote high quality, accurate data in models and simulations to help determine the risk, cost and inherent problems in product development Create economic stimuli, tax breaks and government funding to make modeling and simulation affordable to small manufacturers. Develop a standard, consistent interface that contains certain concepts regardless of the tool (such as the cut/paste feature in all word processing programs). Promote standards for building and validating models, including a focus on best practices and harmonization. Provide funding for research projects that can have important ramifications for small businesses, which, alone, are unable to make such investments.

Challenges and Recommendations for Creating and Using Models and Simulations

Government

More research and development are needed to develop pilot programs in simulation and modeling to support the manufacturing processes.

Accessibility of modeling and simulations to small manufacturers is limited because of high costs. Developing sophisticated models, simulations and creating virtual designs often depends on accurate, high quality and precise data and validation, which are lacking. How something is modeled is not always transparent to the user.

Further work

Steps are being taken to increase the efficiency of the Machine also to manufacture physical product based on all the experiments conducted so far in this project. Prototype of the system will be fabricated for the validation of the simulation results on a physical hardware

REFERENCE

1. Adzimah S. K. and Seckley E. Modification in the design of an already existing palm nut - fibre separator, *African Journal of Environmental Science and Technology*, 2009; 3(11): 387-399.
2. Asuquo, J. E., Anusiem, A. C. I. and Etim, E. E. Extraction and characterization of Shea butter oil. *World journal of Applied Science and Technology*, 2010; 2(2): 282-286.
3. Awada et al <http://www.nature.com/bjc/journal/v95/n5/full/6603291a.html>, 2005.
4. Barry Lawson Associates Peacham, Vermont Challenges to Innovation in Advanced Manufacturing: Industry Drivers and R&D Needs by the Manufacturing Engineering Laboratory National Institute of Standards and Technology Gaithersburg, Maryland November, 2010; 3-4: 2009.
5. Bürdek, Bernhard E. *Design – Geschichte, Theorie und Praxis in der Produktgestaltung* (3rd ed.). Berlin: Birkhäuser – Verlag für Architektur 358ff. ISBN 3-7643-7028-9, 2005.
6. Buchanan, L., "From Cheap to WOW", Case Study, Thunderbird School of Global Management, 2005.
7. Chime Ogbuka, Rufus et al [2015] Improving Productivity in Feed Mixing Machine Manufacturing In Nigeria by *International Journal of Scientific & Engineering Research*, October-2015; 6(10). ISSN 2229-5518.
8. Chime Ogbuka, Rufus et al Design, Modelling And Simulation Of A Palm Kernel Oil Extraction Machine Management Approach By *International Journal of Advancements in Research & Technology*, 2015; 4(10). October -2015 62 ISSN 2278-7763.
9. Chime Ogbuka, Rufus *Designing for Sheet Metal Fabrication of Cocoa Depositing and Winnowing Machine* <https://www.casestudiesjournal.com>, 2020.
10. Chime Ogbuka, Rufus, Ogbeide S.O Computer Simulation in Palm Kernel Cracking Machine Design by *ICONIC Research and Engineering* Chime Ogbuka, Rufus (2020) *Manufacturing Cost Analysis of Automated Paper Making Machine Design Innovation International Journal of Engineering Sciences Research Technology* www.ijesrt.com©, 2019.
11. Chime Ogbuka, Rufus *Eco Innovation; Computer Simulation in Cassava Grating Machine* www.wjert.org.
12. Chime Ogbuka, Rufus, F.O. Odo Analysis of Garri Frying Machine Manufacturing in Nigeria: Design Innovation published by *Advances in Science, Technology and Engineering Systems Journal*, 2018; 3(6): 403-411. www.astesj.com.
13. Chime Ogbuka, Rufus **Ugwu. B.N, Arokwu F.N** Design Innovation in Metal Fabrication of Industrial PalmFruit Bunch Stripper Analysis by [://www.casestudiesjournal.com/](http://www.casestudiesjournal.com/), 2020.

14. Chime Ogbuka, Rufus et al Innovation In A Water Well Potable Drilling Machine Design Analysis by BEST: International Journal of Management Information Technology and Engineering (BEST: IJMITE) www.bestjournals.in, 2020.
15. Chime Ogbuka, Rufus Sustainable Design In Palm Fruit Bunch Stripper Manufacturing *International Journal of Contemporary Applied Researches*, 2019; 6(11). (ISSN: 2308-1365).
16. Chime Ogbuka, Rufus et al Analysis of Garri Frying Machine Manufacturing in Nigeria: Design Innovation published by *Advances in Science, Technology and Engineering Systems Journal*, 2018; 3(6): 403-411 www.astesj.com.
17. Chime Ogbuka, Rufus Manufacturing Simulation of Cassava Chipping Machine Design Analysis Published by *Journal of Emerging Trends in Engineering and Applied Sciences (JETEAS)*, 2018; 9(4): 176-185. © Scholarlink Research Institute Journals, 2018 (ISSN: 2141-7016) Journal of Emerging Trend.
18. Chiva, Ricardo; Alegre, Joaquín (July). "Investment in Design and Firm Performance: The Mediating Role of Design Management". *Journal of Product Innovation Management*. Wiley-Blackwell, 2009; 26(4): 424–440(17). doi:10.1111/j.15405885.2009.00669.x (<https://doi.org/10.1111%2Fj.15405885.2009.00669.x>).
19. Design Management Institute. Summer, 1993.
20. Design Management Institute. "Design Management Definition".
21. (http://www.dmi.org/dmi/html/aboutdmi/design_management.htm). Design Management Institute. Retrieved April 24, 2010.
22. Design Council. "Design Fact Finder" (<https://web.archive.org/web/20100811075214/http://www.designfactfinder.co.uk/>) Design Council. Archived from the original (<http://www.designfactfinder.co.uk/>) on 11 August 2010. Retrieved 23 January 2011.
23. De Mozota, Brigitte Borja "Design and competitive edge: A model for design management excellence in European SMEs" (<http://dmi.org>). *Design Management Journal*. Boston: Design Management Institute. 2 (Academic Review), 2003.
24. Design Management Institute "18 Views on the Definition of Design Management" (<http://www.dmi.org>). *Design Management Journal*. Design Management Institute, 1996; 9 (3): 14–19.
25. Retrieved February. Check date values in: `|accessdate= (help)`, 2000.
26. Emmitt, S., & Ruikar, K. *Collaborative design management*. London: Routledg, 2013.
27. EU study. "The economy of culture in Europe" (http://ec.europa.eu/culture/key-documents/doc873_en.htm). Retrieved. Check date values in: `|accessdate= (help)`, 2009.
28. Eric, K. G., Simons, A., & Elias, K. A. The determination of some design parameters for palm nut crackers. *European Journal of Scientific Research*, 2009; 38(2): 315-327.

29. Ertas, A.; Jones, J. The Engineering Design Process (2nd ed.), 1996.
30. New York, N.Y. John Wiley & Sons, Inc. ISBN 978-0471136996.
31. Fundli, I. S., & Drevland, F. *Collaborative Design Management – A Case Study Paper* presented at the IGLC-22Oslo, Norway, 2014; 25-27.
32. HCL Technologies Limited | www.hcltech.comHertley, C. W. S. The Oil Palm *Elaeisguineensis* Jacq. Longman Scientific and Technical, New York, 3rdEdu. 761 Ndukwu, M.C. and Asoegwu S.N. 2000. Functional Performance of a vertical, 1988.
33. Hubka,V.; Eder, WE.(1996). Design Science (<https://archive.org/details/designscienceint00dipl>). London, UK.: Springer. 126 (<https://archive.org/details/designscienceint00dipl/page/n136>). ISBN 978-3540199977.
34. Holm, Ivar Ideas and Beliefs in Architecture and Industrial design: How attitudes, orientations and underlying assumptions shape the built environment. Oslo School of Architecture and Design. ISBN 82-547, 2006.
35. Gaetan Rwaburindi, 2Saurabh Singh 3Bhargabnanda Dass, Saidu Ibrahim Applying Microsoft Project Profesional Software In Optimizing Safety& Risk Management Systems In Construction By International Journal Of Engineering Sciences & Research Technology, <http://www.ijesrt.com>, 2018.
36. Ismail, S. O., etal Design and development of an improved palm kernel shelling and sorting machine by European International Journal of Science and Technology www.eijst.org.uk, 2015.
37. Jones, Andrew. The Innovation Acid Test. Axminster: Triarchy Press, 2008; 20.
38. Jackson, Andrew (September). From Solving Problems to Selling Product; The Changing Role of Designers in Post war Britain (<http://vads.ac.uk/learning/designingbritain/html/crd.html>). Brighton: University of Brighton, Design History Research Centre, 2002.
39. Joshua Olanrewaju Olaoye1, Timothy Adesoye Adekanye influencing cracking and separation of palm nuts in a mechanical cracker cum separator BY Croatian Journal of Food Science and Technology, 2018.
40. Koya O.A and Faborode M.O Mathematical modeling of palm fruit cracking based on Hertz Theory~ Bio systems Engineering, 2005; 91(4); 471- 7 8.
41. Kathryn Best Design Management In Practice By ‘The Working Principles Of Design ThinkingEngineering Designer Magazine .Kathryn.Best@Btopenworld.Co, 2010.
42. Kaynak, H. "The relationship between total quality management practices and their effects on firm performance". Journal of Operations Management, 2003; 21(4): 405–435. doi:10.1016/s0272-6963(03)00004-4 (<https://doi.org/10.1016%2Fs0272-6963%2803%2900004-4>).

43. Koppelman, Udo *Produktmarketing: Entscheidungsgrundlage Für Produktmanager*. Berlin: Springer-Verlag, 1993; 65. ISBN 978-0-387-55986-5.
44. Knotten, V., Svalestuen, F., Hansen, G. K., & Lædre, O. *Design Management in the Building Process - A Review of Current Literature*. *8th Nordic Conference on Construction Economics and Organization*, 2000; 21(0): 120-127. Lantelme, E., & Formoso, C. T.
45. Krishnan, R.; Kumar, K., "Capturing Value in Global Markets: The Case of Samsung Electronics", *SCMS Journal of Indian Management – Indian Institute of Management Bangalore*, October - December 2005.
46. Koya, O. A., & Fa borode, M. O. *Mathematical modeling of palm nut cracking based on Hertz theory*. *Biosystems Engineering*, 2005; 91(4): 471-478.
47. Kootstra, Geert L.; Jos van der Zwaal *Design management: Design effectief benutten om ondernemingssucces te creëren*. Amsterdam: Pearson Education Benelux, 2006; 451. ISBN 978-90-4301172-3.
48. Khurmi, R. S., & Gupta, J. K. *A Textbook of machine design*. (14th ed.). New Delhi: S.Chand, (Chapter 9), 2006.
49. Lee Bibby *Improving Design Management Techniques In Construction* By Loughborough University, Loughborough Leicestershire LE11 3TU, 2003.
50. Li, B., Habbal, F. and Ortiz, M., "Optimal transportation meshfree approximation schemes for fluid and plastic flows," *International journal for numerical methods in engineering*, 2010; 83(12): 1541-1579.
51. Lovelock, Christopher H. (January 12). "Services Marketing". Prentice Hall College Div. 3 edition. ISBN 978-0134558417, 1996.
52. Mozota, Borja de (March 16–19). "A theoretical model for Design in Management science according to the paradigm shift of the Design profession: from management as a constraint to management science as an opportunity". 1st International Design Management Symposium D2B. Shanghai Jiao Tong University, 2006.
53. Morelli, N.; Sangiorgi, D. "Managing globalization and local issues in service design: on the convergence between opposing demands of industrialisation and personalisation of service performance". In O'Brien, M.A.; Hands, D.; Williams, A.J. (eds.). *Proceedings: D2B – The first international design management symposium*. Adelphi Research Institute for Creative Arts and Sciences. Shanghai: Salford UK., 2006.
54. National Agency for Enterprise and Housing. "The economic effect of design" (https://web.archive.org/web/20110719122542/http://www.ebst.dk/file/1924/the_economic_effects_of_designn.pdf) (PDF). National Agency for Enterprise and Housing. p. 35. Archived

- from the original (http://www.ebst.dk/file/1924_the_economic_effects_of_designn.pdf) (PDF) on 2011-07-19. Retrieved 2011-01-12.
55. Ogburubi, I. U., Ezem, R. E., Eluu, S., Oduma, S., Anosike, P. O., Asogu, G. O. and Okafor, M. C. Practical Manual in General Laboratory Technology, 2009; 40.
 56. OMC (June). Final report - Expert Working Group on maximizing the potential of Cultural and Creative Industries, in particular that of SMEs. OM, 2010.
 57. Okoroigwe, E. C., Ofomata, A. C., Oparaku, N. F. and Unachukwu, G. O. Production and evaluation of activated carbon from palm kernel shells (PKS) for economic and environmental sustainability, *International Journal of Physical Science*, 2013; 8(19): 1036-1038
 58. O.A and Faborode M.O Mathematical modeling of palm fruit cracking based on Hertz's shape 10 design question that can make or break a new consumer product, 2005.
 59. Oriaku E. C., Agulanna, C. N., Edeh J. C., Nwannewuihe H.U, Determination Of Optimal Angle Of Projection And Separation Of Palm Nut Shell And Kernel Using A Designed Cracker/Separator Machine, *International Journal of Scientific & Technology Research*, 2013; 2(10).
 60. Ohimain, E.I., Izah, S.C., Obieze, F.A.U. *Material-mass balance of smallholder oil palm processing in the Niger Delta, Nigeria. Advance J. Food Sci. Technol*, 2013; 5(3): 289-294
 61. Poku, K. *Small-Scale Palm Oil Processing in Africa, (FAO Agricultural Services Bulletin. 148). Rome Italy, 2002; 3-30.*
 62. Rezaee, M., Basri, M., Rahman, R. N. Z. R. A., Salleh, A. B., Chaibakhsh, N. and Karjiban R. A. Formulation development and optimization of palm kernel oil esters-based nanoemulsions containing sodium diclofenac, *Int J Nanomedicine*, 2014; 9: 539–543.
 63. Ralph, P., and Wand, Y. A Proposal for a Formal Definition of the Design concept. In, Lyytinen, K., Loucopoulos, P., Mylopoulos, J., and Robinson, W., (eds.), *Design Requirements Engineering: A Ten-Year Perspective:Springer-Verlag*, 2009; 103-136.
 64. Ralph, P.; Wand, Y. A proposal for a formal definition of the design concept IN: In Lyytinen, K., Loucopoulos, P., Mylopoulos, J., and Robinson, W., editors, *Design Requirements Workshop (LNBIP 14)*, 2009.
 65. Regan, W.J. "The Service Revolution". *Journal of Marketing*, 1963; 27(47): 57–62. doi:10.1177/002224296302700312 (<https://doi.org/10.1177%2F002224296302700312>).
 66. Simeone, Luca (2 September). Interplay between user-centered design and design management in creating an interactive platform to support low carbon economy (<http://www.dmi.org/?page=admc2014>) (pdf). DMI conference. London, 2014; 669–689. Retrieved 20 January 2015 S.L., Ahire; Dreyfus, P. (2000). "The impact of design

- management and process management on quality: an empirical examination". Journal of:10.1016/S0272-6963(00)00029-2 ([https://doi.org/10.1016%2FS02726963 %2800% 290 0029-2](https://doi.org/10.1016%2FS02726963%2000029-2))
67. Tang, T. S., & Teoh, P. K. Palm kernel oil extraction. The Malaysian experience. Journal of the American Oil Chemists' Society, 1985; 62(2): 254-258 Springer-Verlag. pp. 103–136. Operations Management. Elsevier Science B.V., 18(5): 549–575.
68. Thompson A. The World Bank's Palm Oil Mistake, The New York Times, 2010.
69. Then it, Hugo (October). "Design as a tool for innovation" (https://web.archive.org/web/20110202063406/http://grips.proinnoeurope.eu/knowledge_base/view/549). Global Review of Innovation Intelligence and Policy Studies. Brussels: PRO INNO Europe. Archived from the original (http://grips.proinnoeurope.eu/knowledge_base/view/549/) on 2011-02-02. Retrieved 2011-01-30, 2008.
70. Udo, S.B.1 Development of palm kernel nut cracking machine for rural *use by Agric Eng Int: CIGR Journal Open access at <http://www.cigrjournal.org>*, 2015.
71. www.simul8.com / www.imaginetthatinc.com / www.cise.ufl.edu /www.bing.com/search?q=improving+business+processes&FORM=R5FD4.
72. University of Art and Design Helsinki. "125 years history of TAIK" (<http://www.uiah.fi/opintoasiat/history2/125years.htm>). University of Art and Design Helsinki. Retrieved April 24, 2010.
73. Theory bio system engineering, 91(4): 471-78.
74. Walsh, Vivien; Robin Roy; Magaret Bruce "Competitive by design". Journal of Marketing Management, 1988; 4(2): 201–216. doi:10.1080/0267257X.1988.9964069 (<https://doi.org/10.1080%2F0267257X.1988.9964069>).

ID	Task Mode	Task Name	Duration	Start	Finish	Predecessors	Jan 20, '19							Jan 27, '19						
							F	S	S	M	T	W	T	F	S	S	M	T	W	T
1		Fabrication of palm Fruit Bunch Stripper	1 day?	Thu 2/28/19	Thu 2/28/19															
2		Market Analysis	20 days	Fri 1/25/19	Thu 2/21/19															
3		Product Design	25 days	Fri 2/22/19	Thu 3/28/19	2														
4		Product Design Selection	20 days	Thu 3/28/19	Wed 4/24/19															
5		Detailed Market Plan	22 days	Wed 4/24/19	Thu 5/23/19															
6		Manufacturing Proc	27 days	Thu 5/23/19	Fri 6/28/19															
7		Detailed product Design	27 days	Fri 6/28/19	Mon 8/5/19															
8		Testing the Prototype	27 days	Mon 8/5/19	Tue 9/10/19															
9		Finalized Product Design	27 days	Tue 9/10/19	Wed 10/16/19															
10		Ordering of Machine Component	45 days?	Tue 9/10/19	Mon 11/11/19															
11		Ordering of Equipment	40 days	Mon 11/11/19	Fri 1/3/20															
12		Assembling of the components	27 days	Fri 1/3/20	Mon 2/10/20															
13		Installation of the Machine	30 days	Mon 2/10/20	Fri 3/20/20															
14		Test running of the equipment	21 days	Fri 3/20/20	Fri 4/17/20															
15		celebrate	9 days	Fri 4/17/20	Wed 4/29/20															

Project: Project1
Date: Sun 1/20/19

Task		Inactive Summary		External Tasks	
Split		Manual Task		External Milestone	
Milestone		Duration-only		Deadline	
Summary		Manual Summary Rollup		Progress	
Project Summary		Manual Summary		Manual Progress	
Inactive Task		Start-only			
Inactive Milestone		Finish-only			