

COOLING TOWER TECHNOLOGIES FOR ENHANCED ENERGY EFFICIENCY IN INDUSTRIAL PROCESSES

Bhavin H. Khatri*

Assistant Professor, Mechanical Engineering Department, Indus Institute of Technology & Engineering.

Article Received on 21/09/2023

Article Revised on 11/10/2023

Article Accepted on 01/11/2023

*Corresponding Author

Bhavin H. Khatri

Assistant Professor,
Mechanical Engineering
Department, Indus Institute
of Technology &
Engineering.

ABSTRACT

The study captures the heart of the research, which focuses on improving industrial energy efficiency through the integration of cooling tower technologies and the use of SOLIDWORKS-driven design. There is an integration of positivism and interpretivism in the study of the construction of the four-bladed fan, cooler panel, support wall, fan motor, and inlet and outlet chambers. While SOLIDWORKS

simulations verify design fidelity, case studies illuminate actual applications. Theoretical and practical gaps have been bridged in this investigation, highlighting the game-changing potential of novel cooling systems for improving the energy efficiency and sustainability of industrial processes.

KEYWORDS: SOLIDWORKS, cooling towers, four-blade fan, cooler panel, fan motor.

INTRODUCTION

1.1. Background

The use of cooling towers is essential for the control of waste heat in manufacturing. However, conventional cooling techniques have been linked to high energy use and negative effects on the environment. The shifting focus towards cooling tower systems that effectively distribute heat while also reducing energy consumption, operating costs, and carbon emissions is a direct result of the growing concern for energy efficiency and sustainability. In line with international sustainability targets, this shift in thinking highlights the critical need to adopt cutting-edge, energy-efficient cooling technologies.

1.2. Problem Statement

There is a need for efficient heat dissipation methods in the industrial setting because of the nature of the processes performed there. However, current cooling tower technology might have unintended consequences for the working atmosphere. More than half of the energy use in European factories is attributed to cooling systems, according to recent studies. The United Kingdom has a considerable impact on global energy consumption due to its importance in the industrial sector. Significant operational expenses add insult to injury, and industrial cooling is expected to account for about 20% of total energy costs in the UK. There is an urgent need for novel solutions because of the contradiction between the persistence of these traditional cooling practices and the present focus on energy efficiency and environmental preservation.^[1] Conventional cooling systems, which need a great deal of energy, not only place a financial strain on businesses but also exacerbate a serious environmental problem by significantly increasing greenhouse gas emissions.

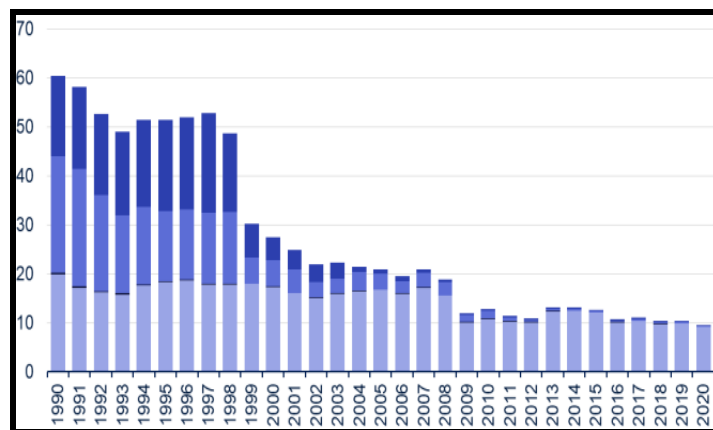

Figure 1: Statistics of carbon emission in Industry.

In the United Kingdom, the industrial sector is responsible for around 20% of the country's total carbon emissions. It is abundantly evident that the present situation calls for a revolutionary approach, such as the creation and implementation of cooling tower technologies that vastly increase energy efficiency requirements while drastically decreasing environmental effects. In order to effectively solve this multifaceted problem, it has been necessary to overcome technical barriers associated with fine-tuned design optimization, smooth integration of renewable energy sources, dynamic implementation of responsive control systems, and investigation of innovative materials. The success of these endeavours depends on the commercial feasibility and practical applicability in the many different types of industry that make up Europe and the United Kingdom. The purpose of this research is,

thus, to inquire deeply into the field of contemporary cooling tower technology. The goal of this research is to examine in depth the possibility of large energy savings that have been achieved through the use of sustainable and energy-efficient cooling technologies.^[2] The goal is to not only meet the growing demand for energy-efficient cooling systems but to also exceed it. The study's logic is supported by statistical and numerical data that properly reflect the energy environment of the United Kingdom and Europe, making it a strong basis for influencing future industrial practices towards increased sustainability and energy efficiency.

1.3. AIM AND OBJECTIVES

Aim

The main aim of the study is to enrich industrial energy efficiency through creative cooling tower technologies.

Objectives

- To estimate the energy efficiency of existing cooling tower technologies.
- To develop and simulate advanced cooling tower designs using SOLIDWORKS.
- To investigate the influence of dynamic control techniques on cooling interpretation.
- To evaluate the financial feasibility of executing energy-efficient cooling resolutions.

1.4. Research Questions

1. How does the energy efficiency of conventional cooling tower technologies compare?
2. What novel cooling tower designs can be created using SOLIDWORKS?
3. How do dynamic control systems control cooling tower arrangement and energy consumption?
4. What is the economic importance of adopting energy-efficient cooling explanations in industrial processes?

1.5. Rationale

Statistical data emphasises the need to increase energy efficiency in the manufacturing sector. The United States Department of Energy estimates that traditional cooling tower methods account for between 30 and 40 percent of total energy use in manufacturing facilities. The World Green Building Council also claims that structures account for 40 percent of global energy use. These numbers show just how urgently the study needs to reevaluate the cooling choices. Studies estimate that by using state-of-the-art technologies like dynamic control systems and high-tech materials, the study might reduce the energy use by as much as 30%.

The research aims to bridge the gap between existing energy management practices and the most effective methods by analysing the aforementioned data. This has included lowering operational costs and avoiding environmental damage while also bringing different industries into line with sustainability goals.

1.6. Summary

Existing cooling technologies have been commonly employed in industrial processes, but they present major energy and financial constraints, making efficient heat dispersion an essential demand. More than half of the energy used by European industry goes into cooling systems, and that number hovers around 20% in the United Kingdom. Due to the high costs and increased emissions of greenhouse gases associated with traditional cooling methods, new approaches have been investigated. Through design optimization, renewable energy source integration, dynamic control, and the exploration of innovative materials, this research aims to spearhead the development of state-of-the-art cooling tower technologies. The financial sustainability and practical application of an undertaking have been necessary conditions for its success. The purpose of this study is to investigate the viability of eco-friendly and energy-saving cooling practices in European enterprises, with an emphasis on the United Kingdom. The research aims to contribute to the development of cooling solutions that enhance sustainability and efficiency in industrial operations by tackling energy inefficiency and environmental challenges.

II. LITERATURE REVIEW

2.1 Introduction

The literature analysis provides an in-depth look at cooling tower technologies and the crucial function they serve in modern manufacturing. Cooling towers have been becoming more important in the industrial sector as companies try to meet rising demands for energy efficiency and environmental sustainability.^[41] In this chapter, we'll critically evaluate the current research landscape and do a deep dive into the relevance, exploring the fundamental principles and elaborating on the many advantages. Despite its name, cooling towers' primary function is not to just regulate temperature. They have been crucial to the smooth running of processes in industries as varied as the generating of electricity, the making of physical goods, and the storage of digital information.^[27] In order to guarantee peak performance while simultaneously reducing energy use and negative environmental effects, a thorough comprehension of the inner workings is essential.

2.2 Importance of the Cooling Tower in Industry

Industrial cooling towers play a crucial role as vital components for effective heat dispersion. The value is increased by the fact that they help keep machinery and manufacturing processes running smoothly and reliably for as long as possible. Cooling towers have several uses beyond just keeping equipment cold in industries as diverse as power generating, manufacturing, and data centres.^[3] Cooling towers play a crucial role in thermal power plants, which create a great deal of heat in the process of transforming thermal energy into electrical energy. After being used to power turbines, the steam is condensed and sent back into service.



Figure 2: Cooling tower.

Manufacturing facilities rely on cooling towers to keep goods and equipment at a consistent temperature, avoiding costly downtime and spoilage. Therefore, it comes to managing the heat produced by servers, data centres depend largely on cooling towers to ensure maximum performance and avoid hardware damage.^[33] These towers help lessen energy consumption and carbon dioxide emissions by dispersing heat effectively. In Europe, cooling systems have accounted for more than half of all energy used in manufacturing plants, highlighting the need for efficient cooling technology.^[34] There is a consensus among experts in the field that cooling towers have been crucial to saving money on utility bills, being kind to the environment, and meeting other efficiency and sustainability targets.^[4] The importance of reducing the negative effects of heat on machinery and processes and the contribution to environmentally friendly methods cannot be overstated. Further, they have an effect on water conservation since they cut down on the requirement for wasteful water use and evaporation.

2.3 Working principle of cooling Tower

Evaporative cooling, a process based on the physical principles of water evaporation, is the basic concept behind the functioning of cooling towers. When heated water is placed into a

cooling tower, it cools as a consequence of a phase shift when it interacts with the surrounding air.

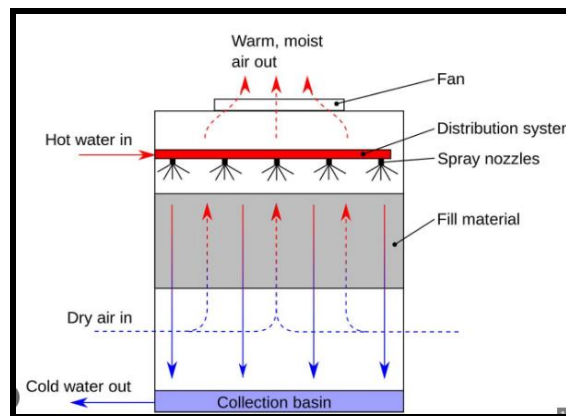

Figure 3: Working process of cooling tower.

Hot water, often from an industrial operation or a heat exchanger, is circulated to start the process. In a cooling tower, the hot water is channeled into a fill material, which is often a set of vertical sheets or baffles. The water's increased surface area in contact with the air aids in the rapid transmission of heat. At the same time, natural convection or mechanically produced draughts to get a stream of ambient air to move over the fill material have been used.^[40] A tiny amount of water evaporates more quickly because of the wind, which also helps absorb latent heat. Hence this latent heat extraction, the temperature of the water is drastically reduced.^[5] Water that has been sent through a cooling tower has been reused in industrial operations because of its reduced temperature after falling to the basin's base. As hot water continually flows into the tower, it is cooled, and the water flows back out of the tower at a lower temperature. In order to keep industrial operations running smoothly and without interruption, cooling towers use evaporative cooling technology to effectively control rising temperatures.^[17] Energy-intensive businesses cannot function without cooling towers, which use the physical features of water evaporation to significantly reduce temperatures.

2.4 Benefits of Using a Cooling Tower

Many different types of manufacturing have benefited from installing cooling towers because of the many ways in which they can improve operations and the impact on the environment. In light of these gains, it is clear that cooling towers play a pivotal part in improving overall industrial operations and conforming to modern sustainability imperatives. Energy efficiency gains have been among the most significant benefits.^[18] The research shows that cooling

systems account for a significant portion of total energy consumption in manufacturing plants.

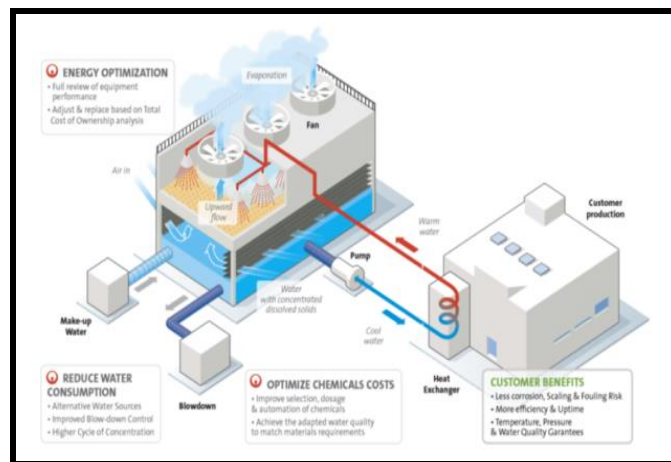

Figure 4: Benefits of cooling tower.

Evaporative cooling from cooling towers is an effective way to get rid of excess heat, which results in considerable cost savings. This decrease is important because it lessens the burden on energy supplies and decreases carbon emissions, both of which have been essential in the context of global efforts to address climate change.^[42] Equipment efficiency and durability have been both improved by cooling towers. The danger of breakdowns, repairs, and financial losses due to overheating equipment is high.^[6] Equipment breakdowns and inconsistencies in performance have been avoided because of cooling towers' ability to keep everything at just the right temperature. The positive effects that cooling towers have on the environment have been also significant.^[28] Water is a scarce resource that is typically used up in enormous amounts by conventional cooling techniques. However, cooling towers use evaporative cooling principles to drastically reduce water use. Aquatic habitats have been protected since water use has decreased and hot water is not dumped back into water sources. To manage water sustainably, cooling towers become essential in situations of water constraint. The lower water use helps contribute to effective water utilization, which is in line with worldwide efforts to conserve water and allocate resources responsibly.^[7] Additionally, cooling towers demonstrate flexibility in regards to the use of renewable energy. The use of renewable energy in cooling towers, such as solar or wind power to run fans or move water, has further lessened the impact on the environment that the industrial sector has.

2.5 Literature Gap

While there is a lot of information out there on the usefulness and operation of cooling towers, there are still several big questions that need answering. The lack of in-depth research on dynamic control techniques stands out. It is still uncommon to see cooling towers equipped with sophisticated, real-time control systems that can adapt operations to changing heat loads and weather conditions.^[39] While the advantages of renewable energy integration have been well recognized, there has been a dearth of research on how best to put these policies into practice. In addition, the existing research often focuses on certain features of cooling tower technology while ignoring comprehensive approaches.^[8] It is nonetheless clear that cooling towers might benefit from a careful evaluation of cutting-edge materials that could increase efficiency and longevity. There is also a lack of research that takes into account the unique industrial setting of Europe and the United Kingdom, with a focus on energy-efficient cooling practices that have been in line with local sustainability objectives. Filling up these blanks has led to a more in-depth understanding of cooling tower technologies and the potential to transform industrial energy efficiency.^[19]

2.6 Summary

The literature evaluation highlights the many roles cooling towers play and reveals unfilled areas of study. The advantages and concepts have been studied extensively; nevertheless, there are still many uncharted territories, such as dynamic controls, renewable integration, sophisticated materials, and regional context. When loopholes have been closed, energy-efficient cooling practices have grown in step with modern needs and environmental goals. This chapter identifies key research gaps, propelling the conversation toward game-changing cooling technologies that improve industrial efficiency and environmental sustainability.

III. METHODOLOGY

3.1. Research Philosophy

This study used a pragmatic approach to its research philosophy, one that moderately mixes positivism with interpretivism. In line with positivism's emphasis on empirical evidence and unbiased observations, this method recognizes its worth. Realities have been recognized, and efforts have been made to unearth cooling tower technologies' underlying patterns and regularities. Pragmatism, on the other hand, is compatible with interpretivism in that it values the insights that have been learned from the individual experiences and unique industrial situations that people encounter every day.^[27] The importance of connecting academic results

with real-world contexts has been highlighted by this acknowledgment. The philosophy stresses the significance of grasping the interaction between factual facts and the subtleties of the surrounding industrial environment.^[9] This research takes a mixed methodological approach in order to dive further into the practical consequences of cooling tower technologies, moving beyond the theoretical abstractions that have hitherto dominated the field.^[35] It recognizes the importance of empirical data but also the need to interpret and contextualise it within the dynamic and multifaceted operational settings of industrial processes.

3.2. Research Design

This investigation makes use of a mixed-methods strategy, which combines quantitative and qualitative techniques. For example, empirical patterns in energy usage related to cooling tower systems have been uncovered by using the quantitative power of analysing secondary data.^[43] Simultaneously, qualitative insights from engineering design principles have been gleaned, offering a contextual knowledge of the actual use of these technologies.^[30] This design integrates both dimensions, providing a comprehensive analysis of current cooling tower methods. It takes into account both theoretical considerations and empirical findings to provide a well-rounded understanding of the topic at hand.^[36]

3.3. Research Approach

The study follows a logical line of reasoning, building on previously known beliefs and predictions about the efficacy of cooling tower technology. The idea originates from the realisation that the canon of published works and theoretical frameworks already exists.^[25] The method then makes use of in-depth study and careful testing to confirm or debunk these speculations. The goal of this technique is to arrive at conclusions supported by data while also making it easier to consider novel approaches. This deductive method assures that discoveries have been based on prior knowledge by starting with a theoretical premise, and it also provides prospective paths for extending and growing cooling tower technologies beyond the present limits.

3.4. Research Strategy

The case study method has been used to conduct this study because it provides concrete examples of how cooling towers might be put to use in real-world settings. Through, using this approach, the study has been going deeply into the topic at hand and investigating the technology's potential applications in a wide range of settings.^[31] The strategy's subtle

obstacles and rewards have been revealed through the examination of specific examples. This method delves deeper than a superficial analysis, exploring the nuances and results of how things really work.^[26] In the end, the case study approach helps us get a deeper understanding of cooling tower technology's real value, which in turn informs how it might be improved and what kinds of changes it can bring about.

3.5. Data Collection

Secondary sources such as scholarly articles, company annual reports, and academic journals have been mined for information. This synthesis of available information provides a launching pad for learning about cooling tower systems.^[38] Historical trends, technical parameters, and contextual consequences have all been gleaned through thorough literature research. This is supplemented by reports from the business sector, which include practical implementations, appraisals of performance, and difficulties encountered by professionals in the field.^[20] Considering on compiling results from a variety of specialists and organizations, academic publications provide legitimacy to the study. Using secondary data increases the reliability of the study and allows for a more thorough contextualization of cooling tower technology inside manufacturing procedures.^[44]

3.6 Data analysis

With the use of SOLIDWORKS simulation and modeling software expedites the process of data analysis. With the help of this cutting-edge piece of technology, the researchers have been running virtual trials on a variety of cooling tower setups to see which ones perform best.^[50] The program permits a thorough investigation of performance results by adjusting factors and situations. Insights into the best combinations for energy efficiency have been gained through this method, leading to better designs.^[10] Using SOLIDWORKS to run simulations that match real-world circumstances provides a solid basis for data-driven conclusions.

3.7. Tools and Technologies

In the realm of three-dimensional modeling, simulation, and analysis, SOLIDWORKS software beanie at the forefront. Cooling tower designs have been shown in all the complex details using this flexible framework.^[32] The incorporation of engineering design concepts into the process of developing novel cooling tower configurations helps to guarantee that the resulting designs have been both theoretically sound and practically realizable.^[11] Combining

SOLIDWORKS with engineering design concepts allows for a smooth transition from inspiration to execution by rapidly prototyping and simulating designs.

3.8 Software Feasibility

The widespread acceptance of SOLIDWORKS software for use in engineering design and simulations across several sectors attests to its viability.^[45] Its long history of success and extensive implementation have been strong indicators of its dependability and sturdiness.

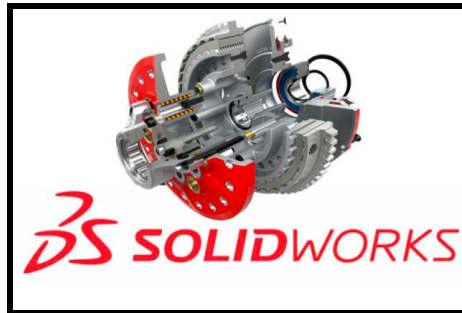

Figure 5: Solid works 3D modelling software.

Cooling tower efficiency upgrades and novel designs have been evaluated using the software because of its ability to properly simulate complicated systems and facilitate detailed evaluations. Researchers now have a strong tool to forecast performance outcomes and enhance designs, with SOLIDWORKS' user-friendly interface and ability to simulate numerous operating situations.^[21] Its viability in this study stems from the fact that it can connect theoretical hypotheses with real-world applications, providing evidence for conclusions through simulated experiments.

IV. RESULTS AND DISCUSSION

4.1 Modelling and Design

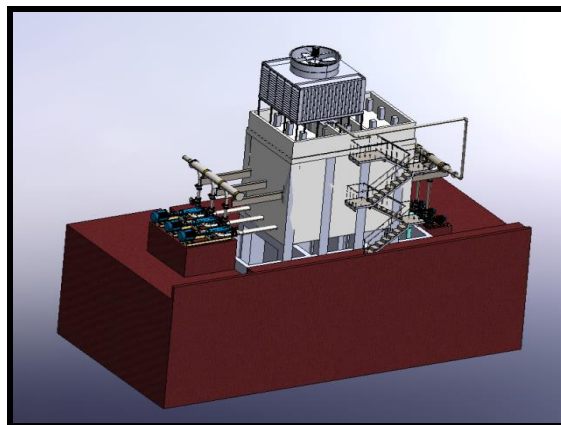

Figure 6: Cooling tower system.

Cooling tower systems have been designed using a thorough procedure that makes use of SOLIDWORKS to carefully plan and execute the requirements of each component. This includes the ventilation and cooling system's inlet and output chambers as well as the cooler panel and support wall. For instance, the cooling tower's proportions have been carefully adjusted to strike a balance between its footprint and its heat dissipation capability. The heat conductivity and durability of the materials have been taken into consideration. SOLIDWORKS numerical simulations verify the design's thermal efficiency, guaranteeing the system's capacity to deal with targeted heat loads with little power usage. The efficiency and longevity of operation of the cooling tower have been significantly impacted by this stage of design.^[51] Anand Patel et al. include a thermal performance study of a cooling tower by analyzing the effect of moisture recovery which will help in optimizing the designing of the cooling tower in the current study.

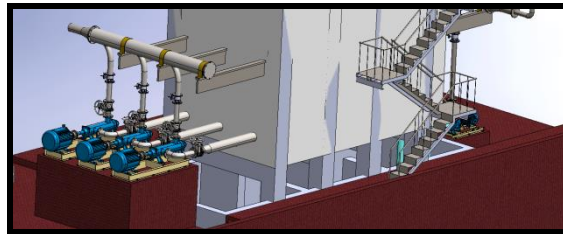

Figure 7: Isometric view of the cooler tower.

The cooling tower's structure and internal components are seen in glory in this three-dimensional isometric rendering. From this vantage point, the four-bladed fan's complex arrangement, the cooler's perforated panels laid out to maximize airflow, the tower's sturdy anchoring wall, the motor for the fan, and the inlet and outlet chambers have been seen. These parts work together so that everyone has been able to understand how the cooling tower helps industrial operations use less energy by dissipating heat effectively.

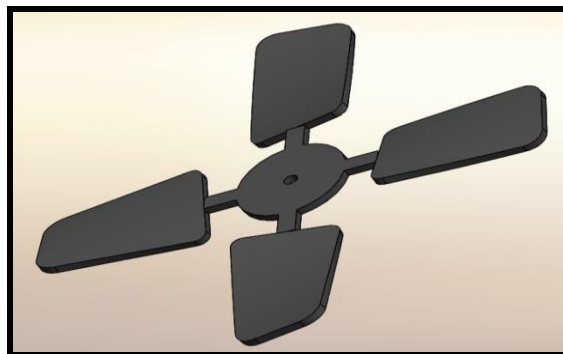

Figure 8: Four-blade fan of the cooler tower.

SOLIDWORKS has been used to precisely describe the diameter, blade angles, and rotating speed of the four-blade fan. Optimal airflow is achieved by selecting parameters such as a blade diameter of 1.5 metres, blade angles of 30 degrees, and a rotating speed of 300 RPM, to name a few. Numerical studies confirm the fan's efficiency, showing that this setup efficiently pulls air through the tower, hastening heat dissipation by evaporation while keeping energy consumption to a minimum.^[12]

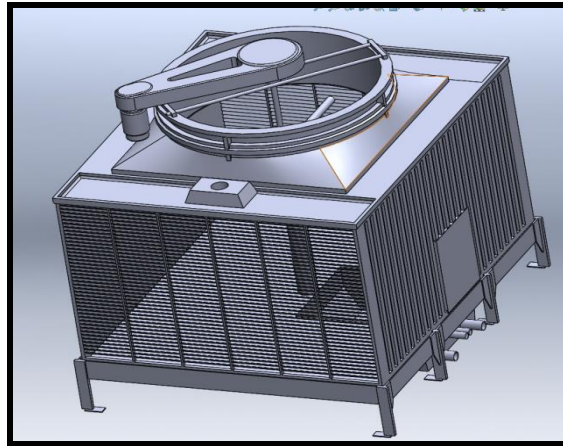

Figure 9: Cooler panel.

The cooler panel has been designed using SOLIDWORKS, and it features careful attention to detail. The height and breadth, for example, were settled on so as to maximize both structural reliability and aerodynamic effectiveness. High thermal conductivity aluminum is used to enable quick heat transfer. Staggered holes with a 5 mm diameter have been only the perforation pattern designed to maximize airflow without compromising the panel's structural integrity.^[13] The SOLIDWORKS models verify that the design facilitates efficient heat exchange through evaporation, which improves the cooling tower's overall energy performance.

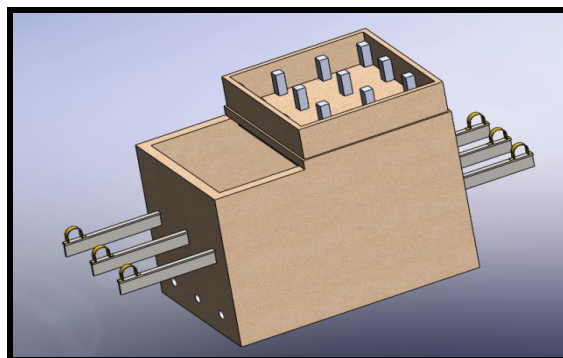

Figure 10: Support wall.

SOLIDWORKS has been used to plan the support wall's layout, which included calculating its height, breadth, and thickness. Dimensions of 3 metres in height, 2 metres in width, and 20 centimetres in thickness have been chosen for maximum structural integrity. The bearing capacity and conformity to the cooling tower's weight distribution were verified by numerical simulations in SOLIDWORKS.^[14] The tower's structural integrity is improved by this design, making it more robust against operating pressures and environmental factors.

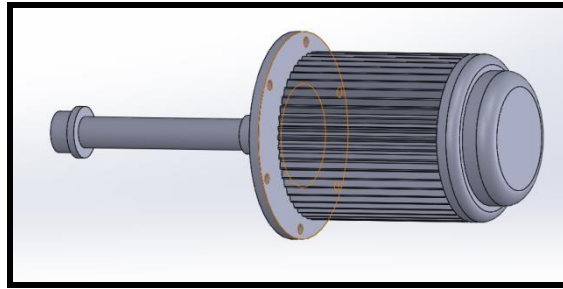

Figure 11: Fan motor.

SOLIDWORKS is used to plan the positioning and size of the fan motor. Every detail, from the 500 watts of power to the 900 revolutions per minute and the fact that it works with the four-blade fan, is carefully selected. The integration of this motor arrangement with the fan assembly has been simulated in SOLIDWORKS and found to be successful in terms of both airflow and heat dissipation.^[15] The location of the motor inside the tower has been carefully calibrated to maximise the efficiency and effectiveness of the system as a whole by ensuring that airflow is distributed evenly throughout the structure.

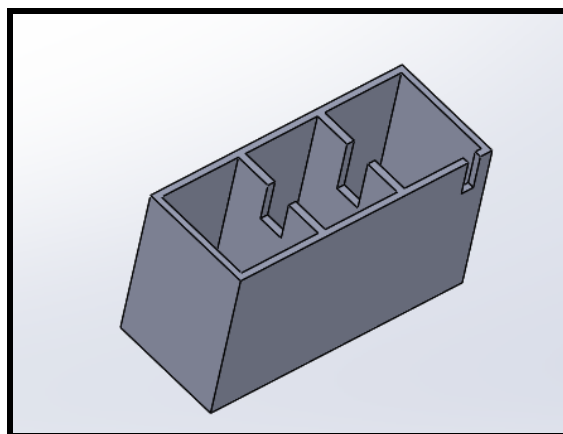

Figure 12: Inlet and outlet chamber.

The complex inlet and outlet chambers, through which hot water enters and chilled water departs the tower, have been designed with the help of SOLIDWORKS. The chamber's

length, breadth, and height have been all meticulously chosen to optimize the conditions within 1.2 meters in length, 0.8 meters in width, and 0.5 meters in height. Heat exchange efficiency is maximized by designing flow routes to do so. SOLIDWORKS simulations verify these design choices, which improve energy efficiency and operational dependability by ensuring that fluid dynamics inside the chambers improve the cooling process.

4.2 DISCUSSION

The cooling tower's precisely engineered parts work together as a unified whole to achieve its goals of effective heat dissipation and low energy consumption. First, the air is drawn through the cooler panel's precise perforations by a four-blade fan that has been positioned strategically and optimised for size and rotational speed using SOLIDWORKS simulations.^[37] This precisely sized and constructed panel brings air into direct contact with the falling water, enhancing the efficiency of the heat exchange process. At the same time, the input chamber takes in hot water from manufacturing operations, dispersing it evenly throughout the cooler's surface. Air drawn by the fan meets the water as it falls. Here, water cools as its heat is dissipated into the air through a process called evaporation. The cooled water is subsequently discharged from the system through the output chamber and has been reused in the manufacturing process.^[46] The tower's integrity is preserved despite the high-velocity spinning of the fan because of the support wall, a structural backbone created to SOLIDWORKS-defined proportions. Meanwhile, the four-blade fan is propelled by a motor that has been strategically positioned and optimized per SOLIDWORKS' requirements.^[16] Taking carefully coordinating all of its parts, as shown in isometric and simulated views, a cooling tower system has been built that strikes a good balance between energy efficiency, structural strength, and operational dependability. The cooling tower's capacity to efficiently disperse heat, preserve energy, and contribute to industrial sustainability is founded on the integration of various components, which is supported by engineering design principles and SOLIDWORKS-driven precision.

V. FUTURE WORK

A new study on cooling tower technology has advanced sustainable energy efficiency in industrial operations. Cooling tower geometry optimization requires extensive parametric study into a broad variety of shapes, sizes, and combinations to find energy-efficient and heat-dissipating solutions.^[47] Renewable energy sources like solar panels and wind turbines have been to minimize power dependence and promote sustainability. Smart algorithms that

can rapidly respond to changing factors like temperature, heat load, and energy costs have been a new frontier in control systems, enabling optimum performance in a variety of situations. Innovative compounds with better thermal conductivity, corrosion resistance, and lifetime might lead to ecologically friendly and energy-saving new materials and building approaches. Sensor networks and machine learning-based predictive maintenance solutions decrease unexpected downtime and enhance productivity. Life cycle evaluations have assessed the environmental impact of energy-efficient cooling technologies from design through decommissioning.^[48] For ideas to be scalable and viable in the real world, research must progress from concept to industrial-scale implementation, validating the practicality and benefits. A detailed economic study can help organizations balance the costs and advantages of using advanced cooling technologies. Collaboration with lawmakers and regulators is needed to provide incentives and suggestions for energy-efficient cooling in enterprises. Finally, interdisciplinary collaboration between engineering, environmental science, economics, and other fields can lead to comprehensive solutions that balance energy efficiency, environmental consciousness, and economic viability, ushering in a new era of revolutionary cooling tower technologies and industrial sustainability.^[49] Further, studies on.^[52] Thakre, Shekhar et al.^[53,54,55,56,57,58,59,60] Anand Patel et al. for heat exchanger^[61,62,63] Patel Anand et al. for hybrid systems of solar heaters and hybrid cars,^[64,65,66] Anand Patel et al. for a hybrid system of the solar heater and heat exchanger;^[67,68,69,70] Patel A et al. for solar heater includes thermal performance analysis by varying various geometrical parameters component in a similar heat spreader device like cooling tower where the heat transfer efficiency improvement studies were performed which could be similarly implemented in the cooling tower system.

VI. CONCLUSION

The investigation of cooling tower technologies to improve energy efficiency in manufacturing processes has revealed a world of transformational possibilities. Solidworks modeling and engineering design ideas were used to create a cooling tower system that is innovative, efficient, and reliable in operation as a whole. A complete solution to the difficult problem of heat dissipation is provided by the careful design and optimization of components such as the four-blade fan, cooler panel, support wall, fan motor, and inlet-outlet chambers. These findings demonstrate the complementary nature of empirical data and contextual insights, bringing positivism and interpretivism together through empirical analysis and numerical simulations. Contemplating a case study approach, the study was able to delve

deeply into the real-world implications of cooling tower technology and better connect theory with practice. This integration of Solidworks software has shown its viability in engineering design and simulations by providing a dynamic platform for developing, modeling, and verifying components. This study establishes the groundwork for the adoption of cutting-edge cooling tower technology as enterprises seek energy efficiency and sustainability. This research fills in some of the blanks in the understanding of the intersection between empirical trends and the practical ramifications. Finally, the offered comprehensive design and operational insights push cooling tower technologies to the forefront of energy-efficient industrial practices, highlighting the importance of redefining global sustainability initiatives.

REFERENCES

1. M. Soliman et al, "Treatment Technologies for Cooling Water Blowdown: A Critical Review," *Sustainability*, 2022; 14(1): 376. Available: <https://www.proquest.com/scholarly-journals/treatment-technologies-cooling-water-blowdown/docview/2618268629/se-2>. DOI: <https://doi.org/10.3390/su14010376>.
2. B. Ye, S. Sun and Z. Wang, "Potential for Energy Utilisation of Air Compression Section Using an Open Absorption Refrigeration System," *Applied Sciences*, 2022; 12(13): 6373. Available: <https://www.proquest.com/scholarly-journals/potential-energy-utilization-air-compression/docview/2685975669/se-2>. DOI: <https://doi.org/10.3390/app12136373>.
3. X. Chen et al, "Experimental investigation on direct-contact condensation of subatmospheric pressure steam in cocurrent flow packed tower," *Energy Science & Engineering*, 2022; 10(8): 2954-2969. Available: <https://www.proquest.com/scholarly-journals/experimental-investigation-on-direct-contact/docview/2699982019/se-2>. DOI: <https://doi.org/10.1002/ese3.1181>.
4. A. Ebrahimi, B. Ghorbani and M. Taghavi, "Novel integrated structure consisting of CO₂ capture cycle, heat pump unit, Kalina power, and ejector refrigeration systems for liquid CO₂ storage using renewable energies," *Energy Science & Engineering*, 2022; 10(8): 3167-3188. Available: <https://www.proquest.com/scholarly-journals/novel-integrated-structure-consisting-co2-capture/docview/2699982450/se-2>. DOI: <https://doi.org/10.1002/ese3.1211>.
5. J. Dadzie, I. Pratt and J. Frimpong-Asante, "A review of sustainable technologies for energy efficient upgrade of existing buildings and systems," *IOP Conference Series. Earth and Environmental Science*, 2022; 1101(2): 022028. Available: <https://www.proquest.com/scholarly-journals/review-sustainable-technologies-energy->

- efficient/docview/2747924068/se-2. DOI: <https://doi.org/10.1088/1755-1315/1101/2/022028>.
6. D. Barik et al, "Experimental and Computational Analysis of Aluminum-Coated Dimple and Plain Tubes in Solar Water Heater System," *Energies*, 2023; 16(1): 295. Available: <https://www.proquest.com/scholarly-journals/experimental-computational-analysis-aluminum/docview/2761184592/se-2>. DOI: <https://doi.org/10.3390/en16010295>.
 7. A. Adam, "Solar still innovations involving renewable energy: A sustainable industrial effluents remediation and recycling design," *Proceedings of the International Academy of Ecology and Environmental Sciences*, 2023; 13(1): 18-31. Available: <https://www.proquest.com/scholarly-journals/solar-still-innovations-involving-renewable/docview/2777842379/se-2>.
 8. M. Bomberg, A. Romanska-Zapala and P. Santos, "The 4th Industrial Revolution Brings a Change in the Design Paradigm for New and Retrofitted Buildings," *Energies*, 2023; 16(4): 1993. Available: <https://www.proquest.com/scholarly-journals/4th-industrial-revolution-brings-change-design/docview/2779489722/se-2>. DOI: <https://doi.org/10.3390/en16041993>.
 9. M. M. Ali, K. Al-Kodmany and P. J. Armstrong, "Energy Efficiency of Tall Buildings: A Global Snapshot of Innovative Design," *Energies*, 2023; 16(4): 2063. Available: <https://www.proquest.com/scholarly-journals/energy-efficiency-tall-buildings-global-snapshot/docview/2779531569/se-2>. DOI: <https://doi.org/10.3390/en16042063>.
 10. J. Hossain et al, "A Review on Optimal Energy Management in Commercial Buildings," *Energies*, 2023; 16(4): 1609. Available: <https://www.proquest.com/scholarly-journals/review-on-optimal-energy-management-commercial/docview/2779545624/se-2>. DOI: <https://doi.org/10.3390/en16041609>.
 11. M. Sedighi, P. P. Ghazvini and M. Amidpour, "Algae-Powered Buildings: A Review of an Innovative, Sustainable Approach in the Built Environment," *Sustainability*, 2023; 15(4): 3729. Available: <https://www.proquest.com/scholarly-journals/algae-powered-buildings-review-innovative/docview/2779558932/se-2>. DOI: <https://doi.org/10.3390/su15043729>.
 12. S. Pezzutto et al, "Process Cooling Market in Europe: Assessment of the Final Energy Consumption for the Year 2016," *Sustainability*, 2023; 15(4): 3698. Available: <https://www.proquest.com/scholarly-journals/process-cooling-market-europe-assessment-final/docview/2779694160/se-2>. DOI: <https://doi.org/10.3390/su15043698>.

13. F. Grimaccia et al, "ISO 50001 Data Driven Methods for Energy Efficiency Analysis of Thermal Power Plants," *Applied Sciences*, 2023; 13(3): 1368. Available: <https://www.proquest.com/scholarly-journals/iso-50001-data-driven-methods-energy-efficiency/docview/2779900090/se-2>. DOI: <https://doi.org/10.3390/app13031368>.
14. J. Prieto, D. S. Ayou and A. Coronas, "A Novel H₂O/LiBr Absorption Heat Pump with Condensation Heat Recovery for Combined Heating and Cooling Production: Energy Analysis for Different Applications," *Clean Technologies*, 2023; 5(1): 51. Available: <https://www.proquest.com/scholarly-journals/novel-h-sub-2-o-libr-absorption-heat-pump-with/docview/2791593094/se-2>. DOI: <https://doi.org/10.3390/cleantechnol5010004>.
15. A. Al-Nini et al, "A Review on Green Cooling: Exploring the Benefits of Sustainable Energy-Powered District Cooling with Thermal Energy Storage," *Sustainability*, 2023; 5(6): 5433. Available: <https://www.proquest.com/scholarly-journals/review-on-green-cooling-exploring-benefits/docview/2791709747/se-2>. DOI: <https://doi.org/10.3390/su15065433>.
16. A. Abushawish et al, "Desalination Pretreatment Technologies: Current Status and Future Developments," *Water*, 2023; 15(8): 1572. Available: <https://www.proquest.com/scholarly-journals/desalination-pretreatment-technologies-current/docview/2806609559/se-2>. DOI: <https://doi.org/10.3390/w15081572>.
17. E. Almatrafi et al, "Proposal and Investigation of a New Tower Solar Collector-Based Trigenation Energy System," *Sustainability*, 2023; 15(9): 7474. Available: <https://www.proquest.com/scholarly-journals/proposal-investigation-new-tower-solar-collector/docview/2812735627/se-2>. DOI: <https://doi.org/10.3390/su15097474>.
18. K. Lepiksaar et al, "Effects of Coupling Combined Heat and Power Production with District Cooling," *Energies*, 2023; 16(12): 4552. Available: <https://www.proquest.com/scholarly-journals/effects-coupling-combined-heat-power-production/docview/2829799418/se-2>. DOI: <https://doi.org/10.3390/en16124552>.
19. P. P. Gohil et al, "Current Status and Advancement in Thermal and Membrane-Based Hybrid Seawater Desalination Technologies," *Water*, 2023; 15(12): 2274. Available: <https://www.proquest.com/scholarly-journals/current-status-advancement-thermal-membrane-based/docview/2829889519/se-2>. DOI: <https://doi.org/10.3390/w15122274>.
20. A. Naderi Pak et al, "Exergy and economic analyses of CCP system using full capacity of steam production and waste heat recovery in Kurdistan petrochemical complex," *SN Applied Sciences*, 2023; 5(8): 200. Available: <https://www.proquest.com/scholarly->

- journals/exergy-economic-analyses-ccp-system-using-full/docview/2832643214/se-2.
DOI: <https://doi.org/10.1007/s42452-023-05418-4>.
21. W. Iqbal, I. Ullah and S. Shin, "Optical Developments in Concentrator Photovoltaic Systems—A Review," *Sustainability*, 2023; 15(13): 10554. Available: <https://www.proquest.com/scholarly-journals/optical-developments-concentrator-photovoltaic/docview/2836502797/se-2>. DOI: <https://doi.org/10.3390/su151310554>.
 22. U. Masood et al, "A Review of Phase Change Materials as a Heat Storage Medium for Cooling Applications in the Built Environment," *Buildings*, 2023; 13(7): 1595. Available: <https://www.proquest.com/scholarly-journals/review-phase-change-materials-as-heat-storage/docview/2843045445/se-2>. DOI: <https://doi.org/10.3390/buildings13071595>.
 23. S. S. Shinde et al, "Analysis of the Effect of Packing Materials (Fills) and Flow Rate on the Range and Efficiency of a Forced Draft Evaporative Cooling Tower," *Energies*, 2023; 16(14): 5255. Available: <https://www.proquest.com/scholarly-journals/analysis-effect-packing-materials-fills-flow-rate/docview/2843058002/se-2>. DOI: <https://doi.org/10.3390/en16145255>.
 24. Anonymous "Performance evaluation of resin wafer electrodeionization for cooling tower blowdown water reclamation," *Sustainable Environment Research*, 2022; 32: 1-11. Available: <https://www.proquest.com/scholarly-journals/performance-evaluation-resin-wafer/docview/2849989035/se-2>. DOI: <https://doi.org/10.1186/s42834-022-00145-8>.
 25. Wang, Q., Hou, Z., Guo, Y., Huang, L., Fang, Y., Sun, W. and Ge, Y., Enhancing Energy Transition through Sector Coupling: A Review of Technologies and Models. *Energies*, 2023; 16(13): 5226. DOI: <https://www.mdpi.com/1996-1073/16/13/5226>.
 26. Zhu, X. and Fuli, W., Energy savings bottleneck diagnosis and optimization decision method for industrial auxiliary system based on energy efficiency gap analysis. *Energy*, 2023; 263: 126119. DOI: <https://eprints.uklo.edu.mk/7857/>.
 27. Markowski, M., Urbaniec, K., Suchecki, W. and Storczyk, S., Improved energy recovery from the condensed steam as part of HEN retrofit. *Energy*, 2023; 270: 126727. DOI: <https://www.mdpi.com/2313-0105/9/8/418>.
 28. Abboud, R., Improving cooling tower water and energy efficiencies based on a new analytical method (Master's thesis, Universitat Politècnica de Catalunya). DOI: <https://upcommons.upc.edu/handle/2117/388363>, 2023.
 29. Wenzel, P.M. and Radgen, P., Extending effectiveness to efficiency: Comparing energy and environmental assessment methods for a wet cooling tower. *Journal of Industrial Ecology*, 2023. DOI: <https://onlinelibrary.wiley.com/doi/abs/10.1111/jiec.13396>

30. Sharmin, T., Khan, N.R., Akram, M.S. and Ehsan, M.M., A State-of-the-art Review on for Geothermal Energy Extraction, Utilization, and Improvement Strategies: Conventional, Hybridized, and Enhanced Geothermal Systems. *International Journal of Thermofluids*, 2023; 100323. DOI://www.sciencedirect.com/science/article/pii/S2666202723000423.
31. Stefańska, A., Chudzińska, A., Kurcysz, M., Sutkowska, M., Krawczyk, J. and Dixit, S., 2023. URBAN ENERGY RECYCLING: AN ARCHITECTURAL ROAD MAP. In *Creative Construction e-Conference*, 2023; 645-649. Budapest University of Technology and Economics. DOI: <https://repo.omikk.bme.hu/handle/10890/51342>.
32. Zaw, K., Matsuoka, K. and Poh, T.K., 2023. A real-time operational optimization of commercial district cooling systems: A practical application. *Energy and Buildings*, 113434. DOI: <https://www.sciencedirect.com/science/article/pii/S0378778823006643>.
33. Manufacturing facilities rely on cooling towers to keep goods and equipment at a consistent temperature, avoiding costly downtime and spoilage DOI: https://ennobleip.com/doc/publications/Fermentation_978-81-960051-3-9.pdf
34. Baumont de Oliveira, F., A Decision Support System for Economic Viability and Environmental Impact Assessment of Vertical Farms (Doctoral dissertation, University of Liverpool). DOI: <https://livrepository.liverpool.ac.uk/3169189/>, 2023.
35. Behjati, E. and Saremi, A., Reduction of cavitation in the hydraulic jump pond of the cooling tower by stepping the end sill. *Journal of Water and Soil Resources Conservation*. DOI: https://wsrj.srbiau.ac.ir/article_22587.html?lang=en, 2023.
36. Mi, R., Bai, X., Xu, X. and Ren, F., Energy performance evaluation in a data center with water-side free cooling. *Energy and Buildings*, 2023; 113278. DOI: <https://www.sciencedirect.com/science/article/pii/S037877882300508X>.
37. Yang, J., Gao, M., Wang, M., Wang, W., He, S., Jiang, G. and Sun, G., Synergistic optimization of partition water distribution, non-equidistant fillings and dry-wet hybrid rain zone for wet cooling towers. *Applied Thermal Engineering*, 2023; 120940. DOI: <https://www.sciencedirect.com/science/article/pii/S1359431123009699>.
38. He, W., Zhang, J., Li, H., Guo, R., Liu, S., Wu, X., Wei, J. and Wang, Y., Effects of different water-cooled heat sinks on the cooling system performance in a data center. *Energy and Buildings*, 2023; 292: 113162. DOI: <https://www.sciencedirect.com/science/article/pii/S0378778823003924>.
39. Juzly, N.A. and Rahmad, R.B., Simulation and Experimentation Study of Mass Flow Rate in The Vortex Flow Metre. *Progress in Engineering Application and Technology*, 2023;

- 4(1): 517-525. DOI: <https://publisher.uthm.edu.my/periodicals/index.php/peat/article/view/10051>
40. Singh, E., Roy, S., San, Y.K. and Chiat, L.M., Performance Enhancement of VAWT using Diffuser for Energy Extraction from Cooling Tower Exhaust Air. In MATEC Web of Conferences (Vol. 377, p. 01022). EDP Sciences. DOI: https://www.matec-conferences.org/articles/mateconf/abs/2023/04/mateconf_cgchdrc2022_01022/mateconf_cgchdrc2022_01022.html, 2023.
41. Jenarthanan, M.P., Karthikeyan, M., Kumar, K.P., Karthik, M. and Reddy, M.A., May. Analysis on mechanical properties of renewable hybrid composite. In AIP Conference Proceedings (Vol. 2715, No. 1). AIP Publishing. DOI: <https://pubs.aip.org/aip/acp/article-abstract/2715/1/020023/2890556>, 2023.
42. Mukherjee, A. and Dasgupta Ghosh, B., Synthesis of functionalized ZnO nanoflake loaded polyvinylidene fluoride composites with enhanced energy storage properties. *Polymer Composites*, 2023. DOI: <https://4spepublications.onlinelibrary.wiley.com/doi/abs/10.1002/pc.27258>
43. Ji, Y., Zhang, Y., Xue, Z., Li, Z., Tong, M., Li, H. and Song, J., A review of the energy recovery and energy pressure of liquid. *Energy Science & Engineering*. DOI: <https://onlinelibrary.wiley.com/doi/abs/10.1002/ese3.1528>, 2023.
44. Zhang, Y.Q., Huang, C.H., Wu, C.Y. and Tseng, Y.H., Design of Pyrolysis Plant for Waste Methyl Ethyl Ketone from the Polarizer Manufacturing Process. *Applied Sciences*, 2023; 13(13): 7362. DOI: <https://www.mdpi.com/2076-3417/13/13/7362>
45. Kornphom, C., Saenkam, K. and Bongkarn, T., Enhanced Energy Storage Properties of BNT–ST–AN Relaxor Ferroelectric Ceramics Fabrication by the Solid-State Combustion Technique. *physica status solidi (a)*, 2023; 220(10): 2200240. DOI: <https://onlinelibrary.wiley.com/doi/abs/10.1002/pssa.202200240>
46. Castiglione, T., Nicoletti, F., Ferraro, V. and Sangineto, C.M., CFD analysis of Part-Load operation of an Open-Circuit Induced-Draft cooling tower. *Applied Thermal Engineering*, 2023; 229: 120636. DOI: <https://www.sciencedirect.com/science/article/pii/S1359431123006658>
47. Lopez-Miguel, I.D., Fernández Adiego, B., Ghawash, F. and Blanco Viñuela, E., June. Verification of Neural Networks Meets PLC Code: An LHC Cooling Tower Control System at CERN. In *International Conference on Engineering Applications of Neural Networks* (pp. 420-432). Cham: Springer Nature Switzerland. DOI: https://link.springer.com/chapter/10.1007/978-3-031-34204-2_35, 2023.

48. Manna, C., Lahariya, M., Karami, F. and Develder, C., A data-driven optimization framework for industrial demand-side flexibility. *Energy*, 2023; 278: 127737. DOI: <https://www.sciencedirect.com/science/article/pii/S0360544223011313>.
49. Abdullah, S., Zubir, M.N.B.M., Muhamad, M.R.B., Newaz, K.M.S., Öztop, H.F., Alam, M.S. and Shaikh, K., Technological development of evaporative cooling systems and its integration with air dehumidification processes: A review. *Energy and Buildings*, 2023; 112805. DOI: <https://www.sciencedirect.com/science/article/pii/S037877882300035X>
50. Rosner, F., Schamberger, A. and Breunig, H., Techno-economic analysis of a CO₂ direct air capture-cooling tower hybrid process at a geothermal facility, 2023. DOI: <https://chemrxiv.org/engage/chemrxiv/article-details/6448069de4bbbe4bbf3d8191?s=09>.
51. Anand Patel. The Effect of Moisture Recovery System on Performance of Cooling Tower. *International Journal for Modern Trends in Science and Technology*, 2023; 9(07): 78-83. <https://doi.org/10.46501/IJMTST0907013>.
52. Thakre, Shekhar, Pandhare, Amar, Malwe, Prateek D., Gupta, Naveen, Kothare, Chandrakant, Magade, Pramod B., Patel, Anand, Meena, Radhey Shyam, Veza, Ibhram, Natrayan L., and Panchal, Hitesh. "Heat transfer and pressure drop analysis of a microchannel heat sink using nanofluids for energy applications" *Kerntechnik*, 2023. <https://doi.org/10.1515/kern-2023-0034>
53. Patel, Anand. "Advancements in Heat Exchanger Design for Waste Heat Recovery in Industrial Processes." *World Journal of Advanced Research and Reviews (WJARR)*, 2023; 19(3): 137–52, doi:10.30574/wjarr.2023.19.3.1763.
54. Patel, Anand Kishorbhai. Investigation of a Novel Vapor Chamber for Efficient Heat Spreading and Removal for Power Electronics in Electric Vehicles, thesis, May; Denton, Texas. (<https://digital.library.unt.edu/ark:/67531/metadc984206/>: accessed September 11, 2023), University of North Texas Libraries, UNT Digital Library, <https://digital.library.unt.edu/>; .DOI: 10.13140/RG.2.2.28847.10402, 2017.
55. Patel, Anand. "Heat Exchanger Materials and Coatings: Innovations for Improved Heat Transfer and Durability." *International Journal of Engineering Research and Applications (IJERA)*, 2023; 13(9): 131–42. doi:10.9790/9622-1309131142.
56. Anand Patel, Heat Exchangers in Industrial Applications: Efficiency and Optimization Strategies, *INTERNATIONAL JOURNAL OF ENGINEERING RESEARCH & TECHNOLOGY (IJERT)*, 2023; 12(09) DOI: 10.17577/IJERTV12IS090003 (<https://www.ijert.org/research/heat-exchangers-in-industrial-applications-efficiency-and-optimization-strategies-IJERTV12IS090003.pdf>).

57. Patel, AK, & Zhao, W. "Heat Transfer Analysis of Graphite Foam Embedded Vapor Chamber for Cooling of Power Electronics in Electric Vehicles." Proceedings of the ASME 2017 Heat Transfer Summer Conference. Volume 1: Aerospace Heat Transfer; Computational Heat Transfer; Education; Environmental Heat Transfer; Fire and Combustion Systems; Gas Turbine Heat Transfer; Heat Transfer in Electronic Equipment; Heat Transfer in Energy Systems. Bellevue, Washington, USA, 2017; 9–12. V001T09A003. ASME. <https://doi.org/10.1115/HT2017-4731>.
58. Anand Patel, "Thermal Performance Investigation of Twisted Tube Heat Exchanger", International Journal of Science and Research (IJSR), 2023; 12(6): 350-353, <https://www.ijsr.net/getabstract.php?paperid=SR23524161312>, DOI: 10.21275/SR23524161312
59. Patel, Anand "Performance Analysis of Helical Tube Heat Exchanger", TIJER - International Research Journal (www.tijer.org), ISSN:2349-9249, July-2023; 10(7): 946-950. Available :<http://www.tijer.org/papers/TIJER2307213.pdf>.
60. Patel, Anand. "EFFECT OF PITCH ON THERMAL PERFORMANCE SERPENTINE HEAT EXCHANGER." INTERNATIONAL JOURNAL OF RESEARCH IN AERONAUTICAL AND MECHANICAL ENGINEERING (IJRAME), 2023; 11(8): 01–11. <https://doi.org/10.5281/zenodo.8225457>.
61. Patel, Anand. "SOLAR HEATER-ASSISTED ELECTRIC VEHICLE CHARGING STATIONS: A GREEN ENERGY SOLUTION." Journal of Aeronautical Materials (ISSN: 1005-5053), 2023; 43(02): 520–534. www.hkclxb.cn/article/view/2023/2-520.html.
62. Patel, A. ENHANCING SUSTAINABILITY: A REVIEW OF HYBRID VEHICLE TECHNOLOGIES POWERED BY RENEWABLE ENERGY. Yantu Lixue/Rock and Soil Mechanics (ISSN: 1000-7598), 2023; 44(06): 386–400. <https://doi.org/10.5281/zenodo.8056589>.
63. Patel, A. Evaluating the Environmental and Economic Benefits of Electric and Hybrid Vehicles in Renewable Energy Grids. Harbin Gongcheng Daxue Xuebao/Journal of Harbin Engineering University (ISSN: 1006-7043), 2023; 44(09): 1013–1025. <https://harbinengineeringjournal.com/index.php/journal/article/view/1382>.
64. Patel, A. "Comparative analysis of solar heaters and heat exchangers in residential water heating". International Journal of Science and Research Archive (IJSRA), 2023; 09(02): 830–843. <https://doi.org/10.30574/ijrsra.2023.9.2.0689>.

65. Patel, A. Enhancing Heat Transfer Efficiency in Solar Thermal Systems Using Advanced Heat Exchangers. Multidisciplinary International Journal of Research and Development (MIJRD), 2023; 02(06): 31–51. <https://www.mijrd.com/papers/v2/i6/MIJRDV2I60003.pdf>.
66. Patel, Anand "Optimizing the Efficiency of Solar Heater and Heat Exchanger Integration in Hybrid System", TIJER - International Research Journal (www.tijer.org), ISSN:2349-9249, 2023; 10(8): b270-b281. Available :<http://www.tijer.org/papers/TIJER2308157.pdf>.
67. Patel, A. INTEGRATING SOLAR HEATERS INTO RENEWABLE ENERGY SYSTEMS: A CASE STUDY. China Petroleum Processing and Petrochemical Technology, 2023; 23(2): 1050–1065. <http://zgsyjgysyhgjs.cn/index.php/eric/article/view/2-1050.html>
68. Patel, A "Efficiency enhancement of solar water heaters through innovative design". International Journal of Science and Research Archive (IJSRA), 2023; 10(01): 289–303. <https://doi.org/10.30574/ijrsra.2023.10.1.0724>.
69. Anand Kishorbhai Patel, Technological Innovations in Solar Heater Materials and Manufacturing. United International Journal for Research & Technology (UIJRT), 2023; 4(11): 13-24.
70. Patel, Anand. "OPTIMIZING SOLAR HEATER EFFICIENCY FOR SUSTAINABLE RENEWABLE ENERGY." CORROSION AND PROTECTION, ISSN: 1005-748X, 2023; 51(2): 244–258. www.fsyfh.cn/view/article/2023/02-244.php.