

**AUTOMATIC NOTIFICATION AND EARLY RESCUE DURING  
AUTOMOTIVE ACCIDENTS AND TRAFFIC CONTROL SYSTEM.****Sushma N,\*<sup>1</sup> Rashmi HR,<sup>1</sup> Divya P. Naik,<sup>1</sup> Parameshwar and Ganga B.<sup>2</sup>**<sup>1</sup>BE, Student of M.S.E.C, Bangalore, India.<sup>2</sup>Assistant Professor, Dept. of computer science and Engineering, M.S. Engineering College.  
Bangalore, India.

Article Received on 10/04/2016

Article Revised on 01/05/2016

Article Accepted on 21/05/2016

**\*Corresponding Author****Sushma N.**BE, Student of M.S.E.C,  
Bangalore, India.**ABSTRACT**

New communication technologies integrated into modern vehicles offer an opportunity for better assistance to people injured in traffic accidents. Recent studies show how communication capabilities should be supported by artificial intelligence systems capable of automating many of the decisions to be taken by emergency services, thereby adapting the rescue resources to the severity of the accident and reducing assistance time. To improve the overall rescue process, a fast and accurate estimation of the severity of the accident represent a key point to help emergency services better estimate the required resources. This paper proposes a novel intelligent system which is able to automatically detect road accidents and notify them. Initially GPS continuously takes the input data from the satellite and stores the latitude and longitude values in renesas microcontroller buffer. If we have to track the vehicle, we need send message to GSM device, by which it gets activated .once the GSN gets activated it takes the last received latitude and longitude position values from the buffer and send the message to the particular number. Once the message has been send to the predefined device the GSM gets deactivated and GPS gets activated. One message will send to the traffic signal, which road accident occur that road signal will change.

**KEYWORDS:** accident; crash detection; accident response time, traffic control signals, GSM, GPS.

## I. INTRODUCTION

During the last decades, the total number of vehicles in our roads has experienced a remarkable growth, making traffic density higher and increasing the drivers' attention requirements. The immediate effect of this situation is the dramatic increase of traffic accidents on the road, representing a serious problem in most countries.

To reduce the number of road fatalities, vehicular networks will play an increasing role in the Intelligent Transportation Systems (ITS) area. Most ITS applications, such as road safety, fleet management, and navigation, will rely on data exchanged between the vehicle and the roadside infrastructure (V2I), or even directly between vehicles (V2V). The integration of sensor's capabilities on-board of vehicles, along with peer-to-peer mobile communication among vehicles, forecast significant improvements in terms of safety in the near future.

Before arriving to the zero accident objective on the long term, a fast and efficient rescue operation during the hour following a traffic accident significantly increases the probability of survival of the injured, and reduces the injury severity. Hence, to maximize the benefits of using communication systems between vehicles, the infrastructure should be supported by intelligent systems capable of estimating the severity of accidents, and automatically deploying the actions required, thereby reducing the time needed to assist injured passengers. This accident alert system in it detects the accident and location of the accident control and sends GPS coordinates to the specified mobile, computer etc.

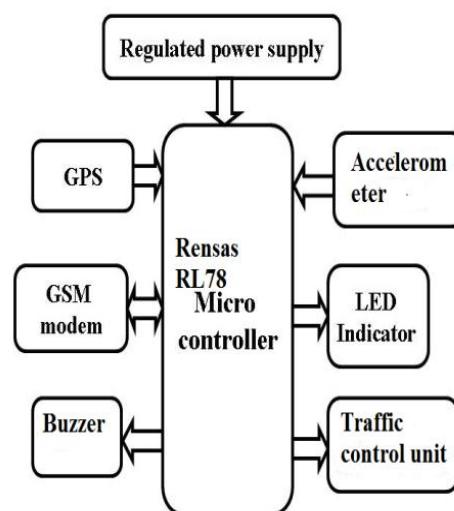

**Fig 1. Block diagram.**

## II LITERATURE SURVEY

Several researchers have been introduced in the same field of research as the ASAD system. The idea has been presented to the world at many occasions but the lack of implementation, finding the ideal location for the system or other issues have restricted the widespread uses of the idea.

The new Lexus 2014 models are equipped with a new feature called the Lexus Enform.<sup>[6]</sup> The driver, also a smartphone user, logs into the app and can use a wide range of services such as the GPS, nearby locations, assistance for directions for a phone, etc. The problem with the Lexus informs system is the pricing; informs costs about \$260 per year for a continued service from the second year of service and on the traffic control for ambulance currently they using siren so when siren start the traffic signal turns to green to ambulance so that it can easily clear the traffic.

Global System for Mobile communications (GSM: originally from Groupe Special Mobile) is the most popular standard for mobile phones in the world. Its promoter, the GSM Association, estimates that 82% of the global mobile market uses the standard.<sup>[10]</sup> GSM is used by over 3 billion people across more than 212 countries and territories.<sup>[11]</sup> Its ubiquity makes international roaming very common between mobile phone operators, enabling subscribers to use their phones in many parts of the world. GSM differs from its predecessors in that both signaling and speech channels are digital, and thus is considered a second generation (2G) mobile phone system. This has also meant that data communication was easy to build into the system.

The ubiquity of the GSM standard has been an advantage to both consumers (who benefit from the ability to roam and switch carriers without switching phones) and also to network operators (who can choose equipment from any of the many vendors implementing GSM.<sup>[7]</sup> GSM also pioneered a low-cost, to the network carrier, alternative to voice calls, the Short message service (SMS, also called "text messaging"), which is now supported on other mobile standards as well. Another advantage is that the standard includes one worldwide Emergency telephone number, 112.<sup>[4]</sup> This makes it easier for international travelers to connect to emergency services without knowing the local emergency number.

In 1982, the European Conference of Postal and Telecommunications Administrations (CEPT) created the Groupe Special Mobile (GSM) to develop a standard for a mobile telephone system that could be used across Europe<sup>[12,13]</sup> In 1987.

### III. REALTED WORK

#### A.GSM

GSM stands for Global System for Mobile Communications formerly called as *Groupe Spécial Mobile*.

This is widely used in all over the world for mobile communication. This GSM device consists of sim slot in which a sim can be inserted which has a unique number, this unique number is used for contact. This GSM device consists a unique number called imei number and this is different for each and every hardware kit.in our project the device is used for transmitting data. The data from GPS is transmitted to give mobile through this GSM itself.

One of the key features of GSM is the Subscriber Identity Module, commonly known as a SIM card. The SIM is a detachable smart card containing the user's subscription information and phone book. This allows the user to retain his or her information after switching handsets. Alternatively, the user can also change operators while retaining the handset simply by change the SIM.

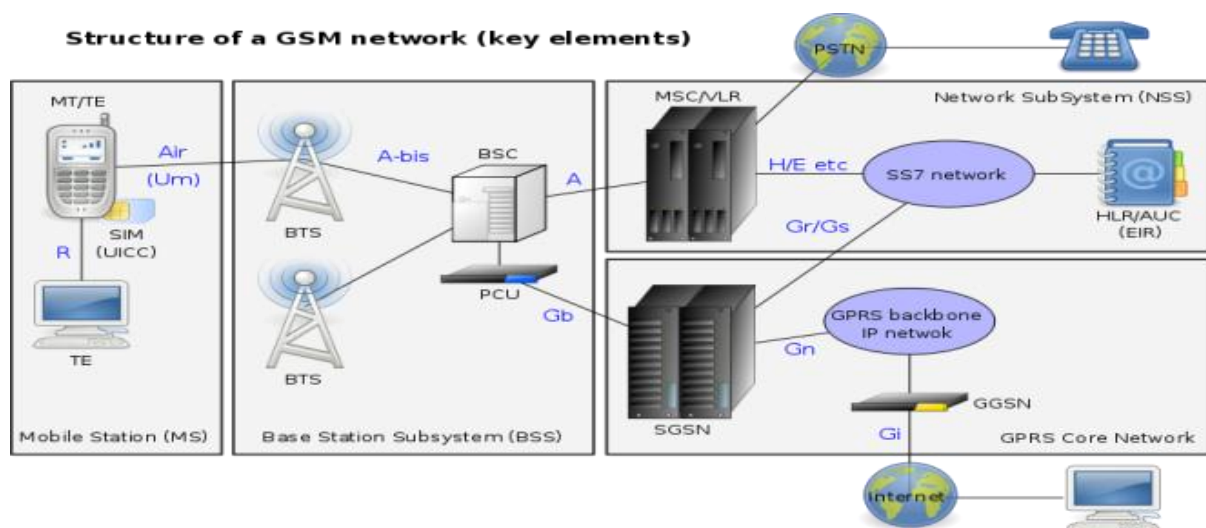

**Fig: 3.1 structure of GSM network.**

#### B. LM317 ADJUSTABLE REGULATOR

The LM117 series of adjustable 3-terminal positive voltage regulators is capable of supplying in excess of 1.5A over a 1.2V to 37V output range. They are exceptionally easy to use and require only two external resistors to set the output voltage. Further, both line and load

regulation are better than standard fixed regulators. Also, the LM117 is packaged in standard transistor packages which are easily mounted and handled.

In addition to higher performance than fixed regulators, the LM117 series offers full overload protection available only in IC's. Included on the chip are current limit, thermal overload protection and safe area protection. All overload protection circuitry remains fully functional even if the adjustment terminal is disconnected.

Normally, no capacitors are needed unless the device is situated more than 6 inches from the input filter capacitors in which case an input bypass is needed. An optional output capacitor can be added to improve transient response. The adjustment terminal can be bypassed to achieve very high ripple rejection ratios which are difficult to achieve with standard 3-terminal regulators.

Besides replacing fixed regulators, the LM117 is useful in a wide variety of other applications. Since the regulator is "floating" and sees only the input-to-output differential voltage, supplies of several hundred volts can be regulated as long as the maximum input to output differential is not exceeded, i.e., avoid short-circuiting the output.

### 1.2V–25V Adjustable Regulator

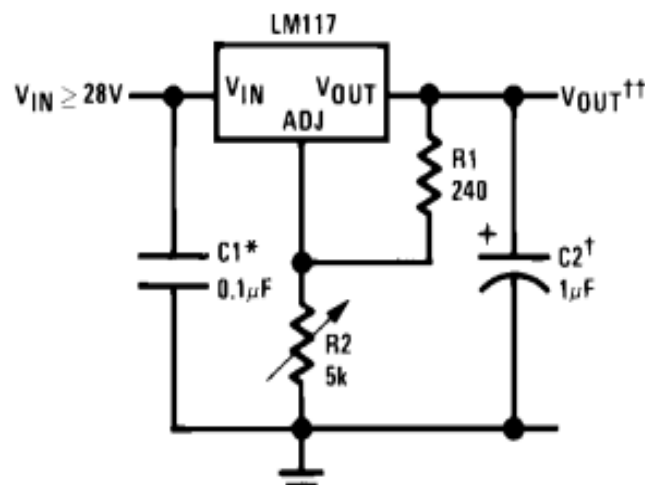

Fig 3.2. Regulator.

### C. RENESAS 64 IN IC.

General-purpose register: 8 bits × 32 registers (8 bits × 8 registers × 4 banks). ROM: 512 KB, RAM: 32 KB, Data flash memory: 8 KB. On-chip high-speed on-chip oscillator. On-chip single-power-supply flash memory (with prohibition of block erase/writing function), On-chip debug function.

Ports → Total 11 ports with 58 Input/Output Pins

- Port 0 → 0 to 6 → Total 7 pins in port 0
- Port 1 → 0 to 7 → Total 8 pins in port 1
- Port 2 → 0 to 7 → Total 8 pins in port 2
- Port 3 → 0 to 1 → Total 2 pins in port 3
- Port 4 → 0 to 3 → Total 4 pins in port 4
- Port 5 → 0 to 5 → Total 6 pins in port 5
- Port 6 → 0 to 3 → Total 4 pins in port 6
- Port 7 → 0 to 7 → Total 8 pins in port 7
- Port 12 → 0 to 4 → Total 5 pins in port 12
- Port 13 → 0, 7 → Total 2 pins in port 13
- Port 14 → 0, 1, 6, 7 → Total 4 pins in port 14

On-chip power-on-reset (POR) circuit and voltage detector (LVD) .On-chip watchdog timer (operable with the dedicated low-speed on-chip oscillator),I/O ports: 16 to 120 (N-ch open drain: 0 to 4) .

Timer → 16-bit timer: 8 to 16 channels, Watchdog timer: 1 channel.Different potential interface: Can connect to a 1.8/2.5/3 V device 8/10-bit channels .Power supply voltage: VDD = 1.6 to 5.5 V resolution A/D converter (VDD = EVDD =1.6 to 5.5 V): 6 to 26

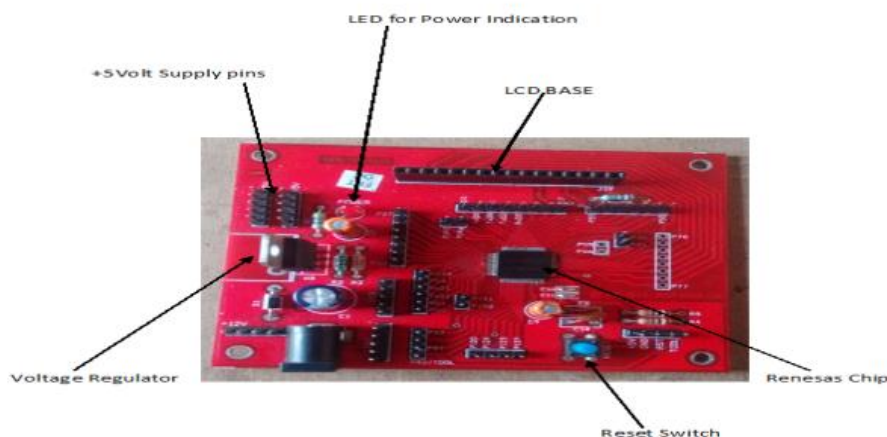

Figure of 64 pin Renesas Microcontroller Board

### D.GPS

GPS abbreviates global positioning system and this is used to detect the latitude and longitude of the particular position and it also shows the exact time.it detects these values anywhere on the earth. In our project it plays main role and it is main source of the latitude

and longitude of the vehicle to know the accident occurred location. This gadget gets the coordinates from the satellite for each and every second. This device is the main component of accident detect system.



**Fig 3.4 GPS Satellite System.**

### **E.LCD**

A **liquid crystal display (LCD)** is a flat panel display, electronic visual display, based on on Liquid Crystal Technology. LCD is the display device which is 16\*2 and it has yellow background light. This LCD is connected to microcontroller. To enable terminal latch of LCD high to low pulse is sent and RS bit is enabled .once the latch is enabled the data is transferred through the interfacing pins parallel and the LCD shows the display on it. These LCD are easy to program and they are economical tool. LCD interfacing with renesas microcontroller is very easy. Here in our accident detection and traffic control system project LCD display the output.i.e latitude and longitude of the vehicle and clearance of the traffic control.

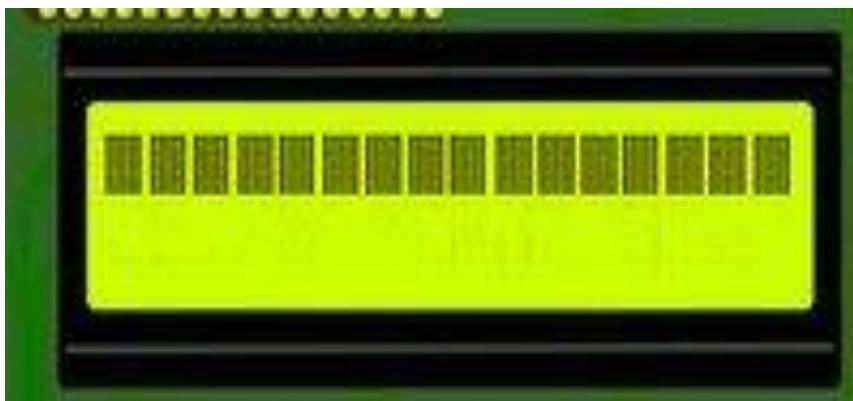
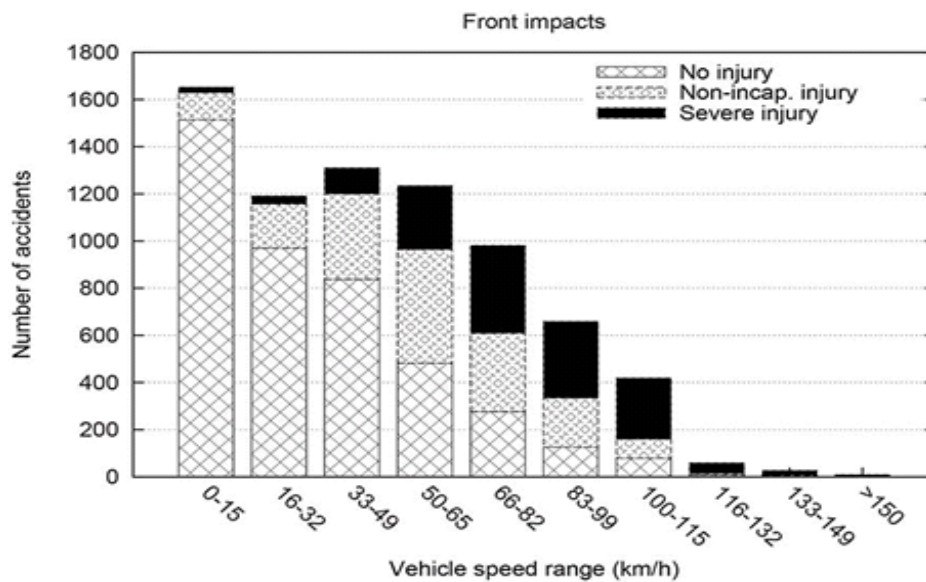

**Fig 3.5 LCD.**

**Flowchart for Displaying Message on to The LCD.**

**IV. VEHICLE UNIT**

Which highlight the influence of the speed of the vehicle and speed limit on the passengers injuries, respectively. the severity of front collisions is clearly dependent on the speed on the vehicle itself, since more than half of the registered accidents occurred at speeds greater than 80km/h resulted on severe injuries to the passengers. However, this dependence is less visible for side impacts, where the proportion between injury levels remains more stable and especially for rear-end impacts, where the almost 85% of the accidents happened when the vehicle was moving at the speeds below 15km/h. fig .4.1(c) shows the that minor accidents are the dominant type for speed limits under 60km/h and that collisions above this speed were associated with different levels of severity on the passengers injuries.



(a)

**DISTRIBUTION OF AUTOMOTIVE ACCIDENTS**

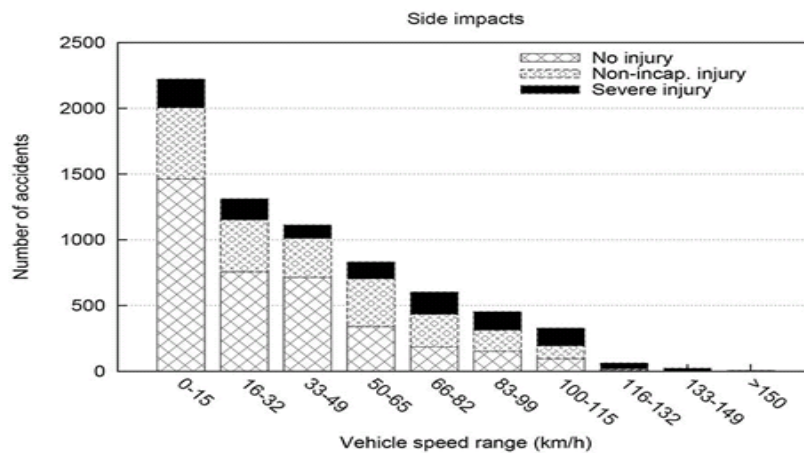

(b)



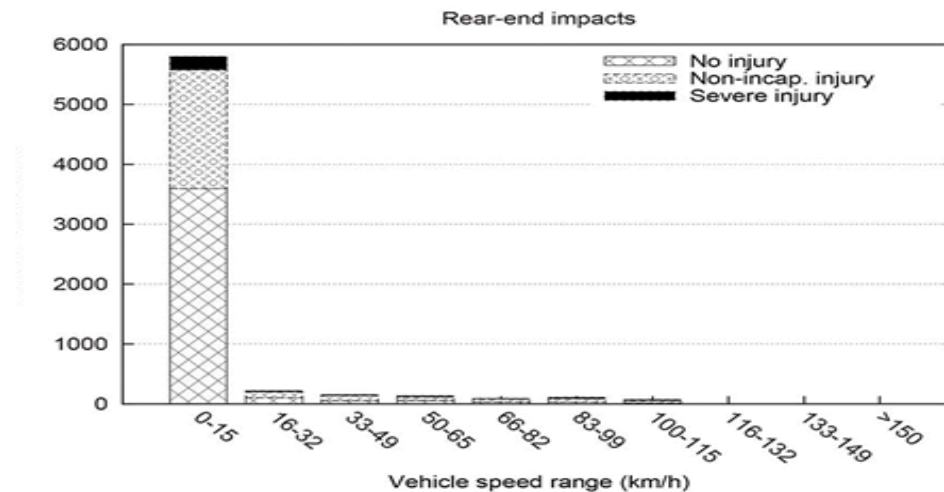

(c)

Fig4.1 speed of the vehicle and passengers injuries.

## V. RESULT

Whenever accident occurred the device send messages to the to given mobile device. i.e near police station and ambulance and traffic signal system. In traffic signal will change automatically



Fig 5.1 LCD display.

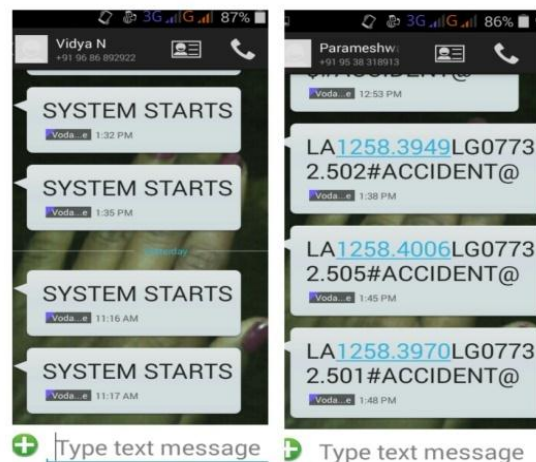

Fig 5.2 message display.

## VI. CONCLUSION

In this project, the implementation is proposed for automatic accident detection system. Thus vehicle met with an accident the alert message is send to the nearer ambulance and police station and traffic controller system by using GSM system.

Thus controlling the traffic signal in the favor of ambulance during the accidents. Thus Intelligence Traffic Light System (ITLS) if implemented in large countries with large



population like INDIA can produce better results. The ITLS is more accurate with no loss of time, but there may be a delay cost because of GSM messages since it is a queue based technique.



## VII. FUTURE WORK

To minimize the deaths and sever conditions due to accidents the GPS and GSM technologies are used where immediate action would be taken by the ambulance and police service which might reduces the severity. On the whole this system proves to be very cost effective and efficient. The experimentations and results prove that the system is easily implementable in real time. In future, the system can be interfaced with the airbag system of vehicle to prevent occupants form striking to the interior parts of the vehicle such as sterring or window. A camera can be interfaced to the controller module that takes photograph of the accident spot that makes a help for the tracking of the vehicle.

## REFERENCES

1. Eurostat: Statistical Office of the European Communities.(2012) Transport Statistics in the EU [Online]. Available: [http://epp.eurostat.ec.europa.eu/portal/page/portal/transport/data/main\\_tables](http://epp.eurostat.ec.europa.eu/portal/page/portal/transport/data/main_tables)
2. J. Miller, "Vehicle-to-vehicle-to-infrastructure (V2V2I) intelligent transportation systarchitecture," in Proc. IEEE Intell. Veh. Symp., Eindhoven, Netherlands, Jun. 2008, pp. 715–720.
3. F. Martinez, C.-K. Toh, J.-C. Cano, C. Calafate, and P. Manzoni, "Emergency services in future intelligent transportation systems based on vehicular communication networks," IEEE Intell. Transp. Syst. Mag., Oct. 2010; 2(2): 6–20.

	<p><b>Divya P. Naik</b> U.G, Department of Information Science and Engineering, M.S.E.C</p>
	<p><b>Rashmi H.R.</b> U.G, Department of Information Science and Engineering, M.S.E.C</p>

 A portrait of a woman with dark hair, wearing a red and gold patterned sari, against a blue background. The number '573' is visible in the top left corner of the image.	<p><b>Sushma N.</b></p> <p>U.G, Department of Information Science and Engineering, M.S.E.C</p>
 A portrait of a man with dark hair and a mustache, wearing a light blue and white checkered shirt, against a white background.	<p><b>Parmeshwar</b></p> <p>U.G, Department of Information Science and Engineering, M.S.E.C</p>
 A portrait of a woman with dark hair, wearing a white and red striped sari, against a blue background.	<p><b>Ganga B</b></p> <p>B.E,M.Tech,Asst. Prof Department of Computer Science and Engineering, M.S.E.C</p>