

DESIGN OF TWO-STAGE CONSTANT REDUCTION GEARBOX FOR TRANSMISSION SYSTEM OF BAJA ATV VEHICLE

Abhijeet Mishra*¹, Harsh Navale², Chetan Mali³, Ajinkya Belsare⁴ and Abhinit Hirde⁵

Department of Mechanical Engineering, Sinhgad College of Engineering, Pune.

Article Received on 19/05/2017

Article Revised on 04/06/2017

Article Accepted on 19/06/2017

***Corresponding Author**

Abhijeet Mishra

Department of Mechanical
Engineering, Sinhgad
College of Engineering,
Pune.

ABSTRACT

The Sinhgad College of Engineering Baja Team, every year, designs, builds, tests and races an off road vehicle. Typically, every season before this year, the Baja Team used an OEM gearbox straight from a commercial vehicle which satisfied the gear ratios calculated during the design phase. The aim of this project is to develop a customized

Gearbox drivetrain which was efficient, lightweight and durable while at the same time conform to the design requirement to integrate with all the subsystems deftly. A gearbox with a cageless differential was found to satisfy all the requirements. In this study, a cageless differential was designed and analysed. The modelling of the gearbox was done using CATIA and the analysis was carried out in ANSYS workbench. The gearbox testing on the Baja vehicle was found to be effective.

KEYWORDS: Two stage constant reduction gearbox, Cage-less differential, Transmission system for Baja Atv.

INTRODUCTION

Sae Baja India is an international competition where teams have to design and build an ATV. The teams are provided with a Briggs & Stratton 10 HP engine which has to be used in stock condition. The transmission along with the drive-train is one of the most critical systems in the car. Their purpose is to transfer the power generated by the engine to the ground with minimum losses.

A good transmission system provides the car with enough torque to overcome all the obstacles that can be encountered in a demanding terrain. At the same time, the car should be able to achieve a considerable high speed. Thus the torque and speed requirements must be balanced well. If the torque available at the wheels is more than what is required in the harshest conditions, then we will be left with torque that will never be used and a very low top speed. Similarly, very high top speed will result in low torque and the vehicle may not be able to navigate over tough terrains.

Thus the design of the transmission system is a balancing act between torque and high speed.

AIM

The aim of the transmission team is to provide a car which provides high torque as well as moderately high top speed.

The team has tried to achieve the following objectives while designing the transmission system.

- 1) The car must be able to climb a 40° slope. The objective of the team is to provide the car with far more torque to facilitate loss of traction. Also, according to Chris Milet, who spent a lot of time designing off-road as well as asphalt racing tyres at Goodyear, the tread lugs on off-road tires dig into the ground when the vehicle is trying to overcome obstacles. They, thus act as a lever to overcome the obstacles. Thus the team has planned to provide 20% extra torque so that the wheel can overcome sudden bumps and climb over rocks and steps. The extra torque will be transferred from the lugs to the ground at this time.

The minimum torque that is required to propel the vehicle over a 40° slope can be calculated as follows.

We will be using the following equations in our calculations.

- a. $f - mg\sin\theta = ma$
- b. $r\alpha = a$
- c. Torque Equation: $I\alpha = \tau - f*r - RR*r$
- d. RR (Rolling Resistance) = $0.005 * m*g$

Here f = friction available on ground

m = Mass of vehicle (240kg with driver)

r = Radius of tyre (11.5 inch)

a = acceleration of vehicle ($a = 0$; since it should just climb 40° slope)

τ = Max torque at wheels

α = angular acceleration of tyre

($\alpha = 0$; since $a = 0$)

I = Moment of Inertia of rotating parts

($M_{\text{rotating parts}} \cdot r^2 = 14(\text{Mass of 2 wheels}) \cdot (0.2921)^2$)

Solving these equations, we get $\tau = 541$ N-m

Adding an additional 10% to account for losses, $\tau_{\text{new}} = 595$ N-m

Adding another 20% to overcome demanding obstacles, $\tau_{\text{max}} = 714$ N-m

Therefore, we need to at least have 714N-m of torque available at the wheels to make the vehicle capable of navigating any terrain what-so-ever.

Thus the maximum reduction of the vehicle should be around 37: 1 (714/ 19.2).

- 2) The rules suggest that the ATV must have a maximum speed around 60kmph. In a 150 ft straight, where the acceleration of the vehicle is checked, we need to have the maximum speed at the end of the straight. The aim is to cover the 150ft in about 5.5 sec. We selected that a speed of over 50kmph is desirable considering our previous experiences.

Old design

Our old design consisted of a Piaggio Ape Gearbox mated to the engine. The Gear box provided a maximum reduction of 52:1 and a minimum reduction of 11:1.

The drawbacks of the old design were as follows:

1. Provided over 998N-m of torque. Even though the vehicle was heavier at 350kg, this amount of torque available at the wheels meant that there was always excess torque available.
2. The top speed of the vehicle was 41kmph. This was very slow considering the competition.
3. Less Clutch Stall Time

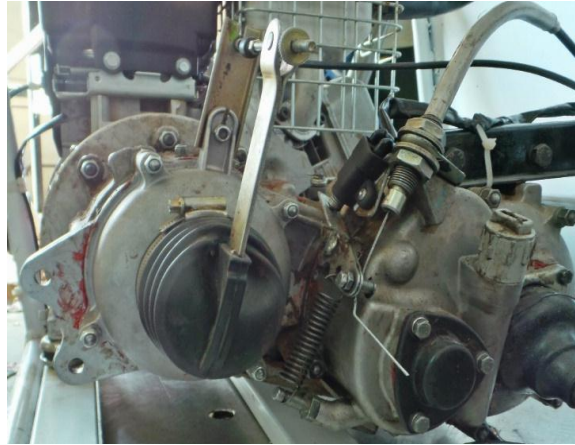

Figure 1: Transmission System on Previous Car.

New design

The design for the 2016 car saw several changes. The most notable being that the manual Transmission was substituted by a CVT coupled with a self-designed Two Stage Constant Reduction Gearbox. This was done so that the team had the freedom to choose their own value of top speed and torque. This cannot be done with an off-the-shelf gearbox. Secondly, the freedom to build our own gearbox allowed us to reduce the weight of the transmission as the gearbox has been highly optimised.



Figure 2: New Transmission System for Car.

Continuously Variable Transmission (Cvt)

This year, the team decided to use a CVT rather than a manual transmission. The advantages of CVT were as follows

1. No Gear changes required. The CVT changes the ratios on its own automatically.
2. Better Acceleration
3. Simpler to Drive

The Team had to make a choice between CV Tech and Polaris P-90 CVT clutches.

The following advantages weighed in the favour of Polaris P-90:

- 1) higher tuning option available.
- 2) Better Performance.
- 3) Availability of Polaris Technicians in India.
- 4) Higher Ratio of Gear Changes (3.83:1 to 0.76:1).

The following limitations of the P-90 Clutch were:

1. Expensive.
2. The CVT has to be machined upon to mate it to the gearbox and Engine.

Considering the advantages, the decision to work with Polaris P-90 was taken. The team felt that even though there were a few disadvantages, the P-90 would give superior performance which is the main consideration while building a buggy for Baja.

Graph for Engine RPM vs. Vehicle Speed in km/hr. for Briggs & Stratton 10HP engine running a Polaris P-90 CVT is shown below.

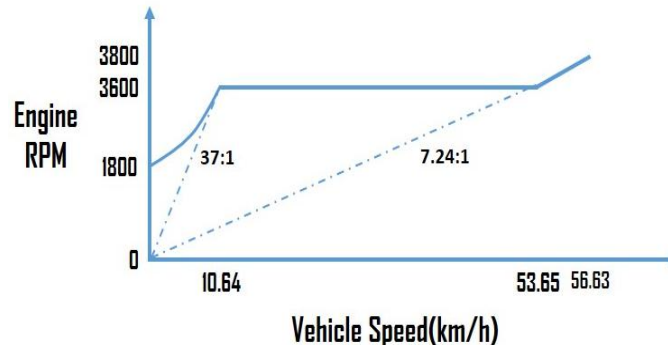

Figure 3: Engine RPM vs. Vehicle Speed.

Gearbox

The team decided to design and manufacture a gearbox for the buggy. This allowed the team to decide their own customisable reduction ratio and also reduced the weight of the gearbox.

As decided, the reduction ratio of the vehicle needs to be about 37:1.

The Polaris P-90 provides a maximum reduction of 3.83:1. Therefore the reduction of the gearbox must be in about 9.66:1.

After Several Calculations and considering the space available to fit the gearbox, it was decided that the team will design a Two Stage Constant Reduction Gearbox. The reduction Ratio of the first and second stage was decided to be 2.5:1 and 3.88:1 respectively.

This was done to reduce the weight of the gearbox. However the ratio of the second stage was chosen to be on the higher side so that the differential can be fitted into the Gear.

These reduction ratios help the vehicle achieve the following characteristics:

1. The maximum torque is 715N-m @ 2800 rpm.
2. The maximum speed of the vehicle is 56kmph @ 3800 rpm.

The team also decided to use a cage-less differential. This was done so that the Vertical axis of the gearbox aligns with the Vertical axis of the vehicle. This allowed a reduction of over 1.5 kgs in weight as the cage of the differential was totally eliminated.

All the gears are highly customised to reduce the weight.

The gearbox casing is made of aluminium 6061 so as to reduce the weight. The casing only weighs 3kgs.

Geometry and space considerations

The transmission is one of the many subsystems on the vehicle. They all have to work in tandem to achieve the best possible results. Only when all the subsystems work in harmony, will the best characteristics of the vehicle be available to see.

Thus the Brakes and the Suspension teams gave us a few points that we had to adhere to

1. The Engine must be as low as possible to keep the centre of mass as low as possible. This prevents the vehicle from turning turtle when titled at a high degree slope.
2. The Output Shaft of the Gearbox must be at a distance of 18" from the firewall and at a height of 94 mm from the lower member of the roll cage. This helps to restrict the wheelbase to 58.5". This improves the vehicle dynamics and helps in integrating the transmission with the wheelbase. The manoeuvrability also improves.

The team decided that the placement of the gearbox and engine is as follows:

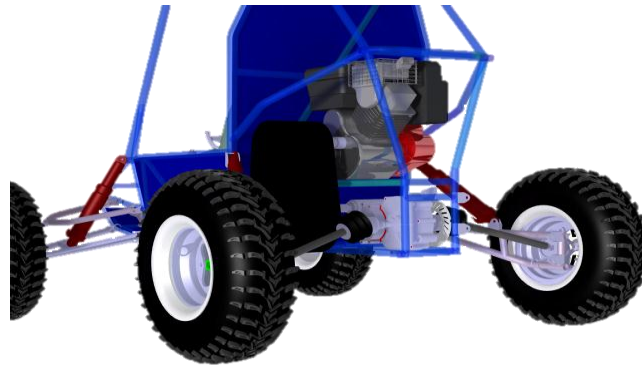

Figure 4: Space available at the back of the ATV.

While we compromise on the height of the engine, and thus increase the height of the Centre of Mass of the car, we satisfy the other two conditions. This advantage of improving the vehicle characteristics far outweighs the disadvantages of increasing the height by a few inches.

Salient Features of the Gearbox

1. The Gearbox weighs only 10kgs. This is a reduction of over 10kgs from the previous gearbox.
2. All the Gears are made of 20MnCr5. This is done to reduce the size and weight of the gears.
3. EP-90 oil is used in the gearbox. This oil was selected after taking into account the forces acting on the gearbox. The heat dissipation characteristics of this oil are far superior to other automotive oils. The oil also maintains its viscosity at higher temperatures.
4. The cage-less differential centralises the gearbox. Thus torque steer is totally eliminated. The suspension also has symmetry on both sides.

Design Calculations

Gearbox Calculations

1st Stage reduction

Number of teeth on pinion (Z_p) = 20

Number of teeth on gear (Z_g) = 50

Speed of Pinion (N_p) = 5000RPM

Gear Ratio = 2.5

$$\sigma_{bp} = S_{ut} / 3$$

$$= 1100 / 3$$

$$=366.66\text{N/mm}^2$$

$$\sigma_{bg} = S_{ut}/3$$

$$=1100/3$$

$$=366.66\text{N/mm}^2$$

$$\text{Lewis Form Factor (Y)} = 0.484-(2.87/Z)$$

$$\therefore Y_p = 0.484-(2.87/Z_p)$$

$$=0.484-(2.87/20)$$

$$=0.3405$$

$$\therefore Y_g = 0.484-(2.87/Z_g)$$

$$=0.484-(2.87/50)$$

$$=0.4266$$

$$\sigma_{bp} \times Y_p < \sigma_{bg} \times Y_g$$

\therefore As Pinion is weak it is necessary to design pinion.

Beam Strength:

$$F_b = \sigma_{bp} \times b_p \times m \times Y_p$$

$$=366.66 \times 10\text{m} \times m \times 0.3405$$

$$=1248.497\text{m}^2 \text{ N}$$

$$\text{Wear Strength (F}_w) = d_p \times b \times Q \times K$$

$$= 20\text{m} \times 10\text{m} \times 1.4285 \times 6.76$$

$$= 1931.332\text{m}^2 \text{ N}$$

Where,

$$1. d_p = m \times Z_p = 20\text{m}$$

$$2. Q = 2 \times Z_g / (Z_g + Z_p)$$

$$= 2 \times 50 / (50+20)$$

$$= 1.4285$$

$$3. K = 0.16 \times (\text{BHN}/100)^2$$

$$= 0.16 \times (650/100)^2$$

$$= 6.76 \text{ N/mm}^2$$

$F_b < F_w$, As Gear Pair is weak in bending hence it is designed for safety against bending.

Effective Load

$$V = \pi \times d_p \times n_p / 60 \times 1000$$

$$= \pi \times 20 \times m \times 5000/60 \times 1000$$

$$= 5.2359 \text{ m/sec}$$

$$F_t = P/V$$

$$= 7500/5.2359 \text{ m}$$

$$= 1432.3944/\text{m}$$

$$K_v = 6/6+V$$

$$= 6/6+5.2359 \text{ m}$$

$$F_{\text{eff}} = \{K_a \times K_m \times F_t\} / K_v$$

$$= \{1.3 \times 1.3 \times (1432.3944/\text{m})\} / (6/6+5.2359 \text{ m})$$

$$= 403.4577 \times (6+5.2359 \text{ m}) / \text{m}$$

Calculating Module

$$F_b = \text{FOS} \times F_{\text{eff}}$$

$$1248.487 \times \text{m}^3 = 1.5 \times 403.4577 \times (6+5.2359 \text{ m})$$

$$\text{m} = 1.9$$

$$\text{m} \approx 2$$

Checking gear pair for wear strength

$$F_w = \text{FOS} \times F_{\text{eff}}$$

$$7725.328 = \text{FOS} \times 3322.8372$$

$$\text{FOS} = 2.32$$

$$\text{Diameter of pinion} = \text{m} \times Z_p$$

$$= 2 \times 20$$

$$= 40 \text{ mm}$$

$$\text{Diameter of Gear} = \text{m} \times Z_g$$

$$= 2 \times 50$$

$$= 100 \text{ mm}$$

1) *Second Stage Gear Pair*

$$\text{Number of teeth of pinion } (Z_p) = 18$$

$$\text{Number of teeth of gear } (Z_g) = 70$$

$$\text{Speed of pinion } (n_p) = 2000 \text{ RPM}$$

$$\text{Gear Ratio} = 3.8$$

$$\sigma_{bp} = S_{ut}/3$$

$$= 1100/3$$

$$= 366.66 \text{ N/mm}^2$$

$$\sigma_{bg} = S_{ut}/3$$

$$=1100/3$$

$$=366.66\text{N/mm}^2$$

$$\text{Lewis Form Factor (Y)} = 0.484 - (2.87/Z)$$

$$\therefore Y_p = 0.484 - (2.87/Z_p)$$

$$= 0.484 - (2.87/18)$$

$$= 0.3245$$

$$\therefore Y_g = 0.484 - (2.87/Z_g)$$

$$= 0.484 - (2.87/70)$$

$$= 0.443$$

$$\sigma_{bp} \times Y_p < \sigma_{bg} \times Y_g$$

\therefore As Pinion is weak it is necessary to design pinion.

Beam Strength:

$$F_b = \sigma_{bp} \times b_p \times m \times Y_p$$

$$= 366.66 \times 10 \text{m} \times m \times 0.3245$$

$$= 1190.0348 \text{m}^2 \text{ N}$$

$$\text{Wear Strength (F}_w) = d_p \times b \times Q \times K$$

$$= 18 \text{m} \times 10 \text{m} \times 1.590 \times 6.76$$

$$= 1934.712 \text{m}^2 \text{ N}$$

Where,

$$d_p = m \times Z_p = 18 \text{m}$$

$$Q = 2 \times Z_g / (Z_g + Z_p)$$

$$= 2 \times 70 / (70 + 18)$$

$$= 1.590$$

$$K = 0.16 \times (\text{BHN}/100)^2$$

$$= 0.16 \times (650/100)^2$$

$$= 6.76 \text{ N/mm}^2$$

$F_b < F_w$, As Gear Pair is weak in bending hence it is designed for safety against bending.

Effective Load

$$V = \pi \times d_p \times n_p / 60 \times 1000$$

$$= \pi \times 18 \times m \times 2000 / 60 \times 1000$$

$$= 1.88495 \text{m m/sec}$$

$$F_t = P/V$$

$$= 7500 / 1.88495 \text{m}$$

$$=3978.8735/m$$

$$K_v=6/6+V$$

$$=6/6+1.88495m$$

$$F_{eff} = \{K_a \times K_m \times F_t\} / K_v$$

$$= \{1.3 \times 1.3 \times (3978.8735/m)\} / (6/6+1.88495m)$$

$$=1120.7160 \times (6+1.88495m) / m$$

Calculating Module:

$$F_b = FOS \times F_{eff}$$

$$1190.0348 \times m^3 = 1.5 \times 1120.7160 \times (6+1.88495m)$$

$$m = 2.46$$

$$m \approx 2.5$$

Checking gear pair for wear strength

$$F_w = FOS \times F_{eff}$$

$$12091.95 = FOS \times 4802$$

$$FOS = 2.51$$

$$\text{Diameter of pinion} = m \times Z_p$$

$$= 2.5 \times 18$$

$$= 45 \text{ mm}$$

$$\text{Diameter of Gear} = m \times Z_g$$

$$= 2.5 \times 70$$

$$= 175 \text{ mm}$$

2) Differential

The differential gears are exact replica of Tata Zip. This was done because the drive shafts used are OEM parts. To mate the driveshaft and bevel gears properly, the replicas had to be used. The crown gear was optimized to reduce weight.

The Cross pin in the centre of the differential gears and crown gear have been tested on ANSYS and Hypermesh.

The results are as follows

1) Crown Gear

Material: 20MnCr5

Force applied: Forces applied by intermediate gear (pinion) on the crown gear are $F_1 = 3230$ N, $F_2 = 8888$ N. Torque of 800 Nm is applied.

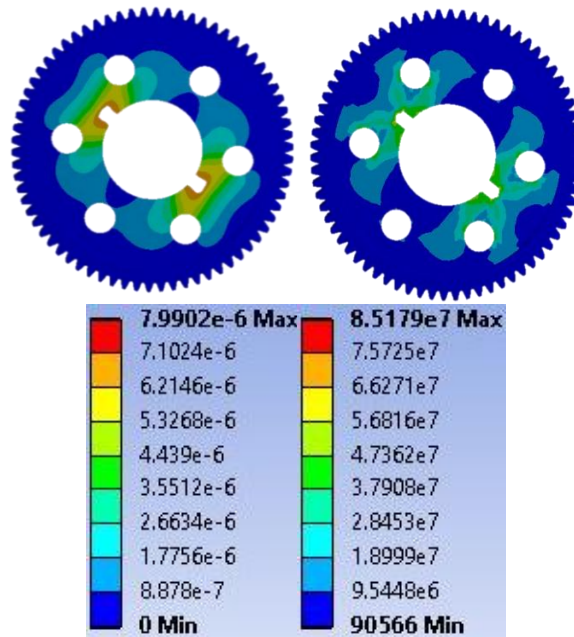

Figure 5: Displacement | Stress of Crown Gear.

2) Cross Pin

Force applied: Torque of 800 Nm transmitted by the crown gear is applied on the cross pin. $F_1 = 7024$ N. $F_2 = 10285$ N.

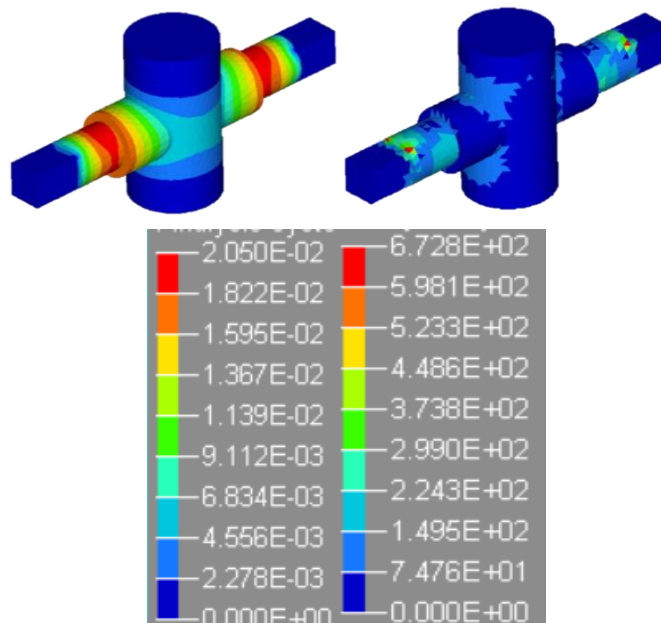

Figure 6: Displacement | Stress.

Max displacement	Max stress	FOS
0.02 mm	672.8 MPa	1.47

Shafts

1) Input Shaft

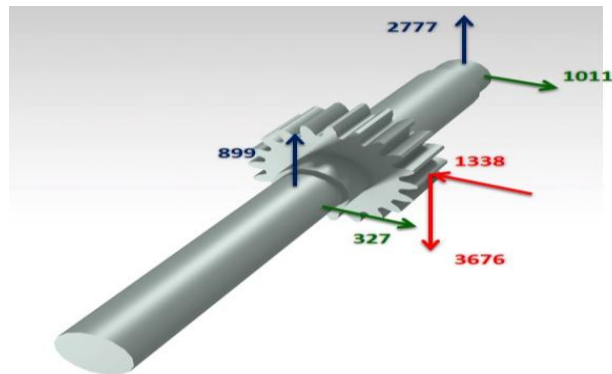

Figure 7: Input Shaft For a vertical load.

$$(R_{Av} \times 0) + (3676 \times 68) = (R_{Bv} \times 90)$$

$$R_{Bv} = 2777.42\text{N}$$

$$R_{Av} = 898.58\text{N}$$

For horizontal load,

$$(R_{Ah} \times 0) + 1338 \times 68 = (R_{Bh} \times 90)$$

$$R_{Bh} = 1010\text{N}$$

$$R_{Ah} = 328\text{N}$$

$$M_e = \sqrt{25.273^2 + 69.4355^2}$$

$$= 73.89\text{Nm}$$

$$T_e = (1.5)\sqrt{M^2 + T^2}$$

$$= 157.9$$

$$\Gamma_{\max} = 0.18 S_{ut}$$

$$= 0.18 \times 1100$$

$$= 198 \text{ MPa}$$

$$\Gamma_{\max} = \frac{16Te}{\pi d^3}$$

$$198 = \frac{16 \times 157.9 \times 10^3}{\pi d^3}$$

$$\therefore d = 15.95\text{mm}$$

We have selected $d=17\text{mm}$ near bearing and 20mm at mainshaft.

2) Intermediate Shaft

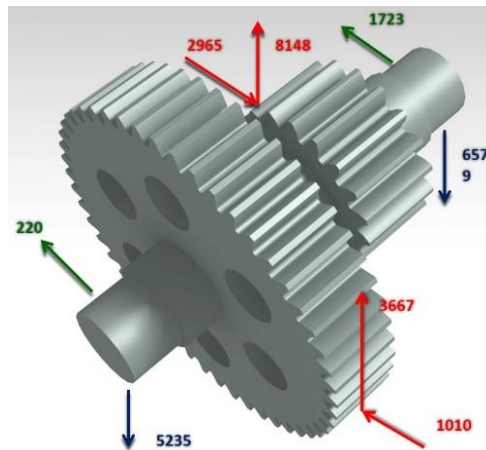

Figure 8: Intermediate Shaft for Vertical Loading.

$$(R_{Av} \times 0) - (8148 \times 34) - (3667 \times 76.5) + (R_{Bv} \times 106.5) = 0$$

$$\therefore R_{Av} = 6579\text{N}$$

$$\therefore R_{Bv} = 5235.28\text{N}$$

For Horizontal Loading,

$$(R_{Ah} \times 0) - (2965 \times 34) + (3667 \times 76.5) - (R_{Bh} \times 106.5) = 0$$

$$\therefore R_{Ah} = -1723.06\text{N}$$

$$\therefore R_{Bh} = -220.41\text{N}$$

Bending Moment at Point A

$$\text{Vertical} = 223.6 \text{ Nm}$$

$$\text{Horizontal} = 56.58 \text{ Nm}$$

Bending Moment at point B

$$\text{Vertical} = 157.0584 \text{ Nm}$$

$$\text{Horizontal} = 6.6 \text{ Nm}$$

As bending moment at point A is higher, the shaft is designed according to bending moment at A.

$$\text{Equivalent Moment } (M_e) = \sqrt{223.6^2 + 58.58^2}$$

$$= 230\text{Nm}$$

$$T_e = (1.5)\sqrt{M^2 + T^2}$$

$$\therefore T_e = 1.5(\sqrt{230^2 + 187^2})$$

$$= 1.5 \times 296.42$$

$$= 444$$

$$\Gamma_{\max} = 198 \text{ MPa}$$

And,

$$\Gamma_{\max} = \frac{16Te}{\pi d^3}$$

$$\therefore 198 = \frac{16 \times 444 \times 10^3}{\pi d^3}$$

$$\therefore d = 22.52 \text{ mm}$$

Shaft Size was taken as 25mm.

The Complete Gear Train was thoroughly tested in ANSYS. The results were as follows

Force applied:

First shaft

Torque = force experienced x radius

$$80 = F \times 20 \times 10^{-3}$$

$$F = 4000 \text{ N. (Radial)}$$

$$F = 4000 \times \tan 20 = 1455 \text{ N (axial)}$$

Second shaft

Torque = force experienced x radius

$$T = 4000 \times 50 \times 10^{-3}$$

$$T = 200 \text{ Nm}$$

$$F = 8880 \text{ N (Radial)}$$

$$F = 3230 \text{ N (Axial)}$$

Third shaft

Torque = Force x Radius

$$T = 8880 \times 0.0875$$

$$T = 777 \text{ Nm.}$$

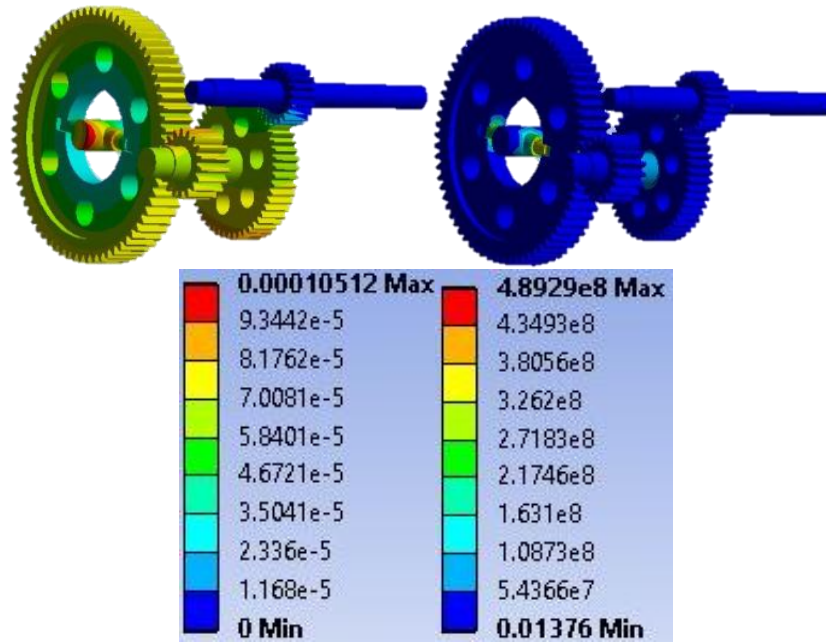

Figure 8: Displacement | Stress of entire gear train.

Max displacement	Max stress
0.105 mm	489 MPa

Bearing Selection

The Bearings are an integral part of any gear-box design. They reduce the friction between The Shaft and the Casing. This reduces wear and tear. It also helps in improving the efficiency.

Since we are designing a gearbox to be used in an automobile, the bearing life must be at least 50 million revolutions. However, since the car is an off-road vehicle and will be used only occasionally, even 30 million revolutions can be considered safe. However, we have only used the lesser life bearings, when there is a saving of weight and factor of availability of bearing.

Since the load on the shafts is not same on both ends, one can technically use different bearings on both sides. However, since that will reduce the symmetry of the casing, we chose otherwise and have used the same bearing on both sides. In doing so, we have considered the end where the force acting is greater.

1) Bearing for Shaft 1

Required inner diameter of shaft = 17mm

Maximum Radial Load on one bearing = 2955N

Considering the life of 50 million revolutions for the bearing

$$C=P (L_{10})^{1/3}$$

Where,

P= Radial Load on Bearing

L₁₀=Life of bearing expressed in millions of revolutions

C=Basic Dynamic Load Rating

$$\therefore C = 2955 (50)^{1/3}$$

$$= 10866.313\text{N}$$

For Bearing 6303, C = 13500N

\therefore Bearing 6303 was selected for the operation

2) *Intermediate Shaft Bearing*

Required inner diameter of Bearing = 22mm

Maximum Radial Load on one bearing = 6800N

Considering the life of 20 million revolutions for the bearing

$$C=P (L_{10})^{1/3}$$

Where,

P= Radial Load on Bearing

L₁₀=Life of bearing expressed in millions of revolutions

C=Basic Dynamic Load Rating

$$\therefore C = 6800 (20)^{1/3}$$

$$= 18458.039\text{N}$$

For Bearing 63/22, C=18600N

\therefore Bearing 63/22 was selected for the operation.

3) *Bearings for Bevel Gears*

Required inner diameter of bearing = 30mm

Maximum Radial Load on one bearing = 4333N

Considering the life of 50 million revolutions for the bearing

$$C=P (L_{10})^{1/3}$$

Where,

P= Radial Load on Bearing

L₁₀=Life of bearing expressed in millions of revolutions

C=Basic Dynamic Load Rating

$$\therefore C = 4333 (50)^{1/3}$$

$$= 15962\text{N}$$

For Bearing 6206, $C=20300$

\therefore Bearing 6206 was selected for the operation.

Casing

The casing needs to be light-weight. The main aim while designing the casing was that it should be light-weight as well as strong enough to sustain the forces acting on it and transfer them to the chassis.

While designing the gearbox, P.S.G. Design data book was referred. The clearances and distance between the gearboxes were chosen accordingly.

The gearbox was then tested in Ansys, and when we felt that the gearbox was safe, it was manufactured. Gearbox was mounted on the roll cage of the vehicle using suitable mounts which were tested on Ansys.

CAD of the design



Figure 9: Casing of Gearbox.

The Gear Train casing was tested in ANSYS. The results were as follows.

Material: Aluminium 6061 T6

Force applied: The reaction forces obtained from the shafts (all forces in vertical plane) were applied on the casing to check if the casings of gear train were safe.

Shaft 1: $F_1 = 880\text{ N}$ (axial)

$F_2 = 3579\text{ N}$ (radial)

Shaft 2: $F_1 = 5505\text{ N}$ (axial)

$F_2 = 448\text{ N}$ (radial)

Shaft 3: $F_1 = 4933\text{ N}$ (axial)

$F_2 = 1795\text{ N}$ (radial)

Casing 1

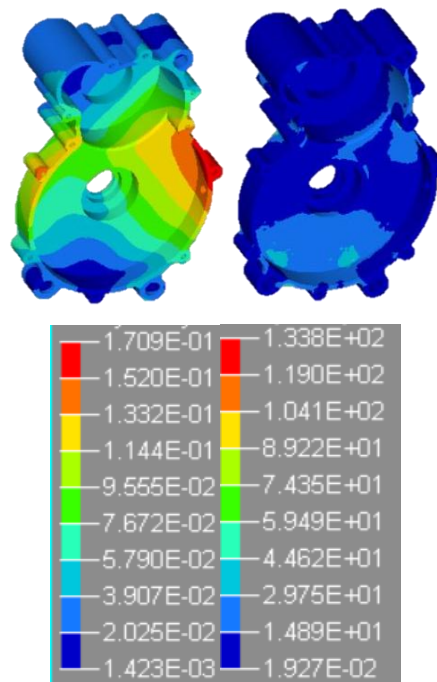

Figure 10: Displacement | Stress of Casing Part 1.

Max displacement	Max stress	FOS
0.17 mm	133.3 MPa	2.3

Casing 2

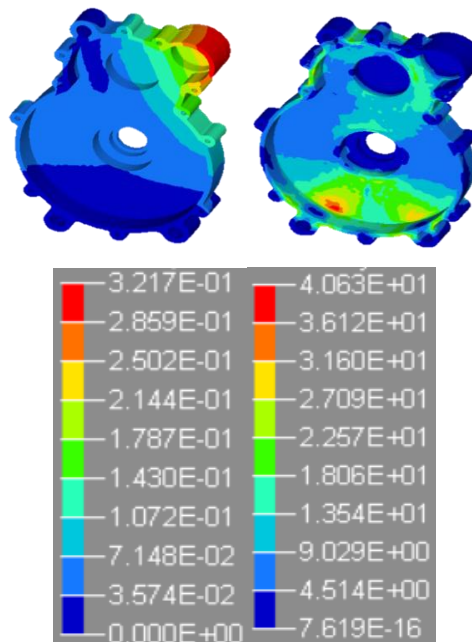

Figure 11: Displacement | Stress of Casing 2.

Max displacement	Max stress	FOS
0.32 mm	40.6 MPa	7.75

Gearbox mounts

Force applied: Forces acting on gearbox mounts were the reaction forces acting due to bearing load.

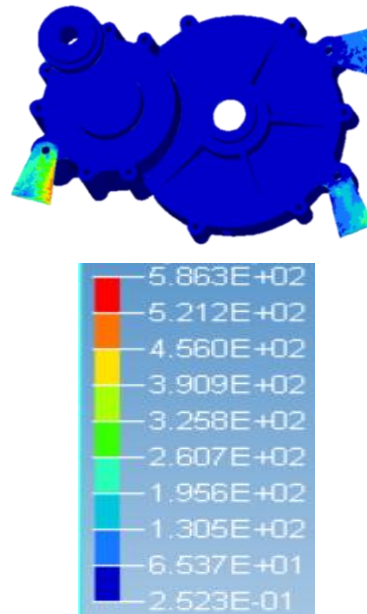

Figure 11: Stress on Gearbox Mounts.

Max stress	FOS
586 MPa	1.19

Adapters

Engine to CVT adapter

Engine was connected to CVT driving clutch using a well-designed adapter/sleeve. The Engine Shaft goes into the hole in the sleeve. The primary pulley is mounted on the long shaft. The power is transferred to the primary pulley using threads. The sleeve was tested using ANSYS. The results were as follows.

Material: EN24

Force applied: Torque of 20 Nm was applied on sleeve 2.

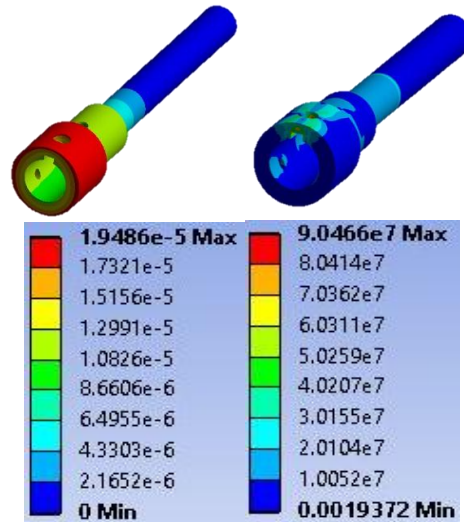

Figure 12: Displacement | Stress of Engine to CVT adapter.

Max displacement	Max stress	FOS
0.0194 mm	90.46 MPa	5.16

CVT to Gearbox adapter

CVT driven clutch was connected to gearbox using a sleeve / adapters. The secondary pulley is moped on the adapter. Splines are made on the adapter using EDM. The Secondary pulley transfers power through spines. The design of sleeve was tested on ANSYS. The results were as follows.

Material: EN24 Force applied: Torque of 80 Nm was applied on sleeve 1.

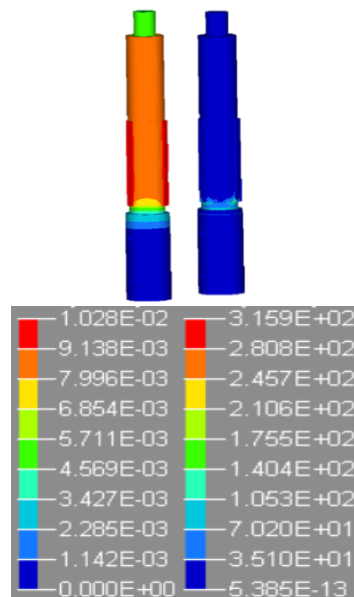

Figure 12: Displacement|Stress of CVT to Gearbox.

Max displacement	Max stress	FOS
0.012 mm	315.9 MPa	1.14

CONCLUSION

The aim of the project was to design an automatic transmission for a mini BAJA ATV. Since the team decided to employ a Continuously Variable Transmission, it was imperative to couple it to a two stage constant reduction gear box. This is necessary because the CVT does not provide the required reduction, even though it provides a good range of speeds. Thus the output from the CVT must be further reduced to achieve the required speed of the vehicle. The entire system was designed, built and then tested on the BAJA ATV for over 500 Km. The system showed no fatigue. It achieved all the performance parameters it was designed for. However, the system can be further improved if a Gaged CVT is used instead of the Polaris. The Gaged CVT allows for higher customisation and also provides better acceleration. It also does not require the adaptors to mate with the engine and gearbox. This reduces further weight of the entire system. Using better materials for the gears can also reduce the weight and size of the gearbox.

REFERENCES

1. Aaen, O., Olav Aaen's Clutch Tuning Handbook, AAEN Performance, 2007.
2. Pancheri, D., "Clutching 101 How a CVT Works," Idaho Falls, Indiana, 2011.
3. Gillespie, Thomas, Fundamentals of Vehicle Dynamics, SAE International, 1992.
4. Dr. Singh, K., Automobile Engineering, Standard Publishers Distributors, 2012; 1.
5. Dr. Singh, K., Automobile Engineering, Standard Publishers Distributors, 2012; 2.
6. Final Design Report, BAJA Gear Reduction, University of Michigan, 2012.
7. Martinez, L., S.A.E BAJA Project: Transmission Design, University of San Diego.
8. SAE International, "2015 Collegiate Design Series, Baja SAE Rules", 2015.
9. Khurmi, R., A Textbook of Machine Design, S Chand Publications, 2005.