

EFFECTS OF CORROSION TO THE CRACKS INDICES OF REINFORCED CONCRETE STRUCTURES EXPOSED TO MARINE ENVIRONMENT

Cecielle N. Dacuan^{*a}, Hana Astrid Canseco, PhD^b and Virgilio Abellana, PhD^c

^{a,c}University of San Carlos, Cebu, Philippines, ^bCebu Technological University.

Article Received on 16/04/2022

Article Revised on 06/04/2022

Article Accepted on 27/05/2022

*Corresponding Author

Cecielle N. Dacuan

University of San Carlos,
Cebu, Philippines.

ABSTRACT

The entire cracking process of concrete induced by corrosion is of great importance for the performance analysis and service life prediction of reinforced concrete structures. A study on the correlation of the cracking behavior of concrete due to induced corrosion, represented by crack indices to design parameters (e.g., concrete cover and main diameter ratio, concrete cover thickness, and steel reinforcement diameter) was conducted to assess the durability and serviceability of structures generally exposed to aggressive marine environments. A total of 54–300 mm × 300 mm × 300 mm concrete specimens with a design concrete strength of 28MPa at 28-days were cast. Corrosion was induced by immersing the specimens in a simulated environment with a 5% sodium chloride solution. It was verified from the experiments that specimens with higher crack frequencies deteriorated more than those with lower crack frequencies. Moreover, the depth of the cracks was highly correlated with the decrease in the rebar diameter. A more significant reduction in the diameter of the steel reinforcement occurred when the width of the cracks increased. The concrete cover thickness significantly influenced the reduction in the steel reinforcement mass. The concrete cover thickness and corrosion rates were positively correlated with the actual mass of rust or corrosion products.

KEYWORDS: *Corrosion rates, crack depths, crack frequency, crack geometry, crack width, percent mass loss, mass loss rate, coincident cracks, intersecting cracks.*

1. INTRODUCTION

Cement is widely used in the construction industry owing to its low cost and availability.^[27] It has been used in the construction of infrastructure, historical monuments, power plants, bridges, air ports, and sea port facilities.^[15] However, a substantial number of concrete structures experience considerable deterioration before they reach their design service life.^[29] The durability of reinforced concrete structures has been a considerable concern in structural engineering because premature deterioration affects the structural integrity and safety of structures.^[20, 29]

The environmental conditions in which the structures are exposed influence the durability of most reinforced concrete structures.^[18] Structures and facilities exposed to dynamic marine environments are subject to deterioration over their lifetimes. The most recognized deterioration mechanism of structures disclosed in aggressive marine environments is the corrosion of reinforcing steel deformed bars.^[2] Over the past decades, corrosion has become a global problem in the construction industry.^[27] It has been perceived as a detrimental factor in the deterioration of the serviceability and durability of reinforced concrete structures, particularly those exposed to marine environments.^[18]

The deterioration of structures has a considerable cost associated with it.^[29] Corrosion-damaged structures require sufficient amounts for repair and maintenance.^[18] Ignoring the problem of corrosion poses a penalty for the financial aspect or loss of human lives.^[24] Thus, it is important to understand the effects of corrosion on the performance of reinforced concrete structures.

Considering its porosity and diffusibility, the quality of concrete mixtures influences the ingress of deleterious substances such as chloride, which compromises the embedded reinforcing steel. Facilities in port areas, particularly pile-supporting wharves, are at risk of chloride attack.^[32] The intrusion of chloride into steel-reinforced concrete is considered the main reason for the durability deterioration of structures in marine environments.^[16] This is the onset of corrosion issues for the concrete member, resulting in the propagation of cracks and degradation of the steel reinforcing strength.^[15] Cracks induced by corrosion provide pathways for the ingress of chloride ions, moisture, and oxygen through the concrete cover.^[14] The intrusion of aggressive agents, particularly the diffusion of chloride, primarily influences the corrosion of steel reinforcements. When the

accumulated chloride reaches a threshold value of 1.20 kg/m^3 , the alkalinity of concrete is altered by the passive film formed over the steel surface.^[14] Corrosion products in the form of rust cause an expansion of 5 to 10 times its original volume.^[1] It pushes the concrete interface, which leads to the formation of cracks on the concrete surface.^[14] The presence of cracks induced by corrosion accelerates the intrusion of atmospheric carbon dioxide and provides a quick and effective passage for corrosive agents, such as chloride ions, into the reinforced concrete member.^[8]

The entire cracking process of concrete induced by corrosion is of great importance for the performance analysis and service life prediction of reinforced concrete structures.^[14] Cracks induced by corrosion generated in concrete surfaces are known as one of the serviceability limit states of reinforced concrete structures.^[35] This is because reinforced concrete structures deteriorate faster with cracks induced by corrosion and affect their serviceability compared to their safety and strength.^[34] Furthermore, cracks affect their ultimate limit state under heightened corrosion conditions.

Significant crack indices include crack frequency, crack width, crack depth, and crack orientation or geometry. Crack frequency, by definition, is the number of cracks per specific length. The crack width is a function of the crack frequency.^[31] This is the primary indicator of the corrosion risk. The limiting crack width prevented reinforcement corrosion.^[6] With an increase in the chloride diffusion due to the increase in crack width, the crack depth also increases, and the accumulated corrosion in steel likewise increases.^[27] However, Lopez-Calvo *et al.* stated that crack width values are not reliable indicators of the anticipated corrosion of the reinforcement and consequent deterioration.^[19]

Crack geometry is the orientation of cracks that appear on the surface of the concrete. For cracks near the steel reinforcement, these cracks initiated in a transverse position surrounding the circumference of the steel reinforcement. These transverse cracks are known as intersecting cracks, while other crack orientations, which are longitudinal cracks, are known as coincident cracks.^[8] Longitudinal cracks suggest the critical development of corrosion in steel reinforcements. These longitudinal cracks are more dangerous because a larger surface area of the steel reinforcement is exposed.

The concrete cover thickness significantly influences the crack indices.^[28] It plays an

essential role in the protection of the reinforcing steel of the concrete structure by significantly increasing its resistance against deterioration due to chloride attack.^[2,9] Houston et al. stated that the protection of concrete structures against corrosion is directly related to the depth of the cover over the reinforcement.^[13] In most design codes, an adequate concrete cover is recommended. A concrete cover of approximately 50 mm is considered acceptable even under service loads considering cracks on the concrete surface. Furthermore, it was observed that a thicker concrete cover resulted in lower crack frequencies. Together with the sound and good quality of concrete, increasing the concrete cover is the most practical means to protect steel reinforcement against corrosion.^[21] However, Lopez-Calvo et al. observed that the concrete cover had no apparent influence on the surface crack widths. Moreover, Pettersson et al. stated that crack widths and concrete cover thickness have insignificant effects on concrete resistivity against corrosion and corrosion rates.

The ratio of "concrete cover to the main reinforcement diameter" (c/d) ratio plays an essential role in the load-carrying capacity of deteriorated concrete columns.^[29] It is a more definitive parameter for protection against corrosion than either the cover or bar diameter.^[26] The c/d ratio is significantly correlated with the rate of corrosion.^[13] Moreover, the relationship between the mass loss, penetration rate, and c/d is linear.^[32] When an increase in c/d was achieved, the rate of corrosion decreased. However, the c/d ratio and bar diameter did not influence the crack width evolution as a function of the steel cross-section loss.

Numerous studies related to the corrosion of steel in concrete can be found in the literature, but very few have tried to determine the influence of crack indices on the corrosion rates of steel reinforcement, such as the critical amount of corrosion required to produce the first crack, the influence of the c/d ratio on crack formation, and corrosion rates of the steel reinforcement. Ratio of concrete cover to steel diameter (c/d) on the crack formation and corrosion rates of steel reinforcement, particularly of wharf facilities that are severely exposed to marine water.

This lack of knowledge is one of the basic reasons why the residual services of corroded-damaged structures have not yet been fully achieved. Therefore, a thorough investigation of the cracking process is necessary, particularly for the critical indices and parameters for the design and assessment of reinforced concrete structures.

This study fills the gaps in the knowledge of the effects of cracks and steel reinforcement corrosion on the durability of reinforced concrete structures. It examined and evaluated the correlations of crack indices, concrete cover, concrete cover ratio, and steel reinforcement diameter with the rates of corrosion. The influence of corrosion rates on the serviceability and deterioration of the corroded damaged structure were determined.

Experimental methods and procedures were performed with this study. Galvanostatic method was used in accelerating corrosion with artificially controlled environment. Data were collected during and after the acceleration of corrosion.

2. MATERIALS AND METHODS

2.1. Research Flow Chart

The following items of work were performed with the design experimental program: Materials and variables characterization, galvanostatic methods of corrosion acceleration methods, and measurement of corrosion indices and research variables. Figure 1 presents an overview of the research methodology.

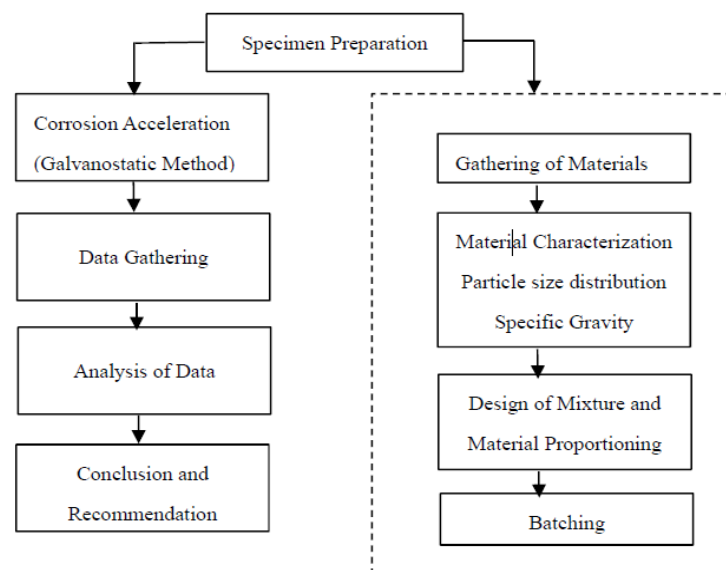

Figure 1: Research flow chart.

2.2. Specimen Preparation. The concrete was designed according to the ACI-211 mix proportion for the Class AA mixture, as shown in Table 1. Table 2 summarizes the materials used in the designed concrete mix. The water- to-cement ratio is 0.45. The ratio of 0.45, based on the maximum permissible water-to-cement ratio for concrete exposed to severe exposure to seawater.^[1]

Table 1: Materials proportion of designed concrete mix.

Cement	Sand	Gravel	Water / Cement ratio
1	1.63	2.12	0.45

Table 2: Materials of Concrete Mixtures.

Material	Kg per m ³ of concrete
Cement	463
Fine Aggregates	754
Coarse Aggregate	982
Water	185

A cube specimen of 300 mm × 300 mm × 300 mm was cast with the specimen description shown in Table 3.

A total of 54–300 mm × 300 mm × 300 mm specimens were cast with the specimen design, as shown in Table 3.

These specimens were singly reinforced longitudinally with a 500 mm-long deformed bar. Three bar diameters (16, 20, and 25 mm) were used with three concrete cover thicknesses (35, 50, and 70 mm).

Table 3: Specimen Design.

Specimen ID	Rebar diameter (mm)	Cover thickness (mm)
I-A	16	35
I-B	16	50
I-C	16	70
II-A	20	35
II-B	20	50
II-C	20	70
III-A	25	35
III-B	25	50
III-C	25	70

After 24 h, the cast specimens were demolded and immersed in potable water for curing for 28 d based on ASTM C192. Fig. 2 shows the details of the specimens, and Fig. 3 shows photographs of the actual specimens.

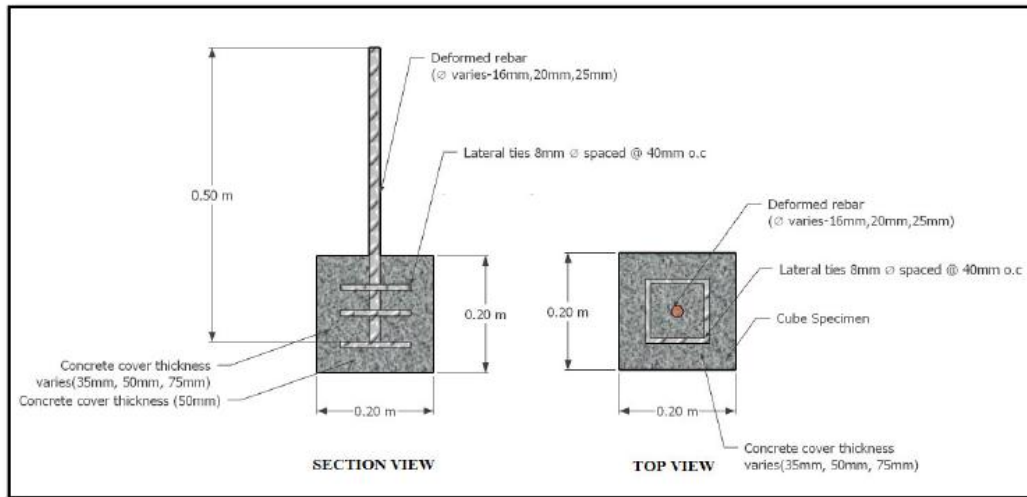

Figure 2a: Detail of Cube Specimen.

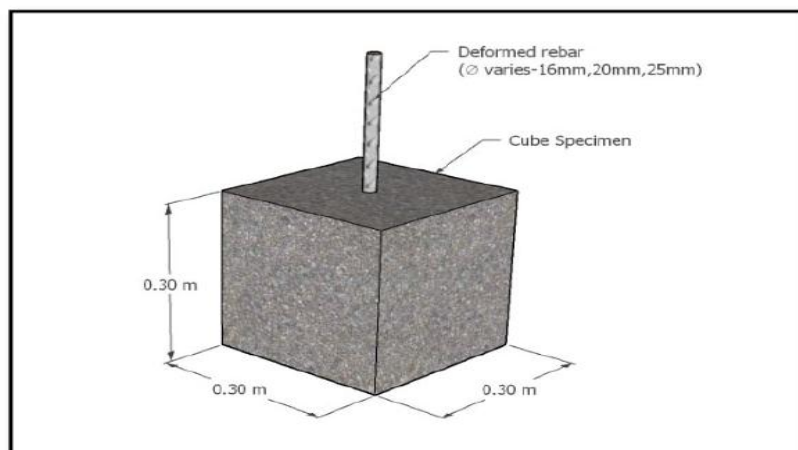

Figure 2b: Scheme of Cube Prism.



Figure 3: Photos of actual specimens.

2.3. Accelerated Corrosion Program The galvanostatic method was used to accelerate the corrosion of the reinforcing steel with a constant current density of 50 Ampere/cm². After 28 days curing period, the sample specimens were partially immersed in a 5% NaCl solution as a simulated environment for a period of 1 year. Every ten days, the specimens were subjected to acceleration for 30 min. During the acceleration procedures, the copper wire was connected to the negative pole, and the other wire was connected to the positive pole of the power supply. Fig. 4 shows a schematic of the galvanostatic method.

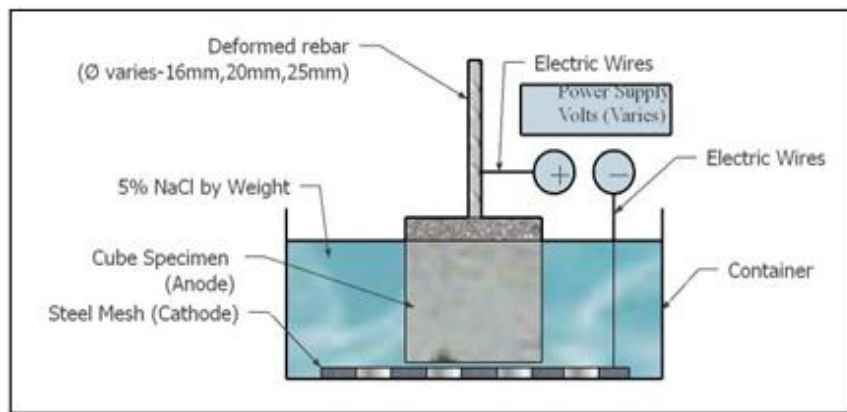

Figure 4: Galvanostatic Method Set-up.

2.4. Data Gathering. Crack development was monitored by measuring the crack widths using a crack ruler with the smallest reading of 0.001 mm. The development of each crack was recorded. The trends of the different surfaces of the specimens were also monitored. Crack patterns were collected over time. The weight of each specimen before and after corrosion acceleration was noted. The reduced diameter was determined from the weight of each corroded baresteel rebar.

Owing to the irregularity of the bar diameter, the actual residual area of the corroded bar and its reduced diameter were estimated by the weight of the rebar after acceleration.

$$\text{Actual area} = W_1 / (L \times \gamma_{\text{iron}}) \quad (1)$$

Where:

W_1 = weight of the reinforcement after corrosion and rust removal (g)

L = is the length of the specimen (mm)

γ_{iron} = 0.00785 g/mm³

The actual mass of rust per unit surface area in accordance with ASTM G1 on rebars

extracted from the concrete specimen after the accelerated corrosion test was computed as follows.

$$Mac = \frac{(W_i - W_f)}{\pi DL} \quad (2)$$

Where:

- Mac = actual mass of rust per unit surface area of the bar (g/cm²)
 Wi = Initial weight of the bar before corrosion (g)
 Wf = Weight after corrosion (g) for a given duration of induced corrosion (t)
 D = Diameter of the rebar (cm)
 L = Length of the rebar sample (cm)

Rate of corrosion was determined using corrosion current density, i_{corr} .

$$i_{corr} = \frac{MacF}{EWt} \quad (3)$$

Where

- i_{corr} = corrosion current density (μAmp/cm²)
 Mac = actual mass of rust per unit surface area of the bar (g/cm²)
 F = Faraday's constant (96487 Amp-sec)
 EW = Equivalent weight of element (27.925 for steel)
 t = time of accelerating corrosion (sec)

Corrosion rates was also determined in terms of Penetration rate, designated as PR.

$$PR = K_1 (i_{cor}/\rho) EW \quad (4)$$

Where:

- PR = Penetration rate (mm/year)
 i_{corr} = corrosion current density (μAmp/cm²)
 K1 = 3.27x10⁻³ mm g/μA cm.yr
 ρ = 7.85 g/cm³ for steel (density)
 EW = equivalent weight of element (27.93 for steel)

Mass loss rate was also determined using the formula.

$$MR = K_2 i_{corr} EWg/m^2d \quad (5)$$

Where:

MR	=	Mass loss rate ($\text{g}/\text{m}^2\text{d}$)
i_{corr}	=	corrosion current density ($\mu\text{Amp}/\text{cm}^2$)
K2	=	$8.954 \times 10^{-3} \text{ g}\cdot\text{cm}^2/\mu\text{A m}^2 \text{ d}$
EW	=	Equivalent weight of element (27.925 for steel)

From the penetration rate formula, designated as PR, the equivalent real time in years and days was determined based on the accelerated time in minutes.^[27]

$$\text{Accelerated real-time (years)} = \text{loss in diameter}/\text{PR} \quad (6)$$

Degree of corrosion, designated as C_{deg} was calculated as.

$$C_{\text{deg}} = (W_i - W_f)/W_i \times 100 \quad (7)$$

Where: W_i = is the weight of the bar before Corrosion (g)

W_f = is the weight of the bar after Corrosion (g)

2.5. Time required to produce the first crack. The empirical equations suggested by Makhoulf and Malhas were used to predict the time to cracking. It was assumed that cracking of concrete would first occur when there is a certain quantity of corrosion products formed on the reinforcement.

The time for cracking to occur and the critical mass of the corrosion products were calculated using the following formulas.

$$T_{\text{cr}} = Q_{\text{cr}} / i_{\text{corr}} \quad (8)$$

$$Q_{\text{cr}} = 0.602 d(1+2c/d)^{0.85} (10^{-4} \text{g}/\text{cm}^2) \quad (9)$$

Where:

T_{cr}	=	Time for cracking (days)
Q_{cr}	=	critical mass of corrosion products ($10^{-4} \text{g}/\text{cm}^2$)
c	=	concrete cover (mm)
d	=	diameter of reinforcing steel bars (mm)
i_{corr}	=	corrosion current density ($\mu\text{Amp}/\text{cm}^2$)

The critical mass of the corrosion product Q_{cr} is the amount of corrosion when concrete cracks.

3. RESULTS AND DISCUSSION

The following section discusses the correlation of each crack index with the different variables used in the experiments.

3.1. Crack Frequency. The concrete cover thickness affects the durability of reinforced concrete structures.^[6] It typically protects the embedded reinforcement against corrosion owing to the high alkalinity of concrete.^[29] The high pH value of concrete acts as a barrier to the ingress of aggressive elements such as chloride in a marine environment.^[17] However, the intrusion of deteriorating chemicals, such as chloride, to the reinforcing concrete causes corrosion of the steel rebar. Corrosion products in the form of rust cause expansion at the interface between the concrete and steel rebar. It expands by approximately three (3) to five (5) times its original volume. Owing to the volume expansion of the steel rebar, the concrete interface was pushed, and cracks eventually formed on its surface.

Several crack indices induced by corrosion affect several corrosion parameters and variables. The crack frequency is a crack index induced by corrosion caused by chloride attack. The crack frequency is the number of cracks that appear on the specified surface of a specimen.^[6] Crack frequency is a fundamental factor that influences the amount of corrosion.^[4] The generation of multiple cracks indicates more pathways for the deteriorating agents to penetrate the concrete surface. This pathway allows the entry of water, oxygen, and chlorides, which accelerates the decomposition of the steel rebars into its original state, which is rust.

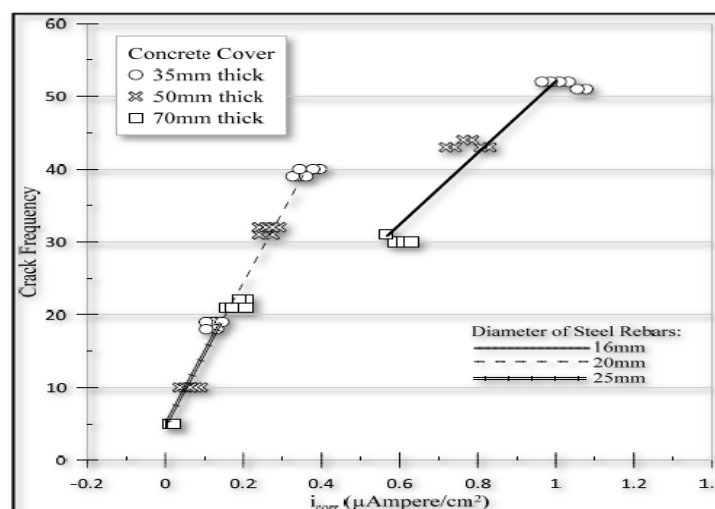

Figure 5: Correlation of Crack Frequency and Corrosion Rates.

As shown in Fig. 5, a thicker concrete cover (70 mm thick) had the least number of cracks, whereas a thinner cover (35 mm thick) had a higher number of cracks in each group of specimens. A more significant number of cracks appeared as the concrete cover became thinner, while more profound covers implied fewer cracks. The crack frequency is inversely related to the concrete cover thickness. The 35 mm concrete cover thickness has 18-52 crack frequency, 50 mm concrete cover has 10-44 crack frequency, and 70 mm concrete cover thickness has 5-31 crack frequency. The crack frequency increased by approximately 30% when the concrete cover thickness decreased from 70 mm to 50 mm. From the above figure, it was verified that a thicker concrete cover provides more profound protection for the embedded steel reinforcement. The concrete cover should then be increased to reduce the number of crack frequencies. Thus, according to Lopez-Calvo *et al.*, the effectiveness of concrete protection depends greatly on the concrete thickness, and a thickness of 25 mm and 45 mm provides significant protection to the embedded steel.^[19]

The sizes of the deformed steel reinforcements also influenced the deterioration rates of the reinforced concrete structures. As shown in Fig. 5, the group of specimens with a smaller reinforcement diameter (16 mm Ø) had the highest crack frequency compared to specimens with a larger diameter (25 mm Ø) reinforcing steel bars.

The 16 mm-diameter deformed steel reinforcement has a lower resistance to corrosion. A higher corrosion rate immediately leads to the formation of corrosion or rust on the steel itself. Rust products cause de-bonding between the interface of the steel and concrete and allow cracks to be generated on the surface of the concrete. The group of specimens with 16 mm diameter reinforcement had a minimum 30- crack frequency and a maximum 50- crack frequency. A 30-cracks frequency corresponds to a $0.63 \mu\text{A}/\text{cm}^2$ corrosion rates (i_{corr}), while 50 the crack frequency has a $1.08 \mu\text{A}/\text{cm}^2$ corrosion rates (i_{corr}). Steel reinforcement with a diameter of 20 mm has an in-between lower resistance to corrosion. A group of specimens with 20 mm diameter steel deformed rebars obtained a minimum 20- crack frequency and a maximum of 40 crack frequencies. It has corrosion rates (i_{corr}) in the range of $0.21\text{-}0.40 \mu\text{A}/\text{cm}^2$). The 25 mm-diameter reinforcement rebar has a higher resistance to corrosion. The specimens had a minimum 5- crack frequency and a maximum 20- crack frequency. It has corrosion rates (i_{corr}) in the range of $0.023\text{-} 0.13 \mu\text{A}/\text{cm}^2$. The crack frequency of the specimen with 16 mm Ø doubled the crack

frequency of the specimen with 25 mm \emptyset rebars. The corrosion rates of the 16 mm-rebars tripled increased with the 20 mm reinforcement, and increased eight times with 25 mm reinforcement diameter bars.

As verified from the experiments, in general, specimens with higher crack frequencies have higher rates of corrosion, i_{corr} ($\mu\text{A}/\text{cm}^2$), whereas specimens with lower crack frequencies have lower corrosion rates. The corrosion rates of the samples with multiple cracks were higher than those of the specimens with fewer cracks. Higher corrosion rates of steel reinforcement cause the concrete surface of the specimen to crack with multiple numbers, which in turn leads to a high risk of deterioration. According to Arya and Darko, decreasing the corrosion rate reduces the crack frequency on the concrete surface.^[6]

Furthermore, the deterioration of reinforcement rebars is significantly related to the crack frequencies and concrete cover thickness, which should be used as a basis for considering its serviceability. This study verified that having the highest crack frequency provides several pathways for the deteriorating agents to penetrate and depassivate the embedded steel rebars. A thicker concrete cover provided significant protection by reducing the crack frequencies on the concrete surface.

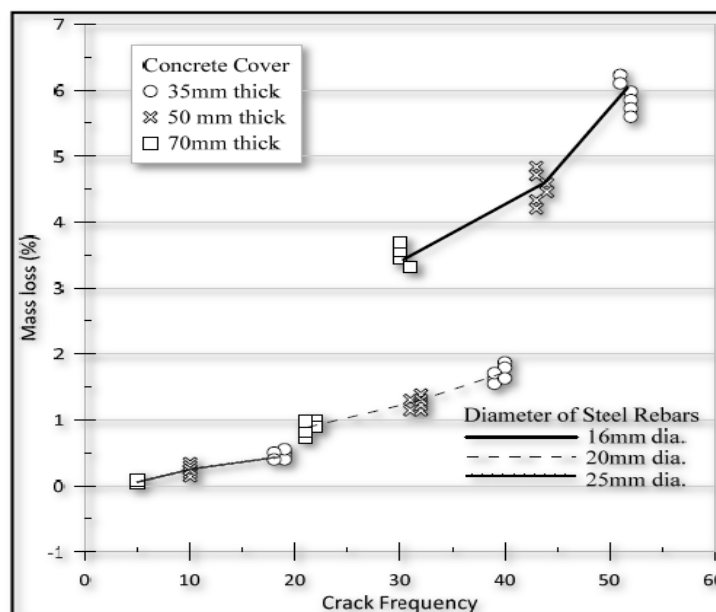

Figure 6: Correlation of Crack Frequency and Mass Loss (%).

From Fig. 6, the percent mass loss is higher for the group of specimens with 16 mm \emptyset reinforcement and lower for the group with 25 mm \emptyset reinforcement. The group of

specimens with a higher crack frequency exhibited a higher percentage of weight reduction. A higher crack frequency allows a more definitive passage of deteriorating agents to the surface of the concrete and leads to the imminent deterioration of steel rebars.

A specimen with a smaller reinforcement diameter (16 mm \emptyset) suffered a significant reduction in its mass because it has a higher crack frequency that has formed on the surface of concrete. It has a crack frequency in the range of 30-50, and it has a percent mass reduction of 3.70-6.23. The specimen with 20 mm \emptyset deformed bars has a crack frequency of 20-40, and it has a percent mass loss of 0.98-1.87. The specimen with 25 mm \emptyset deformed bars had a crack frequency in the range of 5-20, with a percent mass loss of 0.09-0.50.

Doubling the crack frequency formed on the concrete surface doubled the reduction in its mass. The percent reduction in rebar weight was significantly influenced by the crack frequencies formed on the concrete surface. A significant number of crack frequencies led to a higher percentage of mass loss in the steel reinforcement bars. The results affirms with Giordano, L., et al., that corrosion is significantly influenced by crack frequency rather than by their crack width or its opening value.^[12] This is because a number of cracks indicate more pathways for the deteriorating agents to penetrate and destroy the state of the reinforcement rebars, which affects the concrete surrounding the concrete. Thus, the crack frequency significantly influenced the rate of deterioration of the structures.

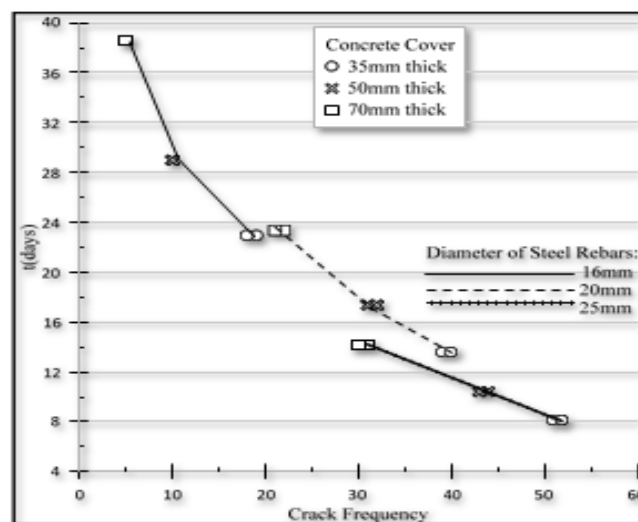

Figure 7: Influence of Crack Frequency to Time of Cracking of Concrete Specimen (days).

In Fig. 7, a concrete specimen with a smaller diameter (16 mm) takes a shorter number of days of accelerating procedures for the formation or creation of cracks on the concrete surface, while larger reinforcement diameters (20 mm and 25 mm) took a longer period of accelerating corrosion before cracks formed on the surface of the concrete. For the group of specimens with 16 mm \varnothing rebars, within a period of 8 days of corrosion acceleration, cracks immediately appeared on the surface of the specimen with a thinner concrete cover (35 mm). With the same diameter (16 mm) and with a thicker concrete cover (70 mm), it took 15 days to accelerate corrosion before cracks were observed on the concrete surface. For a group of specimens with 20 mm \varnothing steel reinforcement, a 14 days period of accelerated corrosion before cracks appeared on the surface of concrete with a thinner cover of 35 mm. It takes 24- days to accelerate corrosion before cracks form with a 70 mm concrete cover. For the 25 mm \varnothing steel reinforcement, it takes 23 days period of corrosion acceleration before cracks form with a 35 mm concrete cover. With a thinner concrete cover (70 mm), a corrosion acceleration of 39 days is required for the cracks to form on the concrete surface.

Furthermore, as verified in Fig. 7, the diameter of the steel reinforcement and concrete cover thickness influence the generation of cracks during the day period of the corrosion acceleration procedures or techniques. Cracks provide a passage for the deteriorating agents to penetrate the surface of concrete; once it reaches the reinforcement steel, it destroys the passivation between steel and concrete, eventually leading to the formation of a rust and corrosion. In turn, the corrosion products cause cracking on the surface of the reinforced concrete specimen.

As revealed from the experiments, the crack frequency allows faster and easier penetration of deteriorating agents to the surface of concrete. Furthermore, the diameter of the steel reinforcement influenced the probability of deterioration of the concrete specimen. A smaller reinforcement diameter has a higher rate of corrosion; it takes a shorter period of accelerating corrosion for the formation of cracks on the concrete surface. A larger reinforcement diameter has a lower corrosion rate, and it takes a longer period of accelerating corrosion before cracks form on the surface of the concrete specimens.

3.2. Crack Width. Crack width is one of the most practical indices for the design and assessment of reinforced concrete structures.^[17] It is an essential index used to determine the durability of reinforced concrete structures.^[34] It is desirable to predict the growth of

the crack width over time so that a better informed decision can be made concerning the repairs due to concrete cracking. In addition, accurate prediction of crack width can allow timely maintenance, which prolongs the service life of reinforced concrete structures.^[34]

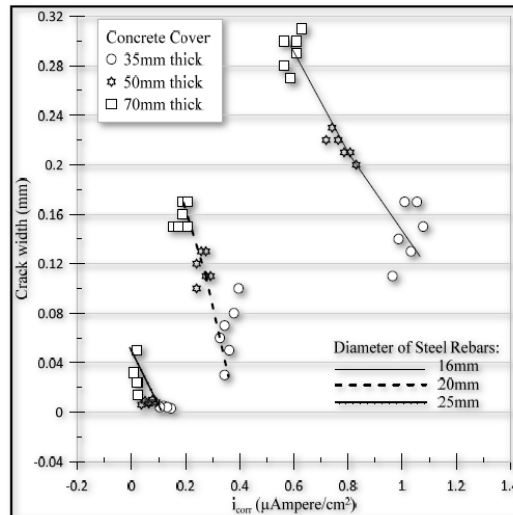

Figure 8: Correlation of corrosion rate and crack widths.

Concrete cover, which typically protects the embedded steel, influences the width of the cracks generated on the surface of the concrete. As shown in Fig. 8, a thicker concrete cover (70 mm) has a wider crack opening compared with thinner concrete covers (35 mm and 50 mm), which has a smaller crack opening. An increase in the concrete cover thickness eventually increases the maximum crack width. The crack width decreased when the concrete cover was reduced. The width of the crack opening is linearly related to the concrete cover thickness. As the concrete cover increased, the crack width also increased, and the analysis was the same for all sizes of steel reinforcement diameters. The thicker concrete cover had a wider crack because it had a slightly longer period (time) to travel and penetrate the concrete surface before reaching the embedded steel; as the cracks propagated, their width also widened in a V-shaped form, pointing outward from the position of the steel reinforcements. According to the study by Jin et al., a thicker concrete cover can retard the initial cracking but will promote the propagation speed of corrosion cracks.^[14]

According to Makhoulf & Malhas, the use of a 50 mm concrete cover leads to acceptable levels of crack widths even under service loads.^[21]

Smaller reinforcement diameters have higher corrosion rates, whereas larger-diameter reinforcements have lower corrosion rates. A specimen with a smaller reinforcement diameter (16 mm Ø) accumulated a crack with wider openings and was in great range compared to other specimens with larger reinforcement diameters (20 mm Ø and 25 mm Ø). The group of specimens with 16 mm Ø reinforcement had a range of crack widths of 0.11 mm-0.31 mm, it has corrosion rates in the range of 0.63-1.07 $\mu\text{Amp/sec}$. Specimens with 20 mm Ø reinforcement have a range of crack widths of 0.016 mm-0.17 mm and corrosion rates in the range of 0.15-0.40 $\mu\text{Amp/sec}$. Specimens with 25 mm Ø reinforcement have a range of crack widths of 0.003 to 0.05 mm, and they have corrosion rates in the range of 0.02- $\mu\text{Amp/sec}$. As shown in Fig. 9, as the corrosion rates increased, the crack widths increased, and it doubled its value or opening.

Furthermore, in each group of different diameter sizes, the initial crack widths observed were large; however, with further increase in corrosion rates and even a reduction in concrete cover thickness, crack openings were stuck or remained at the observed value of smaller openings compared to the initially observed wider value of openings. From the gathered data, the specimen with 16 mm Ø, the observed maximum crack width was 0.31 mm with 0.63 $\mu\text{Amp/sec}$. However, the minimum crack width (0.11 mm) has a high corrosion rate of 0.96 $\mu\text{Amp/sec}$. Similar to the 20 mm and 25 mm Ø reinforcements, the initial recorded specimen had wider crack openings with lower corrosion rates. The corrosion rates of specimens with the same diameter reinforcement are not constant; thus, several cracks have different crack widths or openings that have formed. The verified results suggest that the corrosion rates do not predict the width of cracks that will form; it is the resistance of different reinforcement diameters used, which will provide a significant correlation with the crack width or opening size. Thus, the corrosion rates were not correlated with the widths of the cracks induced by the corrosion acceleration. However, contradicting the results reported by Lin *et al.*, the surface crack width is closely correlated with the corrosion level.^[18]

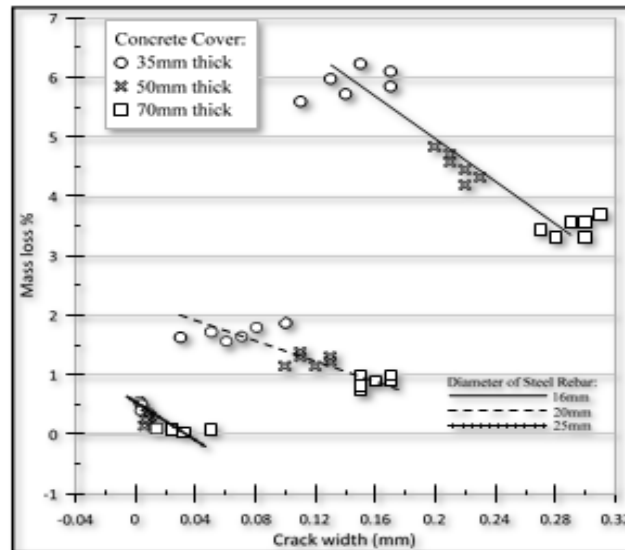

Figure 9: Effect of Crack Width on Percent Mass Loss.

It was verified from Fig. 9 that a group of specimens with 16 mm \emptyset reinforcement had the highest reduction in its mass, compared with other groups of different reinforcement diameters (20 mm \emptyset and 25 mm \emptyset). Likewise, data obtained with 16 mm \emptyset were more scattered compared to the other groups. For 16 mm \emptyset steel rebars, the loss in mass is 3.70%; for 20 mm \emptyset , the loss is mass of 0.98%, and for 25 mm \emptyset , the mass loss is 0.08% with a 0.05 mm crack width. Steel rebars with smaller diameters have a lower resistance to corrosion; thus, it suffered a huge reduction in its mass as it turned into rust during its disintegration. Wider crack opening leads to continuous and faster disintegration of the steel reinforcement until its mass reduces significantly. In addition, as shown in Fig. 9, the thickness of the concrete cover influences the generation of crack width and the reduction of its mass. A thicker concrete cover acquired wider crack openings, but it had a lower percentage of mass reduction. The results were consistent with those of the other two groups with reinforcements of different diameters.

During the initial period of accelerating corrosion, the higher reduction in the mass of the steel rebar corresponded to the wider crack openings of the concrete specimen; however, with further increase in crack widths, the percent mass reduction of steel rebars was observed to decrease. In the initial period, a significant loss in mass was observed; however, during the propagation period, the width of the cracks further increased, but the mass loss reduction decreased. For the 16 mm \emptyset steel rebars, a 0.31 mm crack width has a mass loss of 3.70%, while a 0.11 mm crack width has 5.60% mass loss; for 20 mm \emptyset , a 0.17 mm crack width has a mass loss of 0.98%, while a 0.03 mm crack width has a mass

loss of 1.63%; and for 25 mm Ø, a 0.05 mm crack width has a mass loss of 0.08% , while a 0.003mm crack width has a mass loss of 0.55%.

The results reveal that the crack width significantly affects the loss of its percent mass owing to the corrosion of steel rebars only at the initial crack propagation. The lower reduction in the percent mass loss with wider crack widths suggests that the crack width has no significant correlation with the reduction in its mass during the propagation period. Based on the study by Bhaskar et al. al., great increase of weight loss of steel is on 0.20 mm crack width compared to 0.20 mm-0.40 mm crack widths, which implies that crack itself influences corrosion more than the crack width itself.^[7] This indicates a nonlinear relationship between the crack width and the degree of corrosion. Thus, the crack width does not influence the reduction in its percent mass on the remaining service life of the specimen. If the crack width opening is narrower or broader, it can still cause a greater reduction in its mass during its service life. However, the crack width significantly influences the bond reduction of steel and concrete, which leads to an immediate spalling of the concrete cover. The deterioration of concrete with wider cracks due to corrosion similarly illustrates the collapse of the structures with no reinforcement.

3.3. Crack Depths. In general, the rate of corrosion of a smaller reinforcement diameter is higher than that of larger- diameter steel reinforcements. The smaller diameter of the steel reinforcement (16 mm) was less resistant to deterioration. As corrosion acceleration is successful in promoting rust in steel, cracking occurs on the surface of the concrete cover. Pathways established through crack opening for deteriorating agents penetrate the concrete surface. Cracks on the concrete surface allow the deteriorating agents to penetrate the concrete surface. The depth of the passage formed was the depth of the cracks. The depths of the cracks formed on the concrete surface were linearly related to the amount of diameter loss of the steel reinforcement.

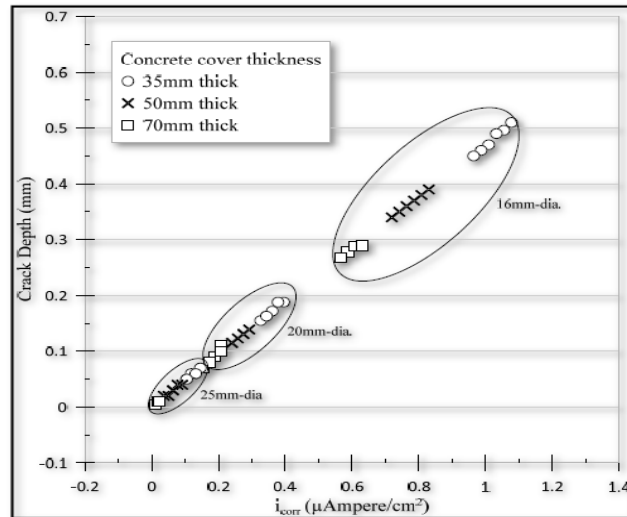

Figure 10: Correlation of Crack Depth with Corrosion Rates.

The corrosion rates significantly predicted the depths of the cracks that formed on the concrete cover. Specimen with 16 mm Ø has a lower corrosion rate and produces crack depths in the range of 0.28 mm-0.51 mm; 20 mm Ø has an average corrosion rate that produces crack depths in the range of 0.07 mm-0.19 mm; and 25 mm Ø has a lower corrosion rate and produces crack depths in the range of 0.004 mm-0.07 mm. The corrosion rates exhibited a linear correlation with the crack depth. The depth of passage for pathways of deteriorating agents increased by almost 60% with an increase in the corrosion rate.

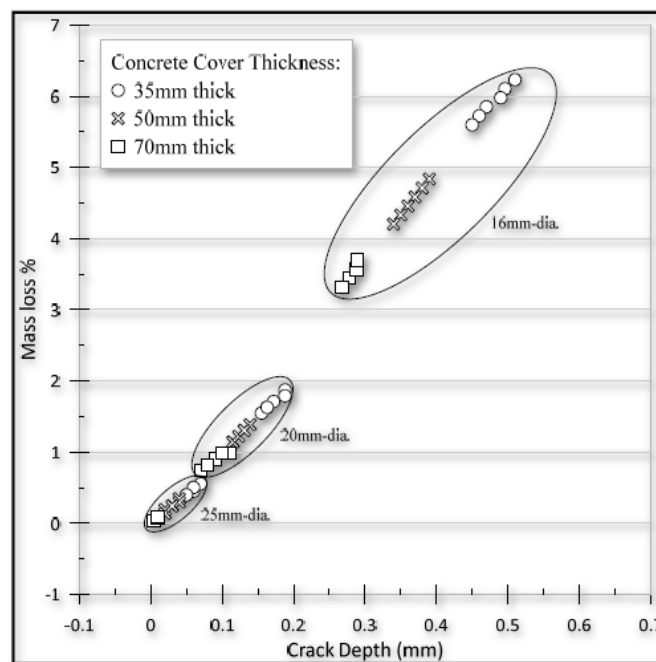

Figure 11: Correlation of Crack Depth & Percent Mass Loss.

As shown in Fig. 11, the mass loss of the steel reinforcement increased with an increase in the crack depth. The crack depth has a linear correlation with the percent reduction in the mass loss. The deeper the crack, the deeper the deteriorating agents can penetrate the specimen, and the greater the percentage of mass loss the rebar specimen obtained. The specimen with a maximum crack depth of 0.51 mm has a mass loss of 6.23%; the specimen with a minimum crack depth of 0.27 mm has a mass loss of 3.32%. The results show that the percentage loss of mass of rebar specimens is highly correlated with the depth of cracks.

The group of specimens with a smaller reinforcement diameter (16 mm) had a large range of crack widths and the highest percentage of steel weight reduction. 16 mm Ø suffered a great reduction of its mass and a depth of cracks on the concrete surface with range of 0.28 mm-0.51 mm.; 20 mm Ø has a cracks depth with range of 0.07 mm-0.19 mm; and 25 mm Ø has a crack depth with range of 0.004 mm-0.07 mm. The specimens had different ranges of cracks owing to the concrete cover thickness (35 mm, 50 mm, and 70 mm). It was verified that thinner concrete covers allowed the cracks to penetrate faster and obtained the highest percentage reduction in its mass. Thus, a significant crack depth indicates a significant reduction in the steel reinforcement weight and a significant deterioration in the structures.

3.4. Crack Geometry. With successful acceleration procedures through the galvanic corrosion acceleration technique, cracks form initially at the outer surface of the concrete circumscribing the steel rebars. Cracks induced by corrosion that immediately appear surrounding the steel rebar are known as intersecting cracks. The intersecting cracks propagated outward. With further propagation, as it reached the other side of the cube specimen, coincident cracks succeeded in the process, as illustrated in Fig. 12.

Cracks induced by corrosion formed in the surrounding circumference of the exposed steel rebar, but this typically occurs in another way. Owing to the harsh environmental elements, hairline cracks formed and propagated on the concrete surface and penetrated the embedded steel reinforcements. The hairline cracks penetrated the concrete surface in the transverse direction. As it reached the steel rebar, the pH value decreased, and the passivation between the concrete and steel rebars was destroyed. Rust will form, and because rust products are more than three times the original volume of the steel, it will push the concrete at its nearly face, and eventual cracks will continue to grow at the

circumference of the steel surrounding concrete inside the covering concrete. The intersecting cracks propagated in an outward direction toward the outer concrete surface. As it reaches the outer surface, it propagates longitudinally.

Intersecting cracks are also known as transverse cracks, whereas coincident cracks are known as longitudinal cracks. Longitudinal cracks are more critical for deterioration than transverse cracks because they expose a more profound surface area to the steel rebar. Intersecting cracks can shorten the initiation period because they provide pathways for the deteriorating agents to penetrate the steel rebar. Longitudinal cracks shorten the designed service life of the structures because they can lead to concrete spalling when the width of the cracks increases further. Longitudinal cracks are more likely to appear with higher corrosion rates than transverse cracks.^[22] As verified in this study, intersecting cracks appeared significantly owing to the higher corrosion rates. Longitudinal cracks are evidence of the critical development of corrosion in reinforcing steel rebars of reinforced concrete structures.

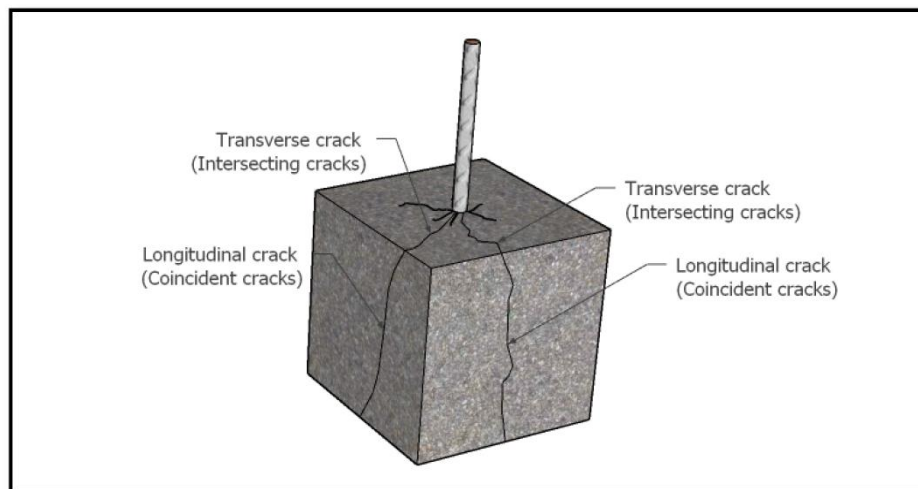

Figure 12: Crack Initiation & Propagation.

3.5. Ratio of concrete cover to steel bar diameter (c/d). (c/d) is a useful guide for estimating the corrosion resistance of steel in concrete.^[25] As shown in Fig. 13, as the ratio of the concrete cover (c/d) decreased, the corrosion rate increased. The value of c/d decreases with a reduction in the concrete cover thickness for all steel reinforcement diameters. A thinner concrete cover has a higher corrosion rate than a thicker concrete cover. A thicker concrete cover provides significant protection against corrosion because of its higher corrosion resistance.

Furthermore, with the same concrete cover, a smaller reinforcement diameter (16 mm) had the highest c/d ratio and the highest corrosion rate. Increasing the concrete cover decreased the c/d and corrosion rates. Based on the study by Houston *et al.*, greater corrosion protection was provided with high c/d values, and good protection was provided by c/d values greater than 3.0.^[13] According to Ravindrarajah and Ong, a larger diameter bar with reduced cover thickness produced a higher degree of corrosion in comparison with smaller diameter bars with larger cover.^[25]

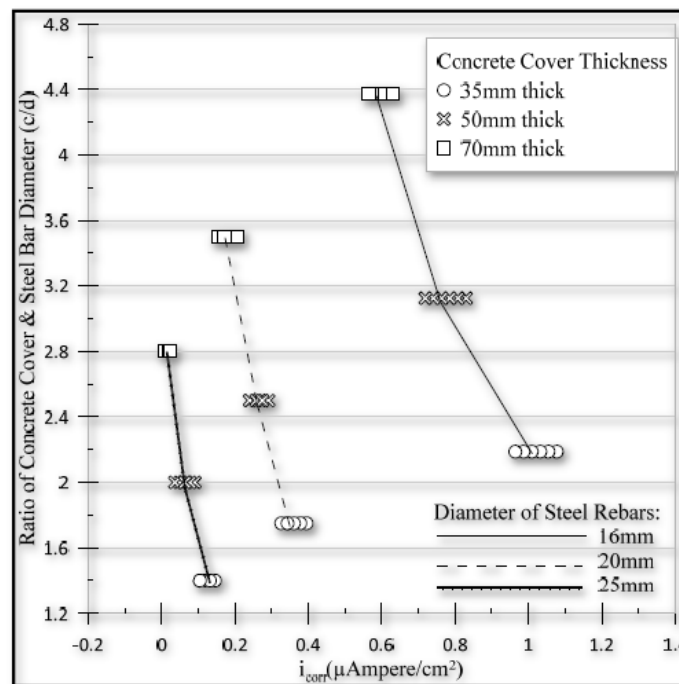

Figure 13. Effects of c/d to the rate of corrosion of steel rebar.

3.6. Time required to produce the first crack. Predicting the time of cracking induced by corrosion is an essential factor used in the prediction of the serviceability life of corroded reinforced concrete structures, particularly pier portfacilities, which are severely exposed to aggressive marine elements. The time of corrosion initiation and corrosion rates are the two factors that influence the deterioration of structures exposed to an aggressive marine environment. The two deterioration factors are also related to the residual capacity of the corroded structures.

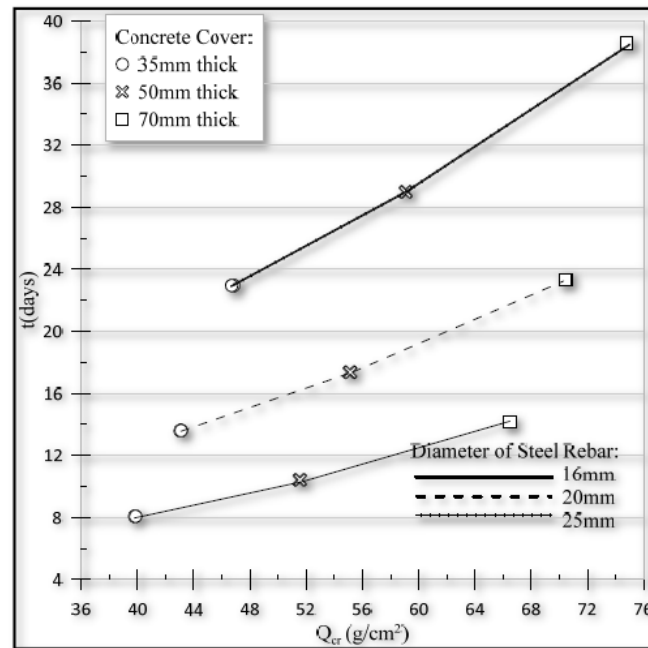

Figure 14: Influence of amount of corrosion to time of cracking.

A critical amount of corrosion Q_{cr} is the weight per square unit of rust that has formed from the decomposition of the steel rebars due to the deteriorating agent, and it causes the formation of initial cracks on the surface of the concrete, which embeds the steel reinforcement. It is the amount of corrosion products that add up to the original volume of the steel and cause expansions on its concrete surfaces. The critical amount of corrosion, Q_{cr} , significantly affected the cracking time of the specimen. An increase in the amount of corrosion that accumulates in a certain period causes cracking and eventually spalling of the concrete cover.

The concrete cover thickness also affected the generation of cracks on the concrete surface. This shows that the cracking time of the reinforcement concrete is linearly correlated with its cover thickness. A thinner cover will cause immediate cracking of the concrete surface and a thicker surface pending the years (days) for cracks to appear on the surface of the concrete reinforcement. The specimen with the highest corrosion rates produced a *large quantity of rust products* in a short period of time and immediately cracked its surface.

According to Chun-Qing *et al.*, the corrosion current density is the most important single factor that affects both the cracking time and the growth of crack width.^[10] For the group of specimens with the lowest corrosion rates, it takes a longer time for cracks to appear on

the surface of the concrete specimen. A 16 mm \varnothing reinforcement with a 35 mm concrete cover thickness has a critical amount of 39.82 g/cm², which causes crack formation within an 8-days period only. It requires 66.49 g/cm² of corrosion for the generation of cracks on the surfaces of concrete specimens for approximately 14-days days, but with a 70 mm-thick concrete cover. For a 20 mm \varnothing with a 35 mm-thick concrete cover, it requires a 14-days to promote a critical value of 43.05 g/cm² before the appearance of the cracks. A maximum of 24-days with a 70 mm-thick concrete cover to generate a critical value of 70.44 g/cm² to promote crackson the entire surface of the concrete specimen. For a 25 mm \varnothing with 35 mm-thick cover thickness, it requires days to produce 46.84 g/cm² amount of corrosion products, and a 39-days of acceleration with a 70 mm-thick cover thickness to produce 74.77 g/cm² critical amount of corrosion to generate cracks on all of its surfaces. It was verified that the corrosion rates influence the generation of critical amounts of corrosion and the initial cracking time of the reinforcedconcrete specimens.

3.7. Corrosion level to produce the first crack. The amount of corrosion is a crucial factor that can be used to predict the residual safety and serviceability of reinforced concrete structures. The key factor in the life of concrete structures is the amount of steel corrosion when the concrete covers cracks.^[35] Concrete cracking is usually identified as a serviceability limit state, and the critical amount of corrosion products is important in the assessment of the serviceability of corroded reinforcement steel rebars.

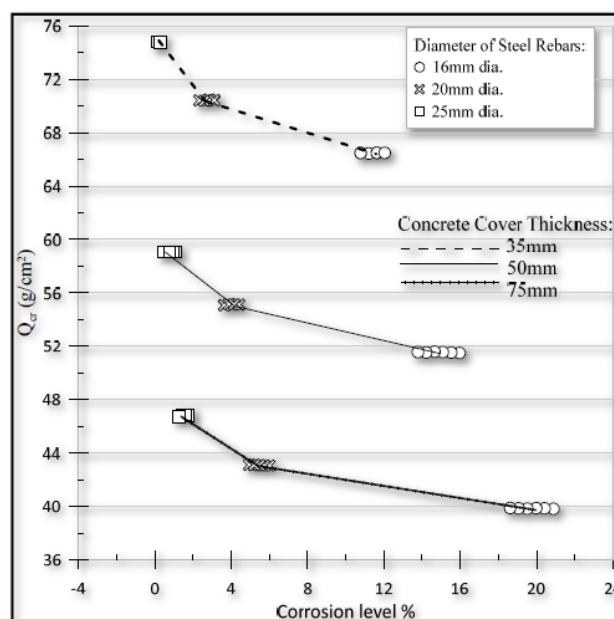

Figure 15: Corrosion level vs. critical amount of corrosion.

As shown in Fig. 15, the concrete cover thickness affects the percentage of corrosion. The thinner concrete cover (35 mm) had the highest percentage of corrosion level compared with the thicker concrete covers (50 and 70 mm). It also influences the critical amount of corrosion, and a thicker concrete cover has the highest amount of critical corrosion. The smaller reinforcement diameter (16 mm Ø) had the highest corrosion level but had a smaller critical amount of corrosion compared with the 20 mm and 25 mm steel reinforcement diameters.

From the results, a growth of approximately 39.82 g/cm² to 46.84 g/cm² of corrosion products in a group with 35 mm cover thickness led to the development of cracks on the concrete surface. It induces a visible crack of 0.004 mm width with a corrosion level of 1.26%. In a group of 50 mm-cover thickness, a critical value of 51.50 g/cm² to 55.14 g/cm², it induces a visible crack of 0.006 mm with a 0.44% corrosion level. For a cover thickness of 70 mm, a critical value of 66.44 g/cm² to 74.79 g/cm² induces a visible crack of 0.014 mm with a corrosion level of 0.27%.

A growth of 0.10 to 0.20 mm thick corrosion products was sufficient to develop cracks on the surface of the concrete.^[25] A rebar cross-section reduction of only a few micrometers is required to induce cover cracks (0.10 mm width) under the conditions of the specimens.^[5] A radius loss of approximately 15-50µm µm generate the first visible crack of greater than 0.10 mm width.^[4]

3.8. Effects of crack indices on the residual life of reinforced concrete exposed to an aggressive marine environment Crack indices induced by corrosion have a significant influence on the durability of corroded reinforced concrete structures. Durability parameters include concrete cover, material durability properties, amount of reinforcement, and dimensions of the structures. A thicker concrete cover tends to decrease the crack frequency, but increasing the concrete cover leads to an increase in the width of the cracks that have formed. Thus, it has been recommended that increasing the concrete cover requires more reinforcement to limit the surface crack width to its allowable value.

Crack indices induced by corrosion have a direct relationship with the residual life of corroded reinforced concrete structures as a whole. Structures deteriorate and reduce their serviceability and residual life with the generation of cracks on the concrete surface.

Cracks are significant indicators of the serviceability of structures. Structures in marine environments deteriorate in terms of failure or collapse due to cracks. Thus, the appearance of cracks is the primary basis for the repair and maintenance of structures to prolong their service life and maintain their structural performance and durability.

It has been confirmed that a comparatively short period of time elapsed between the steel disintegration and the occurrence and appearance of cracks in the concrete surface. The growth of crack width followed a linear trend with corrosion attack and its propagation until levels of approximately 200-300 μm . It was further observed that the prediction of the evolution of the crack is more difficult because its geometry is also a crucial factor. The spalling of the concrete cover requires a longer process and is related to crack generation.

4. CONCLUSIONS. Crack indices including crack frequency, crack width, crack depth, and crack geometry, generally have a linear relationship with the rate of corrosion. It also has a direct correlation with the rate of deterioration and residual life of reinforced concrete structures exposed to an aggressive marine environment. Crack indices can help assess the serviceability and durability of reinforced concrete structures, particularly in coastal areas that are exposed to an aggressive marine environment throughout their life. Thus, the residual life of corroded- damaged structures can be assessed using the crack indices.

The following were the conclusions.

1. Higher corrosion rates produce a significant number of crack frequencies and more deteriorated reinforced concrete materials.
2. Higher corrosion rates resulted in more extensive crack widths compared to lower rates of corrosion. Smaller-diameter reinforcements (16 mm) provide more extensive cracks to the concrete surface than larger-diameter reinforcements (20 mm and 25 mm).
3. The wider the crack, the higher the corrosion rates.
4. Higher corrosion rates resulted in significant crack depths. Smaller-diameter reinforcement (16 mm) provided greater crack depths compared with larger steel reinforcement diameters (20 mm and 25 mm). Thus, the crack depth is directly related to its width. As the width of the cracks increased, the depth increased.
5. Longitudinal cracks are more likely to result in higher corrosion rates than transverse

cracks. Transverse cracks appeared as long as the initial cracks were generated, whereas longitudinal cracks appeared when cracks propagated.

6. The thicker the concrete cover, the lower the crack frequency. A thinner concrete cover generated several cracks on the concrete surface. However, a thicker concrete cover produces wider cracks, whereas a more lightweight concrete cover provides a smaller crack.
7. As the ratio of the concrete cover (c/d) decreased, the corrosion rate increased.
8. The critical amount of corrosion, Q_{cr} , significantly affects the time required for the specimen to generate cracks. An increase in the amount of corrosion that accumulates in a certain period causes cracking and eventually spalling of the concrete cover.
9. When corrosion of reinforcing bars occurs, crack formation in concrete can lead to a more significant reduction in the strength and ductility of the structures than expected. The repair of the structures must be performed when cracks are formed along the reinforcing bars.

5. RECOMMENDATIONS

It is recommended to study the crack indices due to corrosion with concrete reinforced with prestressing wires, its corrosion level, and deterioration rates.

6. CONFLICT OF INTEREST

The authors declare no conflicts of interest.

7. REFERENCES

1. ACI 211.1-91 Standard Practice for Selecting Proportions for Normal Heavyweight, and Mass Concrete, 1999.
2. Al-Galawi, N. M, Al-Tameemi, A. A. H., Al-Jarrah, S.H. (2016). Effect of Age and Concrete Cover Thickness on Steel Reinforcement Corrosion at Splash Zone in Reinforced Concrete Hydraulic Structures. *International Journal of Scientific & Technology Research*, September 2016; 5(09): 2277-8616.
3. Allan, M. (1995). Probability of corrosion-induced cracking in reinforced concrete. *Cement and Concrete Research*, 1995; 25(6): 1179-1190. [https://doi.org/10.1016/0008-8846\(95\)00110-X](https://doi.org/10.1016/0008-8846(95)00110-X)
4. Alonso, C., Andrade, C., Rodriguez, J., & Diez, J. (2006). Factors controlling the cracking of concrete affected by reinforcement corrosion. *Materials and Structures*, 2006; 31(7): 435-441. <https://doi.org/10.1007/BF02480466>.

5. Andrade, C., Alonso, C. And Molina, F.J. (1993). Cover cracking as a function of bar corrosion: part 1- experimental test. *Materials and structures*, 1993; 26(162): 453-464. <https://doi.org/10.1007/BF02472805>.
6. Arya, C., & Ofori-Darko, F. Influence of crack frequency on reinforcement corrosion in concrete. *Cement and Concrete Research*, 1996; 26(3): 345-353. [https://doi.org/10.1016/S0008-8846\(96\)85022-8](https://doi.org/10.1016/S0008-8846(96)85022-8).
7. Bhaskar, S., Gettu, R., Neelamegam, B.M. (2011). Studies on Chloride-Induced Corrosion of Reinforcement Steel in Cracked Concrete. *SDHM*, 2011; 7(4): 231-251.
8. Blagojevic, Andrija, Fennis, Sonja, & Walravel, Joost C. Impacts of cracks on chloride-induced corrosion and durability of reinforced concrete structures- a literature review. The Delft University of Technology, Faculty of Civil Engineering and Geosciences, Delft, the Netherlands.
9. Cabrera, J.G. (1996). Deterioration of concrete due to reinforcement steel corrosion.” *Cement and Concrete Composites*, 1996; 18(1): 47-59. [https://doi.org/10.1016/0958-9465\(95\)00043-7](https://doi.org/10.1016/0958-9465(95)00043-7).
10. Chun-Qing, Li, R.E. Melchers, J.-j. Zheng. (2007). Analytical model for corrosion – induced crack width in reinforced concrete structures.” *ACI Struct. J.*, 103: 479-487.
11. Deng, T., Chanakya, Arya. (2017). Towards the design of a specimen to investigate corrosion in cracked concrete members.” UCL Department of Civil, Environmental and Geomatic Engineering, Gower ST. London, WCIE 6BT. <https://doi.org/10.2991/icmmct-17.2017.239>.
12. Giordano, L., Mancini, G., and Tondolo, F. (2011). Reinforced Concrete Members Subjected to Cyclic Tension and Corrosion. *Journal of Advanced Concrete Technology*, 9(3): 277-285, October 2011 / Copyright @ 2011 Japan Concrete Institute. (2011). <https://doi.org/10.3151/jact.9.277>.
13. Houston, James T., Atimtay, Ergin, Ferguson, Phil M. (1972). Corrosion of Reinforcing Steel Embedded in Structural Concrete. Center for Highway Research, The University of Texas at Austin.
14. Jin, X., Tong, J., Tian, Y., & Jin, N. (2018). Time-varying relative displacement field on the surface of concrete cover caused by reinforcement corrosion based on DIC measurement. *Construction and Building Materials*, 159: 695-703. <https://doi.org/10.1016/j.conbuildmat.2017.10.119>
15. Kivell, Anton Richard Lean. (2012). Effects of bond deterioration due to corrosion on seismic performance of reinforced concrete structures. University of Canterbury,

- New Zealand, 2012. <http://hdl.handle.net/10092/6931>. (2012).
<http://dx.doi.org/10.26021/1662>
16. Kung, P., & Comanici, M. (2014). Monitoring corrosion in reinforced concrete structures.” Proceedings of SPIE, 9113, Sensors for Extreme Harsh Environments, 91130E (5 June 2014); <https://doi.org/10.1117/12.2048828>
17. Li., C. Q., Zheng, J.J., Lawanwisut, W., and Melchers, R.E. (2007). Concrete Delamination Caused by steel reinforcement corrosion. Journal of Materials in Civil Engineering, July 2007; 19(7). [https://doi.org/10.1061/\(ASCE\)0899-1561\(2007\)19:7\(591\)](https://doi.org/10.1061/(ASCE)0899-1561(2007)19:7(591))
18. Lin, H., Zhao, Y., Ožbolt, J., & Reinhardt, H. (2017). Bond strength evaluation of corroded steel bars via the surface crack width induced by reinforcement corrosion. Engineering Structures, 2017; 152: 506-522. <https://doi.org/10.1016/j.engstruct.2017.08.051>
19. Lopez-Calvo, H., Montes-García, P., Jiménez-Quero, V., Gómez-Barranco, H., Bremner, T., & Thomas, M. (2018). Influence of crack width, cover depth and concrete quality on corrosion of steel in HPC containing corrosion inhibiting admixtures and fly ash. Cement and Concrete Composites, 88: 200-210. <https://doi.org/10.1016/j.cemconcomp.2018.01.016>
20. G. Loreto, M. Di Benedetti, R. Iovino, A. Nanni, and M. A. Gonzalez. (2011). Evaluation of corrosion effect in reinforced concrete by chloride exposure. Proc. SPIE 7983, Nondestructive Characterization for Composite Materials, Aerospace Engineering, Civil Infrastructure, and Homeland Security 2011; 79830A (18 April 2011); <https://doi.org/10.1117/12.880156>.
21. Makhlof, H.M. & Malhas, Faris. (1996). The effect of thick concrete cover on the maximum flexural crack width under service load, 93: 257-265.
22. Otieno, M. B., Alexander, M.G., and Beushausen, H.-D. (2010). Corrosion in cracked and uncracked concrete influence of crack width, concrete quality and crack reopening.” Magazine of Concrete Research, 2010; 62(6): June, 393-404. doi:10.1680/mac.2010.62.6.393. <https://doi.org/10.1680/mac.2010.62.6.393>.
23. Pettersson, K.; Jorgensen, O.; Fidjestol, P. (1996). The effect of the cracks on reinforcement corrosion in high performance concrete in a marine environment. Third CAHMET/ACI International conference on performance in marine environment (ed. V.M. Malhotra), SP 163: 185-200.
24. Petrovic, Zoran C. (2016). Catastrophes caused by Corrosion. Military Technical

- Courier, 2016; 64, No. 4. DOI: 10.5937/vojtehg64-10388. <http://orcid.org/0000-0001-8053-4034>.
25. Ravindrarajah, R. and Ong, K.,. (1968). Corrosion of steel in concrete in relation to bar diameter and cover thickness. ACI-SP100-84.
 26. Rasheeduzzafar, Al-Saadoun, S., & Al-Gahtani, A., (1992). Corrosion cracking in relation to bar diameter, cover and concrete quality. *Mater. Civ. Eng. ASCE*, 4: 327-343. [https://doi.org/10.1061/\(ASCE\)0899-1561\(1992\)4:4\(327\)](https://doi.org/10.1061/(ASCE)0899-1561(1992)4:4(327)).
 27. Shaikh, F.U.A. Effect of Cracking on Corrosion of Steel in Concrete. *Int J Concr Struct Mater* **12**, 3 (2018). <https://doi.org/10.1186/s40069-018-0234-y>
 28. S. Y. Lee et al. (2013). The Effect of Cover Thickness to Corrosion Characteristics of Reinforced Steel Bar Embedded in Mortar Specimen (W/C:0.6) Aged 5 Years in Seawater. *Advanced Materials Research*, Vols. 785-786, pp. 1176-1180. <https://doi.org/10.4028/www.scientific.net/AMR.785-786.1176>
 29. Tapan, M., & Aboutaha, R. (2011). Effect of steel corrosion and loss of concrete cover on the strength of deteriorated RC columns. *Construction and Building Materials*, 25(5): 2596-2603. <https://doi.org/10.1016/j.conbuildmat.2010.12.003>.
 30. Tian W., et al. (2010). Study on the influencing factors of steel corrosion in cracked concrete. *Fracture Mechanics of Concrete and Concrete Structures -Assessment, Durability, Monitoring and Retrofitting of Concrete Structures.- B. H. Oh, et al. (eds) © 2010 Korea Concrete Institute, Seoul, ISBN 978-89-5708-181-5. (2010)*.
 31. Uddin, Faiz & Shaikh, Ahmed. (2018). Effect of Cracking on Corrosion of Steel in Concrete. *International Journal of Concrete Structures and Materials*. DOI 10.1186/s40069-018-0234-y. ISSN 1979-0485 / eISSN 2234-1315.
 32. Vidal, T., Castel, A., & François, R. (2004). Analyzing crack width to predict corrosion in reinforced concrete. *Cement and Concrete Research*, 34(1): 165-174. [https://doi.org/10.1016/S0008-8846\(03\)00246-1](https://doi.org/10.1016/S0008-8846(03)00246-1).
 33. Whitmore, D. (2018). Corrosion Protection of Reinforced Concrete Columns and Piles in a Marine Environment. NACE International. CORROSION 2018, 15-19 April, Phoenix, Arizona, USA. NACE-2018-10558.
 34. Yang, S., Li, K., & Li, C. (2018). Numerical determination of concrete crack width for corrosion-affected concrete structures. *Computers & Structures*, 207: 75-82. <https://doi.org/10.1016/j.compstruc.2017.07.016>.
 35. Zhao, Y., & Jin, W. (2006). Modeling the Amount of Steel Corrosion at the Cracking of

Concrete Cover. *Advances in Structural Engineering*, 9(5): 687-696.
<https://doi.org/10.1260/136943306778827556>.