



TO DETECT LOAD DEVIATION OF THE VEHICLE AND MONITORING BATTERY VOLTAGE BY USING GSM

B. Dharshini^{*1}, E. Elakkiya Sowdambiga², S. Karthikeyan³, C. Sathish Kumar⁴ and A. Liyas Basha⁵

^{1,2,3}Final Year of Electrical & Electronics Engineering, AVS Engineering College, Ammapet, Salem 636003.

^{4,5}Assistant Professor, Electrical and Electronics Engineering AVS Engineering College, Ammapet Salem 636003.

Article Received on 17/01/2019

Article Revised on 07/02/2019

Article Accepted on 28/02/2019

***Corresponding Author**

B. Dharshini

Final Year of Electrical & Electronics Engineering,
AVS Engineering College,
Ammapet, Salem 636 003.

ABSTRACT

The Primary Objective Of This Paper Is Avoid Accident And Provide Protection To Human And Heavyweight Load , Load Carrying Vehicle By Using Internet Of Things Applications. In Present Scenario Road Side Accident Are Increased In The Casus For Various Factors Like Wise Heavy Load Carrying Vehicle, Without Adaptive Based Vehicle.

Heavy Load Means Bulky Sugar Cans, Automobile Parts, Small Rocks, Power System Equipment's. Day By Day The Industrial Transportation Developed Also Some Difficulties Increased Transportation Time The Difficulties Are Damaged Load, Vehicle Body, Human. There For We Are Introduce One Novel Scheme Based Upon Microelectronics And Sensors. The Proposed System Is Carry With Serviceable And Non -Serviceable Functions. Recent Technology And Developed Embedded Base Adaptive Control Methodology But Some Other Features Not Inserted Adaptive Embedded Vehicle. Other Features Like Wise Heavy Load Carrying Vehicle Travelling To Tribal Area Corner Point Turning Corner Area Time Static Loads Are Dynamically Move To Out Vehicle Right Or Left Side Consequently Vehicle Also Take More Pressure Or Stress Ssafter Vehicle Body Is Damaged, Driver Also Affected From Load Adjusting Time. We Get Awareness From This Concept Continuously Developed One Part Of Work That Means Load Adjusting Time Alarm Sent To Driver, Vehicle Owner And Control Or Break Vehicle Automatically . Our Project Contain Arduino

Interfaced With Load Cell , Liquid Crystal Display, GSM , Alarm , Driver Circuit , Battery , Amplifier It Also Automatic Vehicle Breaking Parts, Driver Circuit With Alarm Unit. This Work Also Helped To The Trolley Agency And Save Human Beings The Proposed Scheme Also Used Embedded C Set Of Rules And Steps. End Of The Result Will Be Got MPLAB IDE.

KEYWORDS: Embedded C, Amplifier, Arduino MC, LCD, GSM.

1. INTRODUCTION

Self-Governing Vehicle Developed Has Advanced Suggestively In Now Days. Computerized Features Have Already Provided Vehicles With Some Computerised Features (E.G., Self-Starting) And Crack Anticipation Structures Such As Computerised Decelerating, Forward Crash Warning, Lane Leave-Taking Warning, And Sightless Spot Observing.^[1,2] Computerized Features Analysis And Directing Have Activated In Various Countries In World. Computerised Testing On Highways Has Been Endorsed In Some Circumstances In The United State America. In Australia, Computerized Vehicle Testing Has Been First Developed In South Australia's Highways In 2014. The Bazaar Permeation Rate Of Computerised Vehicle Is Estimated To Be Amongst 27% And 87%. Most Crossbreed And Conformist Vehicles Regularly Include An Computerised Idle Stop System. Cvs Have The Potential To Suggestively Improve High Way Safety As The Mainstream Of Clatters Are Linked To Driver Faults, Tiredness, Alcohol, Or Drugs. It Is Also Expected That Cvs Can Travel With Shorter Progressions Due To Developed Safety, Foremost To Exploited High Ways And Juncture Abilities. Cvs Would Always Provide Developed Motion To The Restricted, Those Who Are Too Un Older To Get-Up-And-Go, And Older Persons. Other Probable Merits Of Cvs Comprise Improved Productive Purpose Of Driving Time, Scarcer Discharges, Improved Fuel Proficiency, And Minimized Places Costs Instigating Cvs Within The Highways Network Has The Probable To Suggestively Minimize The Number Of Clatters Produced By The Drivers Through The Regular Elimination Of Human Governor. By At The Present, Most Vehicle Manufacturing Company Are Increasing The Develop Mmentation And Inserting Various Features Such As Adaptive Travel Governor And Vehicle Stopping Assistance That Enables The Vehicle To Stop Itself With Minimum Human Involvement. Various Of These Driver Assistance Structures Are Partially Computerised, Meaning That Driver Involvement Is Still Needed. Though The Develop Mmentation Of Computerised Structures Has Maximized In Present Years, Fully Cvs Are Yet To Be

Officially Arrayed On A Large Scale Within The Highways System Internationally. Safety Merits Of Fully Cvs Would Not Be Increased Without A High Permeation Rate Of Cvs. It Should Be Well-Known That Even As Unbroken Implemented. In Our Project Scheme Is Contain One Advanced Features That Means We Are Generally Now Heavy Load Carrying Vehicle Moving Time Load Will Be Adjusting Left Side Or Right Side That Time Vehicle And Load Cell And Driver Can Be Affected Consequently Occur Some Losses Likewise Load Cell Losses, Driver Accident And Also Vehicle Full Body Will Be Damaged. There For We Are Created One New Computerized Structure. Mostly Vehicle Moving Time Heavy Static Load Will Be Move Dynamically In Tribal Region In Above Process Occurring Time We Are Inserting Internet Of Things Applications By Control Load Cell Adjustment And Decelerating Vehicle, Sent Alarm To Driver. Above System Integrating With Already Developing Scheme This System Is Mainly Used To Computerized Stop And Start Again The Engine In Order To Maximize The Fuel Proficiency Depending On Conservational And Vehicle Circumstances. The Computerized Idle Stop System Is Actuated Once The Vehicle Fast-Tracks From A Static Condition At Any Crossing Point After A Discontinuing Point. The Vehicle Engine Automatically Controls Off, And Start Again When The Driver Wants To Drive From The First Location. The Computerized Idling Break System Normally Uses An Electric Motor To Start Again The Engine From The Cessation Condition. It Has The Ability To Minimize CO₂ Emissions By Up To 7% Compared To Conventional Vehicles Without An Auto Indolent Break Function. Stopping And Starting An Engine Is A Humble Principle, But Doing So Whilst Holding The Vehicle Aspects, Drivability, And Ensuring That The Behavior Of The Idle Stop System Is Natural To The Driver Makes It A Complex Task. Most Of The Present Research Is Directing On The Computerized Idle Stop To Improve The Fuel Efficiency And Emission Rate And Improving Control Functions. However, Most Scientists Have Ignored The Performance Of The Vehicle's System While Discontinuing And Driving Difficult. Vehicle Drivers Are Experiencing Difficulties When Stopping And Start Again On Hills And Vehicles Driven By Inexpert Drivers May Even Slip A Similar Problem Exists In Vehicles Equipped With The Auto Idle Stop, Whereby They Need To Adapt To The Changes In External Driving Circumstances. Even Though The Auto Idle Stop Has The Ability To Start Again The Vehicle From The Termination Condition, The Issue With The Rollback Condition Has Still Not Been Solved In Most Research Analysis. Therefore, A Control Strategy Is Greatly Required In Order To Overcome The Inadequacies In Current Curbside Vehicles. The Technologically Advanced System Should Have The Capacity To Reduce The Slowing Down And At The Same Time Minimize The Rollback

While Driving On A Road With An Incline. One Of The Computerized Study Works Is To Improve Uphill Driving Condition Which Falls Under Safety Phases. In Studies About The Initial Control Of Electric Vehicles, An Assist System Known As Hill Start Assistance Has Been Developed In Commercial Vehicle Applications. In This Research, The Authors Have Shown That Good Mechanical Possessions Of The Electric Motor Could Obtained By Using Double Closed-Loop Control Stratagems. Implemented Slope Recognition By Simplifying The Vehicle Longitudinal Dynamic Equation, And Then A Observer Was Designed To Recognize The High Way Slope Online In Order To Meet The Necessities Of Safety And Driving Ease In The Hill Start Process.

2. MATERIAL AND METHODOLOGY

The Novel Protection Scheme Contain Includes More Than A Few Stages Viz. Detail Acquisition, Pre-Processing, Signal Functioning And Also Using Different Types Of Components. These Are Listed Based On Some Functions Such As Power Supply Unit Also Contain Many Converter Parts There Are Step Down Transformer By Using Step Down The Incoming Voltage Based On Arduino Configuration And Also Using Transformer And Rectifier Because PICMC Only Receive Direct Current Only Consequently Bridge Rectifier Output Of Direct Current Flow To Filter Circuit Because Bridge Rectifier Generate Direct Current With Ripple Content Therefor Filter Circuit Eliminated Ripple Content From Direct Current Output Finally The Dc Power Flow To Voltage Regulator And Arduino MC Vss Pin Shown In Figure 1. Reaming Parts Is Art Of This Project transducer and strain gauge By Purpose Of Sensing, alarm and Driver Circuit And Relay liquid crystal display , During Right Time To send alarm and message to driver And Also Using UART,GSM Module For Communication Purpose, Panic Alert System Generate Alarm During Robbery Time. The arduino Only Work For Panic Situation Not For Normal Condition. The Relay Also used computerised vehicle breaking system normal condition vehicle can move freely. relay Have Fixed Contact And Moving Contact With Some Gap Abnormal Condition Only Attract Two Above Contact For Respected Work.

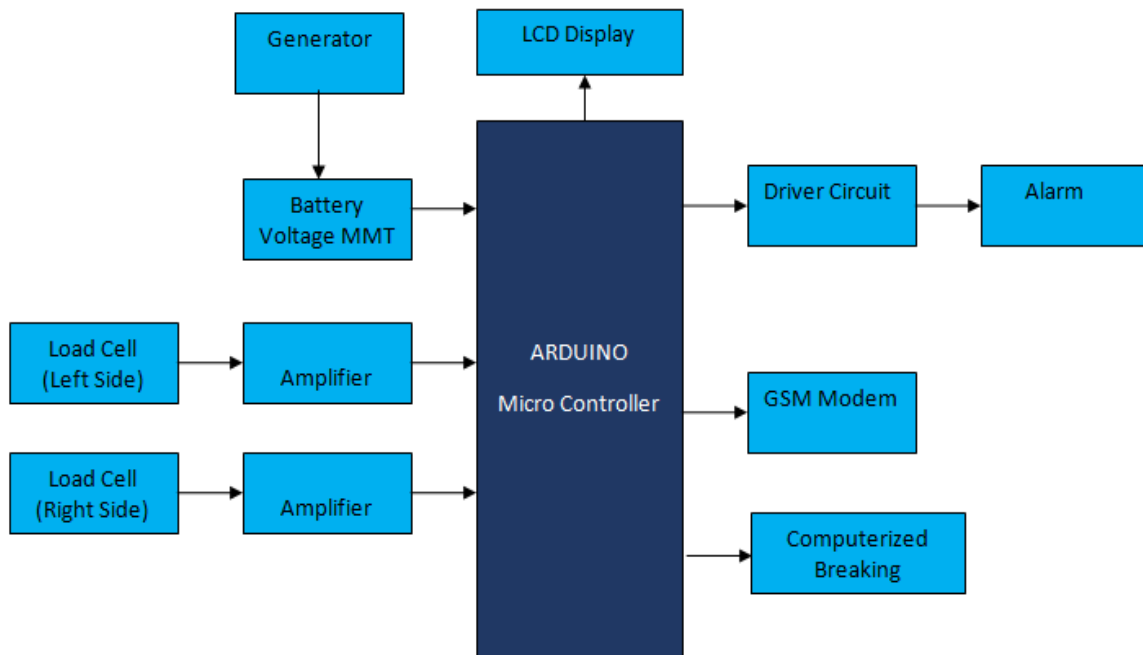

Figure 1: Typical Block Diagram For load cell & Safety System, Processing And Analysis.

3. Arduino MC Pin Configuration with Interfacing Line

Various microcontroller available in current technology world but we are using for arduino because various features and benefits present in arduino. Arduino can be used to interconnect with a load cell transducer and driver circuit liquid crystal display and GSM, The Arduino microcontroller provides Universal asynchronous receiver transmitter with serial communication which can be done using digital pin 0 (Receiver pin) and digital pin 1 (Transmitter pin) shown in figure 2. An Arduino on the board channels this serial communication over Universal synchronous bus and appears as a fundamental com port to software on the processor. The Arduino firmware uses the standard USB COM drivers, and not need external driver is. However, on Windows, a in file is required. The Arduino software includes a serial observer which allows simple literal data to be sent to and from the Arduino board. There are two receiver and Transmitter pins LEDs on the arduino board which will flash when data is being communicated via the USB-to-serial chip and USB connection to the processor. A Software Serial reference library allows for serial announcement on any of the Uno's alphanumeric pins. The arduino also supports Inter integrated circuit and Serial peripheral interface communication. The Arduino software includes a Wire library to simplify use of the inter integrated circuit protocol bus.

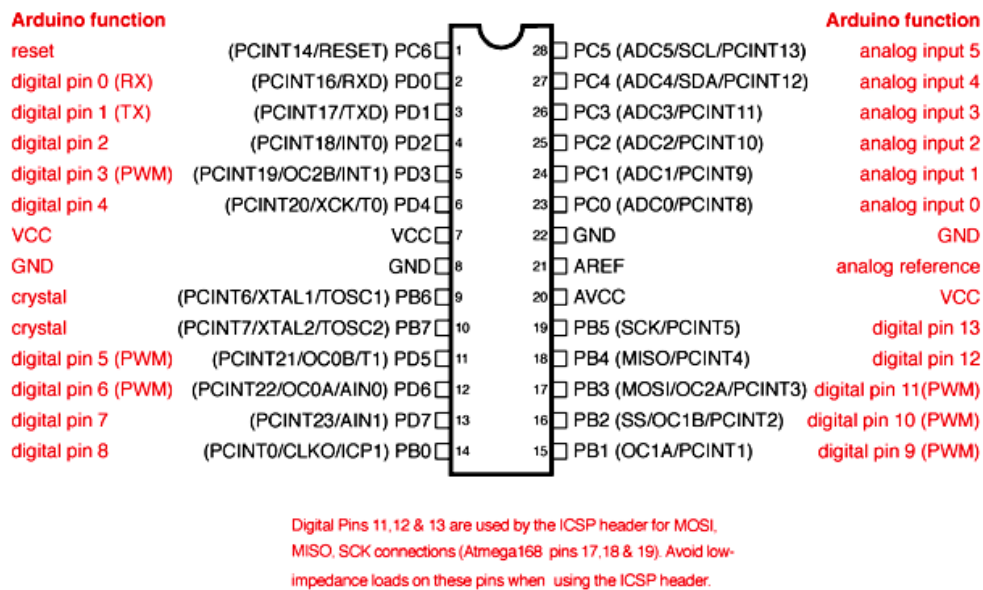

Figure 2: Arduino MC Pin Configuration.

4. Novel load cell and vehicle safety System

Alternate The Already Existing System To inserting some feature heavy load carrying vehicle System. This Novel System Consists Of Digital Display, load cell transducer, driver circuit, GSM, amplifier, power supply unit Interfacing With Arduino MC shown in figure 3. The load cell is One Part Of transducer used likewise strain gauge is convert mechanical moments to electrical signal. the electrical signal is very weak there for we are using amplifier by purpose of amplify weak signal into strong electrical signal. finally the electrical signal flow arduino. the arduino will programmed by embedded C. only arduino work condition occurring time the load may move over left or right side time arduino will send output to driver circuit and alarm, message communication, in worst case load cell may move over left side or right side vehicle will be breaking automatically by using relay function. How means Overloading is a big problem in the trucking sector. A relatively large number of infringements are related to weights of heavy goods vehicles. On average, one in three vehicles checked is overloaded. Overweight vehicles lead to all sorts of negative issues, e.g. related to road safety, driver's safety, road degradation, environment and competition. Load cell used to check the load balance in both side and load balance high in anyone side to indicate the alarm and send the SMS user using GSM Modem. Battery is the main electric power storage element in vehicle and its power can be utilized by accessories can be operated by electricity. Maximum power is utilized by starter-motor during starting of the engine from rest position. During engine running time, these electrical loads are supplied by vehicle

generator. Therefore, it is not permissible for the vehicle generator to fail in running condition. In recent years, due to the expansion of the vehicles' transportation system and concerns about the lack of accurate calculations of vehicle weight, a system that is able to calculate the vehicle's weight at any moment, it seems necessary. Therefore the design and implementation of modern systems for monitoring and control of these devices to make quick decisions and plan codified is essential. The system discussed herein mainly aims to monitor load weight balance, generated voltage and displaying the message by identifying the condition of generator whether vehicle battery is being charged properly, poorly or not charging.

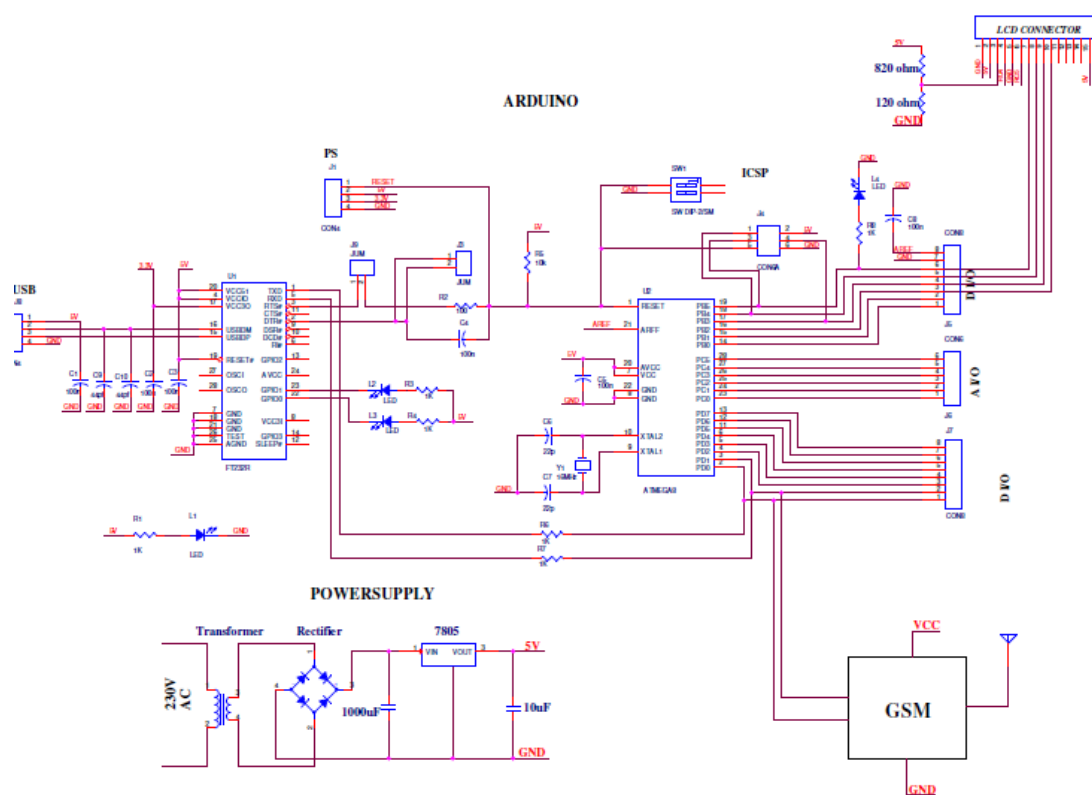

Figure 3: Arduino MC With Interfacing External Peripherals.

5. RESULTS AND DISCUSSION

The Results Which Are Obtained From Software And The Hardware Work Done Are Discussed Below- The Program Which Is Obtained From MPLAB Is Divided Into Various Parts But We Only Representing Coding Screen Shown In Figure 5.

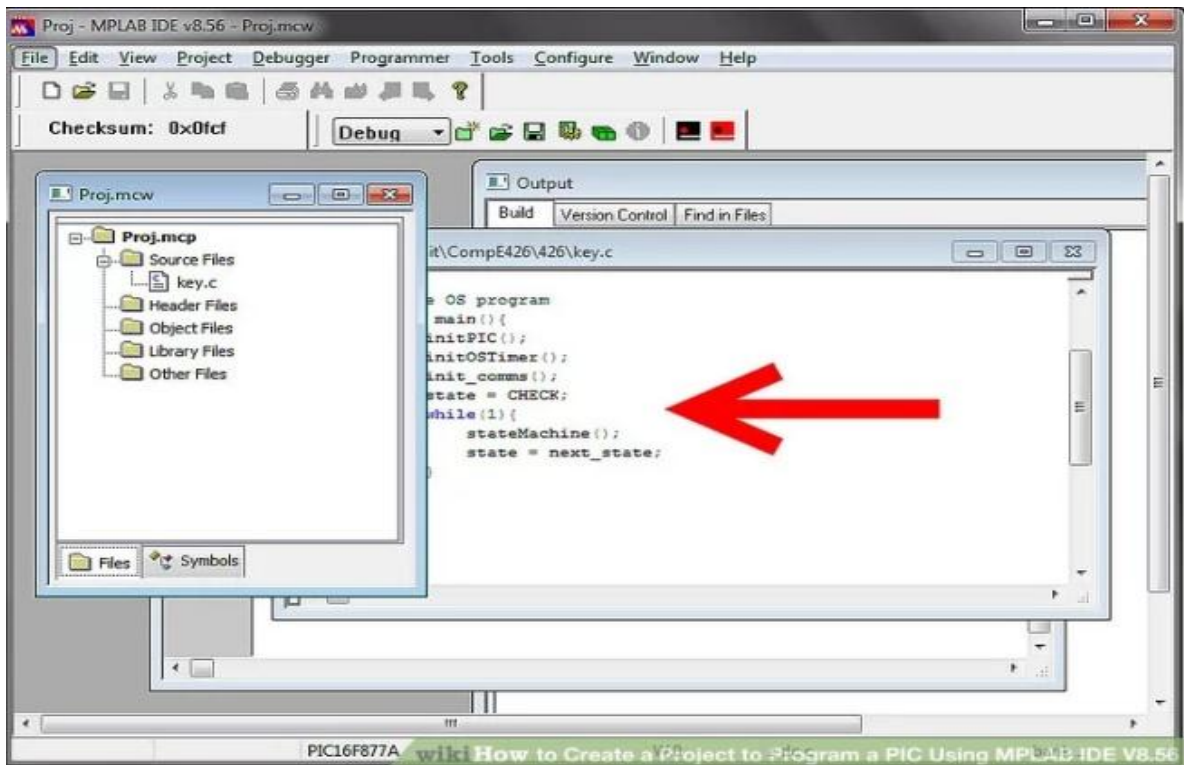

Figure 5: MPLAB Programming File.

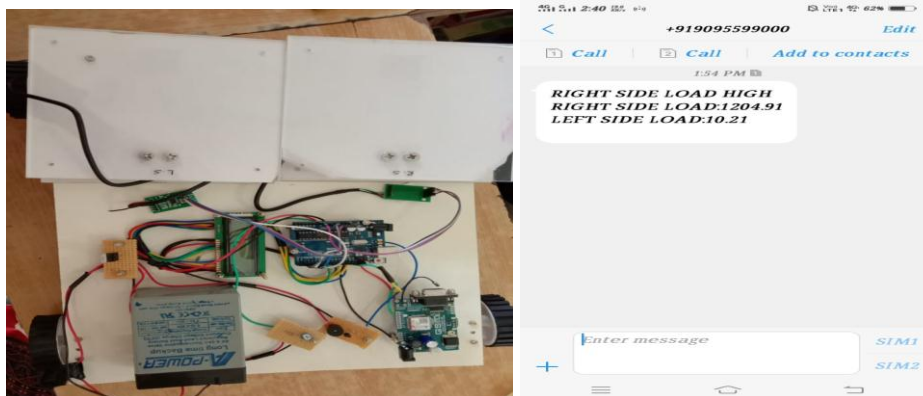

Figure 6&7: Novel Prototype Model Load Deviation Of The Vehicle System And Output.

The Novel Prototype Model Security System Is Shown In Figure 6 & 7, Which Shows The Interfacing With arduino MC And Some External Peripherals Likewise Relay, load cell, driver circuit, GSM, UART Etc. One Of The Primary Objectives Is To Reduce The Wastage Memory From Arduino MC. For This Various Signal Functioning Methodology Are Being Adopted.

6. CONCLUSION

This Paper Presents An Novel load cell deviation of vehicle system. This Is Based On Embedded C Process, To Meet The Requirement Of Current Major Security Application Of The Protection Purpose. There Are Advantages As Follows. The Functioning Signal Can Be Privacy Is An Issue And Also Low Cost Design. There are various methods for measuring the weight of the load of the vehicles, like scales but there are many disadvantages in this method: it is not only expensive but also not possible to measure the weight of each axle individually. Therefore making a weight sensor that can measure the weight of the vehicle with the extra load, seems to be necessary. Several equipment have been designed for automatic vehicle load monitoring system and celestial navigation monitoring system, but the system which we designed has these qualities: a weight sensing device attached to a base of a vehicle, and wherein the load sensing device is a load cell; a compression spring involved to the weight sensing device and to a suspension spring of the vehicle; a voltage conversion unit attached to the weight sensing device to convert an output resistance of the load cell into a voltage; an automatic vehicle location data and a voltage conversion unit; and a central server connected to receive a vehicle location data and a voltage data for computing a vehicle load at an instant; wherein the vehicle location data and the vehicle load at any instant is communicated simultaneously to a driver of the vehicle.

REFERENCES

1. HLDI, *Honda Accord collision avoidance features: an update. Bulletin Vol. 31. No. 16*, Highway Loss Data Institute, InsuranceInstitute for Highway Safety, Arlington, Va, USA, 2014.
2. J. Bierstedt, A. Gooze, C. Gray, J. Peterman, L. Raykin, and J. Walters, "Effects of Next-Generation Vehicles on Travel Demand and Highway Capacity," FP Think, 2014.
3. DPTI, *SA becomes first Australian jurisdiction to allow on-road driverless car trials*, Department of Planning, Transport and Infrastructure, 2016.
4. T. Litman, *Autonomous Vehicle Implementation Predictions: Implications for Transport Planning*, Victoria Transport Policy Institute, 2015.
5. P. Bansal and K. M. Kockelman, "Forecasting Americans' longterm adoption of connected and autonomous vehicle technologies," *Transportation Research Part A: Policy and Practice*, 2017; 95: 49–63.

6. BITRE, *Fatal road crashes in Australia in the 1990s and 2000s: crash types and major factors*, Bureau of Infrastructure, Transport and Regional Economics, Canberra, Australia, 2011.
7. NHTSA, *National Motor Vehicle Crash Causation Survey*, National Highway Traffic Safety Administration, U.S. Department of Transportation, 2008.
8. S. E. Shladover, “Cooperative (rather than autonomous) vehicle-highway automation systems,” *IEEE Intelligent Transportation Systems Magazine*, 2009; 1(1): 10–19.
9. R. Hoogendoorn, B. Van Arem, and S. Hoogendoorn, “Automated driving, traffic flow efficiency, and human factors,” *Transportation Research Record*, 2014; 2422: 113–120.
10. M. A. S. Kamal, J.-I. Imura, T. Hayakawa, A. Ohata, and K. Aihara, “A vehicle-intersection coordination scheme for smooth flows of traffic without using traffic lights,” *IEEE Transactions on Intelligent Transportation Systems*, 2015; 16(3): 1136–1147.
11. L. T. Truong, C. de Gruyter, G. Currie, and A. Delbosc, “Estimating the trip generation impacts of autonomous vehicles on car travel in Victoria, Australia,” *Transportation*, 2017; 44(6): 1279–1292.
12. D. Milakis, B. Van Arem, and B. Vanwee, “Policy and society related implications of automated driving: A review of literature and directions for future research,” *Journal of Intelligent Transportation Systems: Technology, Planning, and Operations*, 2017; 21(4): 324–348.
14. S. Childress, B. Nichols, B. Charlton, and S. Coe, “Using an activity-based model to explore possible impacts of automated vehicles,” *Transportation Research Record: Journal of the Transportation Research Board*, 2015; 2493: 99–106.
15. D. J. Fagnant and K. Kockelman, “Preparing a nation for autonomous vehicles: Opportunities, barriers and policy recommendations,” *Transportation Research Part A: Policy and Practice*, 2015; 77: 167–181.
16. P. Koopman and M. Wagner, “Autonomous vehicle safety: an interdisciplinary challenge,” *IEEE Intelligent Transportation Systems Magazine*, 2017; 9(1): 90–96.
17. V. V. Dixit, S. Chand, and D. J. Nair, “Autonomous vehicles: disengagements, accidents and reaction times,” *PLoS ONE*, 2016; 11(12). Article ID 0168054.
18. P. Rau, M. Yanagisawa, and W. G. Najm, “Target crash population of automated vehicles,” in *Proceedings of the In 24th International Technical Conference on the Enhanced Safety of Vehicles (ESV)*, Gothenburg, Sweden, 2015.
19. B. Schoettle and M. Sivak, *A Preliminary Analysis of Real- World Crashes Involving Self-Driving Vehicles*, The University of Michigan, Ann Arbor, Mich, USA, 2015.