

ANFIS CONTROLLER BASED PF IMPROVEMENT FOR INDUCTION MACHINE USING FLYING CAPACITOR MULTI LEVEL INVERTER

*¹D. Kalidass, ²S. Gokul Raj, ³A. Gnanaprakash and ⁴M. Arunchandru

¹Assistant Professor, EEE Department, Muthayammal College of Engineering, Rasipuram.

^{2,3,4}UG Students, EEE Department, Muthayammal College of Engineering, Rasipuram.

Article Received on 04/02/2019

Article Revised on 57/02/2019

Article Accepted on 17/03/2019

*Corresponding Author

D. Kalidass

Assistant Professor, EEE
Department, Muthayammal
College of Engineering,
Rasipuram.

ABSTRACT

Energy thing development presents familiar blessings to keep away from bad electricity aspect effect and to reduction bill fee. Passive and active strength thing correction are the two techniques presently the use of energy element correction strategies. This thesis try to develop an inverter with applied active strength issue correction

method for improve of the strength trouble. MATLAB software program application is used to layout ANFIS controller to manipulate electricity element on induction machine with the aid of using modern-day-day and voltage supply inverter from single section rectifier. The combination of modern-day and voltage supply inverter is called Flying capacitor Multi level inverter. This system integrates the concept of ANFIS and Flying capacitor Multi level inverter for controlling the output voltage of DC-AC inverter and also looking to improve an efficiency of the Flying capacitor Multi level inverter via transient operation. in this planned model, a Flying capacitor Multi level inverter is used for active % and contemporary and voltage parameter having advantages of being bodily remotes shape, can function as each step up and step down Flying capacitor Multi level inverter and having most effective one step processing for modern-day, voltage regulation and percent. A model for strength aspect Correction may be done the use of the MATLAB software program.

KEYWORDS: ANFIS Controller, Flying capacitor Multi level inverter, Induction motor, MATLAB, Power Factor Controller.

1. INTRODUCTION

The main goals of this observe is to layout a strength saving scheme for an industrial distribution network. This may be done by means of lowering the community losses and improving the main electric load operation to a better efficiency level. The linear aggregate of genuine electricity and reactive strength is called apparent power. Low power thing isn't that a great deal problem in domestic's location however it will become a trouble in industry in which a couple of big automobiles are used so there's requirement to correct the electricity issue. There are numerous advantages to having power thing correction. The strength detail control is one of the most important instructions in energy electronics research. Lately, the paintings on this area have been facilitated thru the development of the modern-day supply inverter using easy switching strategies. In the remaining decade, a few researchers have manifested hobby in improving the performances of the wound induction tool by way of manner of using current deliver inverter.

The handiest viable source of excitation in an induction gadget is the stator input. The induction machine therefore needs to operate at a lagging electricity thing. This strength factor could be very low at no load and increases to about 85 to 90 percent at full load, the development being as a result of the multiplied real-energy necessities with increasing load. The presence of air-gap between the stator coil associated rotors of an induction machine greatly will increase the reluctance of the magnetic circuit. Induction machine speed can be control via using fuzzy good judgment controller and the simulation model of Induction machine power the usage of Matlab/Simulink.

The voltage source inverter (VSI) fed drives are most broadly used in low and medium electricity applications, however now not used extensively in high power applications. Nowadays CSI drives are rent self commutating devices together with gate turn-off thyristors (GTOs) in place of SCRs as within the past. To get stepped forward output currents and voltages Pulse width modulation (PWM) strategies are used.

The effectiveness of the proposed control was demonstrated through comparison with some commonly employed control methods, through an extensive set of simulations using MATLAB/ Simulink Sim Power Systems toolbox. All the above papers explained fuzzy logic

controller based power factor improvement of induction machine by using current source inverter. But in this paper explain voltage and current is control in the inverter itself and controlled voltage and current is given to the induction machine to maintain high power factor through anfis controller.

2. Induction Machine Drive

An electrical motor is such an electromechanical device which converts electrical electricity into a mechanical strength. Maximum widely used motor is 3 phase induction machine as this kind of motor does not require any beginning device or we are able to say they're self beginning induction motor. For better know-how the precept of 3 phase induction motor, the basic constructional characteristic of this motor need to be known to us. This Motor consists of two most important elements.

A. Stator

Stator of three phase induction machine is made from numbers of slots to assemble a 3 section winding circuit that is linked to a 3 phase AC supply. Stator diagram is shown in fig. 1. The 3 section winding are arranged in this kind of way inside the slots that they produce a rotating magnetic field after 3 Phase. AC supply is given to them.

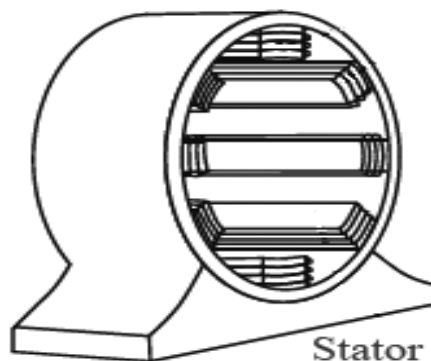

Fig. 1: Diagram of stator.

B. Rotor

Rotor of 3 phase induction machine includes cylindrical laminated middle with parallel slots that can bring conductors. Conductors are heavy copper or aluminum bars which suits in every slots & they're brief circuited via the cease rings. Squirrel cage rotor is shown in fig. 2. The slots are not exactly made parallel to the axis of the shaft but are slotted a touch skewed due to the fact this association reduces magnetic buzzing noise & can avoid stalling of motor.

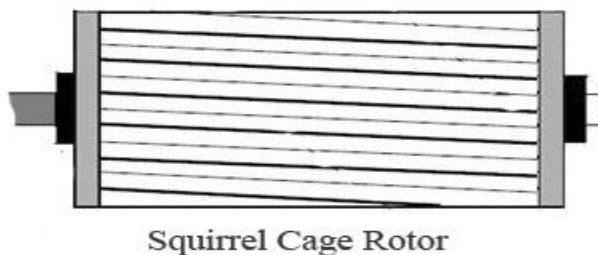

Fig. 2: Diagram of Squirrel cage rotor.

The difference between the synchronous speed (N_s) and actual speed (N) of the rotor is called as slip.

$$\% \text{ slip } s = \frac{N_s - N}{N_s} \times 100$$

The rotational speed of the rotating magnetic field is called as synchronous speed.

$$N_s = \frac{120 \times f}{P} \quad (\text{RPM})$$

Where, f = frequency of the supply

P = number of poles

Here, to send the feedback of position and speed of the motor Hall-effect sensors are used. In addition to the switching for a rated speed of the motor, an additional electronic circuitry changes the motor speed based on required application. Induction machine drive is shown in fig. 3. These speed control units are implemented with ANFIS controller to have accurate control.

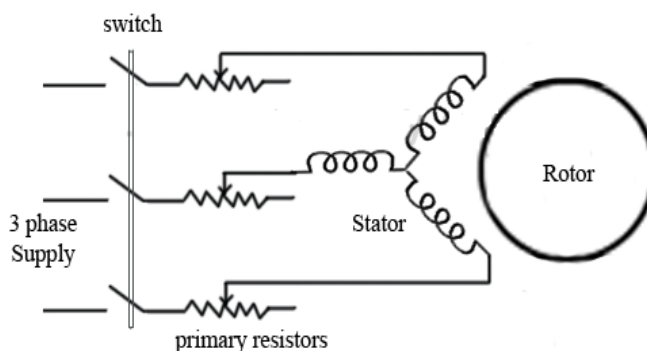

Fig. 3: Circuit diagram for induction machine drive.

3. Controllers

3.1 Anfis Controller

An adaptive neuro-fuzzy inference system or adaptive community-primarily based fuzzy inference device (ANFIS) is a form of artificial neural network that is primarily based on Takagi–Sugeno fuzzy inference machine. Because it integrates each neural networks and fuzzy good judgment standards, it has capability to capture the blessings of each in an unmarried framework. Its inference machine corresponds to a hard and fast of fuzzy IF–THEN policies which have studying functionality to approximate nonlinear features. Consequently, ANFIS is considered to be an established estimator. For the usage of the ANFIS in an extra green and most beneficial way, one can use the best parameters received through genetic set of rules.

Consider a Sugeno type of fuzzy system having the rule base

1. If x is A_1 and y is B_1 , then $f_1 = c_{11}x + c_{12}y + c_{10}$
2. If x is A_2 and y is B_2 , then $f_2 = c_{21}x + c_{22}y + c_{20}$

The structure of the ANFIS network is shown in fig 4. All computations can be presented in a diagram form. ANFIS normally has 5 layers of neurons of which neurons in the same layer are of the same function family.

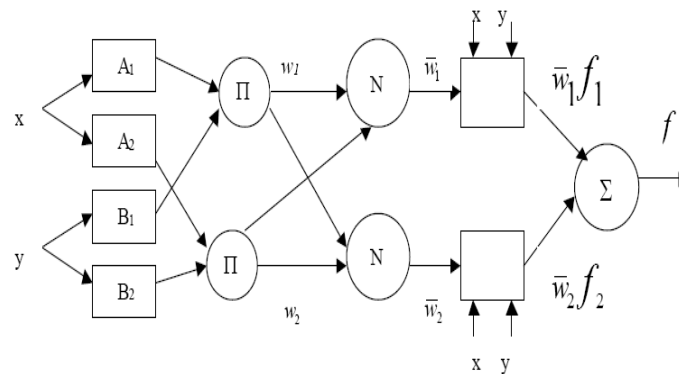

Fig. 4: Structure of the ANFIS network.

4. Modeling And Simulation Of Power Factor Improvement For Induction Motor

The proposed system using ANFIS controller is implemented for power factor improvement of Induction motor. Fig 5 shows simulation model of ANFIS controller based power factor improvement of Induction motor. This simulation model consists of four sub blocks named as Induction model block, Inverter block, controller and subsystem. The subsystem 1 for gate signal it's given in the form of angle (Θ). The performance of induction machine is analyzed

by using Mat lab. Induction machine blocks itself the EMF, current, voltage and power factor blocks are present. The duty cycle of the power electronics devices such as MOSFET, IGBT are controlled by fuzzy controller. The feedback of actual power factor value is taken from the induction machine and given to the fuzzy controller along with reference value. Simulation of power factor calculation is shown in Fig 5.

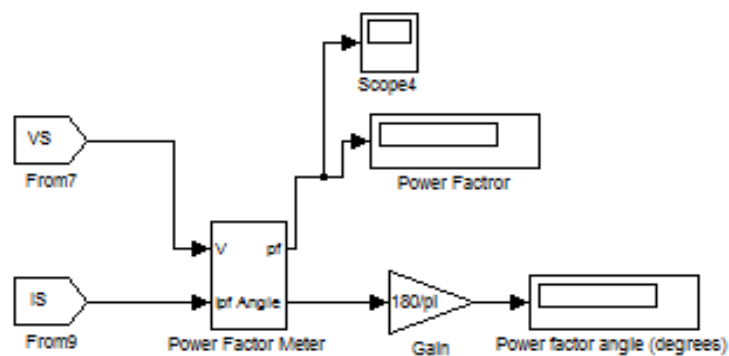

Fig. 5: ANFIC Controller.

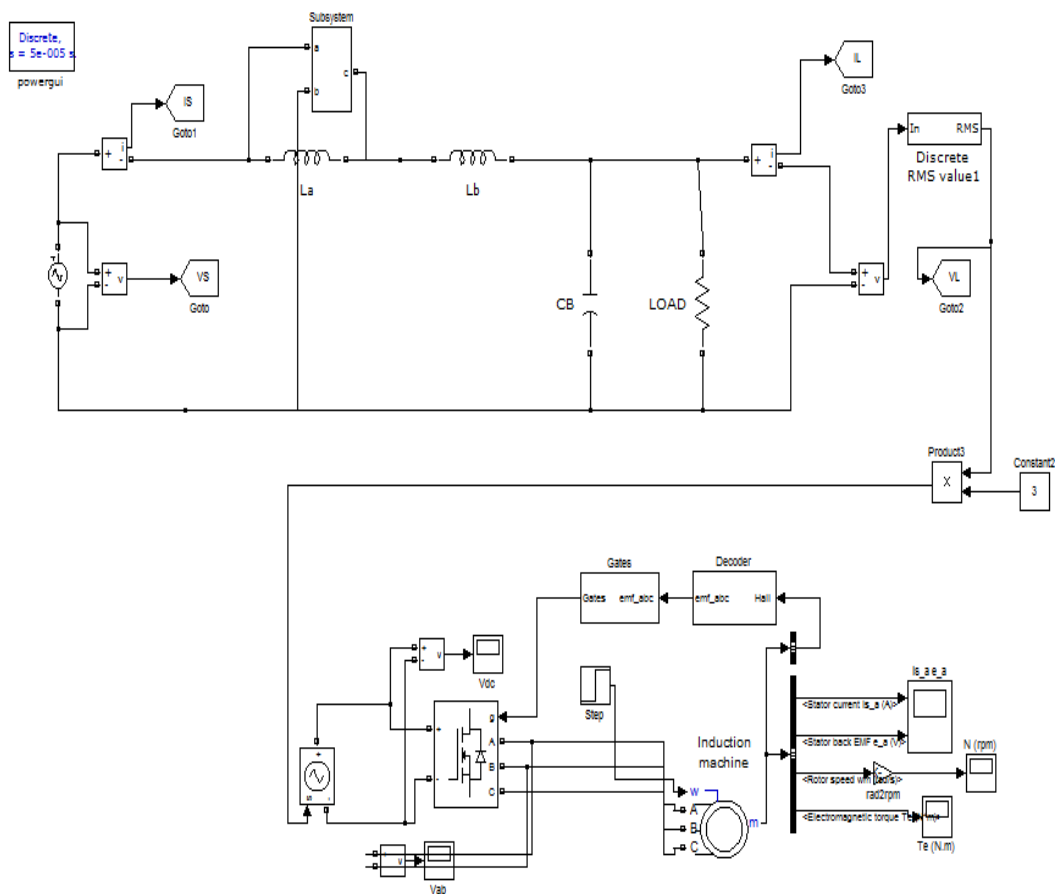

Fig. 6: Controller based Overall MATLAB Simulation circuit.

The proposed simulation version of induction machine power is showing in fig 6. The parameters of the percent based Flying capacitor Multi level inverter are designed such, that it operates in DICM to gain inherent energy component correction at ac mains. Reference voltage is calculated from controller, as it's miles at once proportional to the carried out dc hyperlink voltage at a given load. electronic commutation is based totally at the signals of position sensing corridor sensors placed in the motor.

5. Performance Analysis Of Induction Motor

5.1 Waveform of Source Voltage and Current

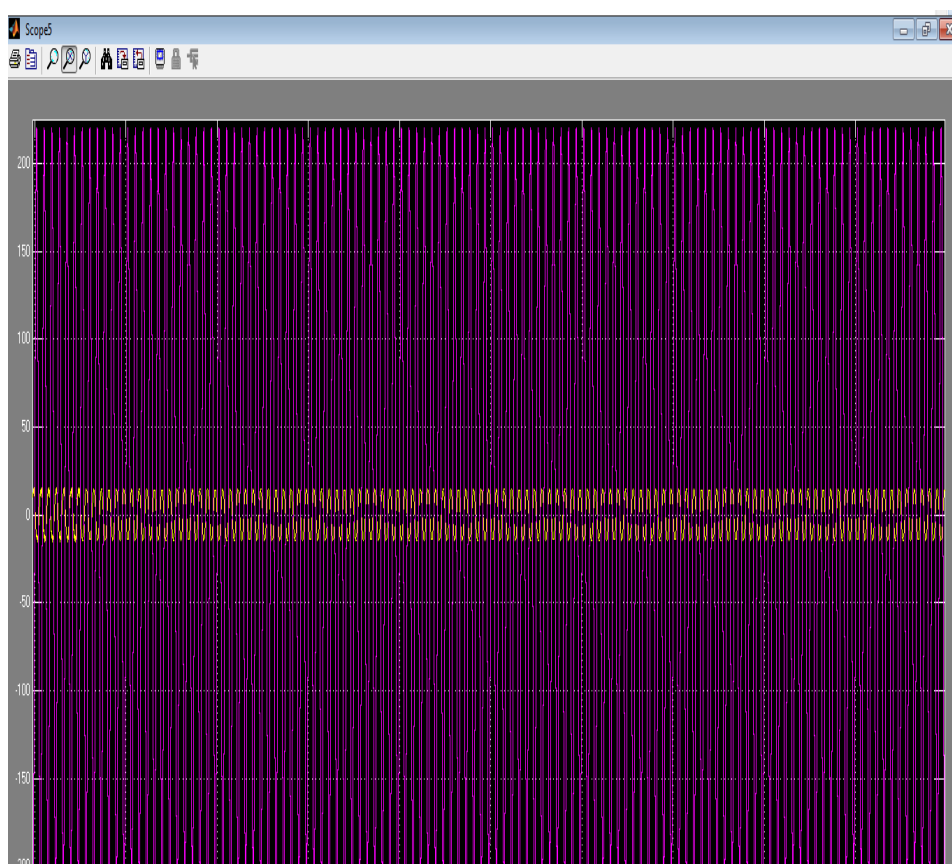

Fig. 7: Waveform of source voltage and current.

In this proposed simulation diagram, the AC source voltage of 220 V and source current of 4.12A is applied and waveforms corresponding to this ratings are obtained and displayed. Figure 5.1 shows the waveform of source voltage of 220V and source current of 4.12A.

5.2 Waveforms of Phase Voltage and Line Current

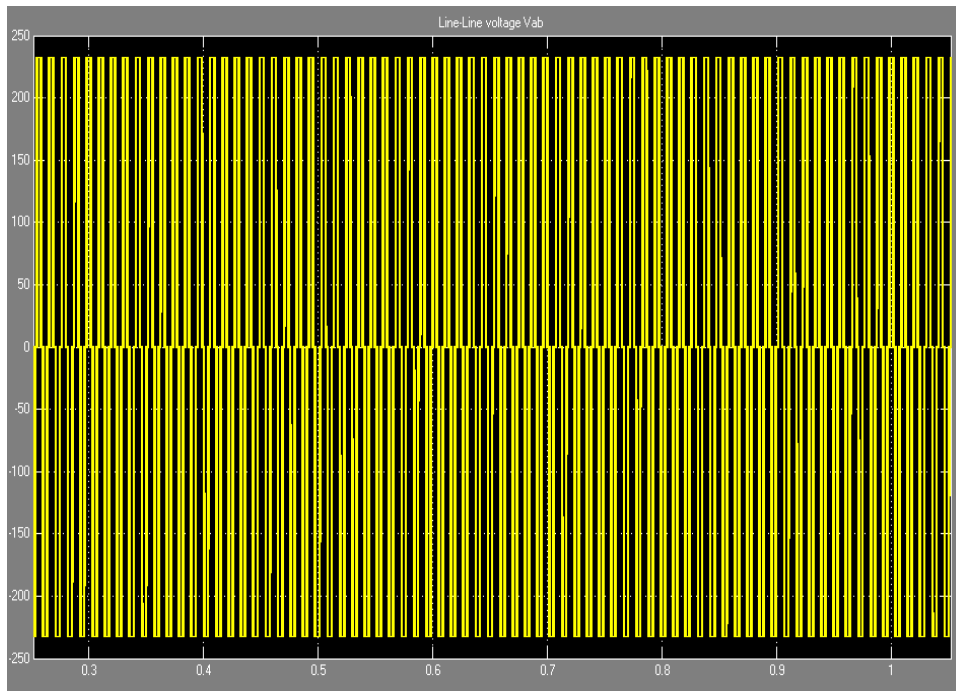

Fig. 8: Waveform of phase voltage in volts.

The waveform of phase voltage of induction machine drive is shown in figure 8 and in this, the phase voltage is given in volts and is measured in terms of time in seconds and figure 9 includes the diagram of line current of induction machine drive.

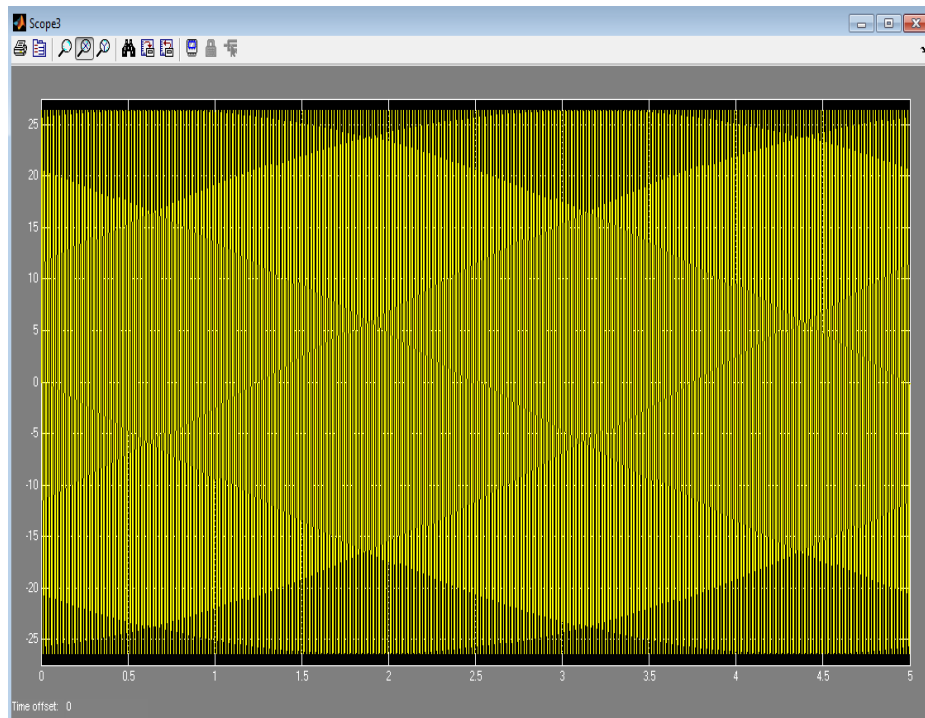

Fig. 9: Waveform of line current in amps.

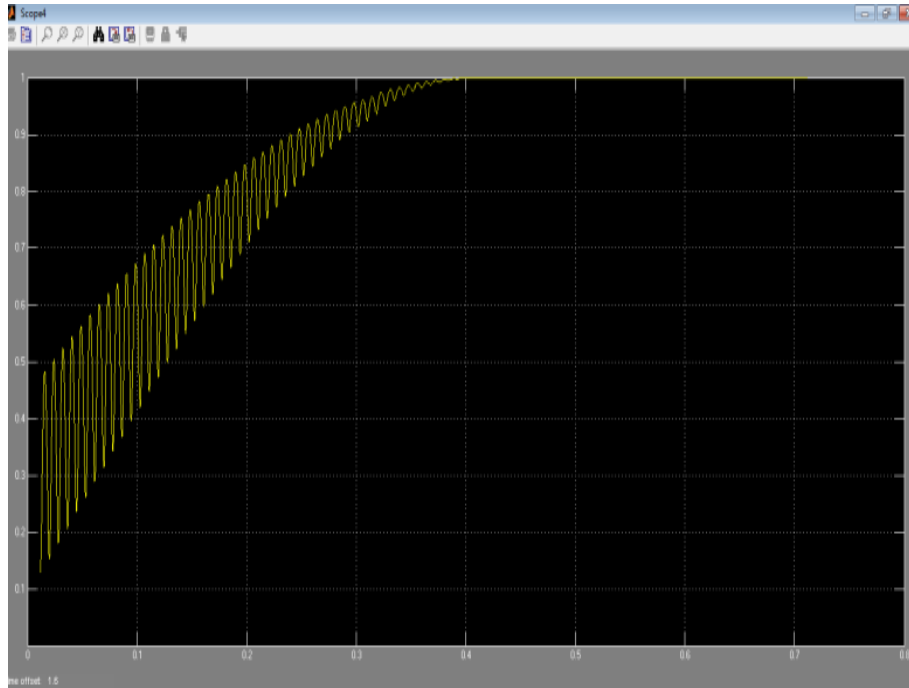

Fig. 10: Waveform power factor value.

Fig 10 shows the power factor rating when the source voltage and current is maintained at 220V and 4.02A respectively. It shows that the power factor is maintained 0.9532 in the input side of the proposed drive. On comparing the existing and proposed model, the proposed method i.e. the Flying capacitor Multi level inverter fed induction machine drive has ensured the high power factor of about 0.95 which nearly a unity power factor and also improves the performance of the system.

6. CONCLUSION

The project work has presented the Flying capacitor Multi level inverter to feed an Induction machine drive. Initially, the important characteristics of induction machine was presented as well as, its electric model necessary for the design of integrated topology. The proposed circuit is designed for CCM operation, so that the inverter could be represented as an equivalent resistance. A current sensor is used to measure the current in induction machine to reduce the low power factor. The integration of two stages reduced the system size and cost. A Flying capacitor Multi level inverter derived electricity issue correction topology for induction machine the use of ANFIS good judgment controller has been supplied. The advantages of this proposed gadget is less cost, one level of electricity conversion, easy comments manipulate, and electricity issue is nearer to team spirit. The ANFIS good judgment controller is implemented to force the inverter and it operates in non-stop

conduction mode. By designing the converter to perform in continuous conduction mode, the modern-day strain is sincerely much less and the life of the gadget may be advanced. On comparing the existing and proposed model, the proposed method i.e. the Flying capacitor Multi level inverter fed Induction machine drive has ensured the high power factor of about 0.95 which nearly a unity power factor and also improves the performance of the system. The entire System was designed and implemented in MATLAB/SIMULINK. The performance of the system for the extraordinary values of enter AC voltage has been evaluated and discovered excellent.

REFERENCES

1. Sharkawi E I, Chen M A, Vandari S V, Fisser G W, Butter N G, Vinger R J, "An Adaptive Power Factor Controller for Three Phase Induction Generator", *IEEE Transaction on Power Apparatus and Systems*, 1985; 104: 1825-1831.
2. J.Klein, M.K.Nalbant, "Power Factor Correction – Incentives, Standards and Techniques", *PCIM Conf. proc.*, 1990; 26: 28-31
3. C.Nagarajan and M.Madheswaran, 'Experimental verification and stability state space analysis of CLL-T Series Parallel Resonant Converter with fuzzy controller' - *Journal of Electrical Engineering*, 2012; 63(6): 365-372.
4. R.Raja and C.Nagarajan, "Performance Analysis of LCL-T Filter Based 2 Stage Single Phase Grid Connected Module with ANN Controller using PV Panel," *Current Signal Transduction Therapy*, 2018; 13(2): 159-167.
5. C.Nagarajan and M.Madheswaran, "Performance Analysis of LCL-T Resonant Converter with Fuzzy/PID Using State Space Analysis" *Springer, Electrical Engineering*, 2011; 93(3): 167-178.
6. E.Geetha, C. Nagarajan, "Stochastic Rule Control Algorithm Based Enlistment of Induction Motor Parameters Monitoring in IoT Applications," *Wireless Personal Communications*, 2018; 102(4): 3629–3645.
7. M.Madheswaran, C.Nagarajan, "DSP Based Fuzzy Controller for Series Parallel Resonant converter", *Frontiers of Electrical and Electronic Engineering*, 2012; 7(4): 438-446.
8. C.Nagarajan, "Single-Stage High-Frequency Resonant AC Converter Using Fuzzy Logic and Artificial Neural networks', *Conference on Emerging Devices and Smart Systems (ICEDSS)*, 2nd and 3rd March, organized by mahendra Engineering College, Mallasamudram, 2018; 30-37.

9. E Geetha, C Nagarajan, "Induction Motor Fault Detection and Classification Using Current Signature Analysis Technique", *Conference on Emerging Devices and Smart Systems (ICEDSS)*, 2nd and 3rd March, organized by mahendra Engineering College, Mallasamudram, 2018; 48-52.
10. GS SatheeshKumar, C Nagarajan, ST Selvi, "A Virtual Impedance Based Analysis of Dynamic Stability in a Micro-Grid System", *Conference on Emerging Devices and Smart Systems (ICEDSS)*, 2nd and 3rd March, organized by mahendra Engineering College, Mallasamudram, 2018; 38-41.
11. CS Lakshmi, C Nagarajan, "Neural Controlled Multi-Level Inverter Based DVR for Power Quality Improvement", *Conference on Emerging Devices and Smart Systems (ICEDSS)*, 2nd and 3rd March, organized by mahendra Engineering College, Mallasamudram, 2018; 42-47.
12. S Thirunavukkarasu, C Nagarajan, "Performance Analysis of BLDC Motor Drive for Feed Drives", *Conference on Emerging Devices and Smart Systems (ICEDSS)*, 2nd and 3rd March, organized by mahendra Engineering College, Mallasamudram, 2018; 67-70.
13. JP Daniel, C Nagarajan, "Hybrid Filter for Distorted Voltage Source in Microgrids", *Conference on Emerging Devices and Smart Systems (ICEDSS)*, 2nd and 3rd March, organized by mahendra Engineering College, Mallasamudram, 2018; 11-15.
14. K Umadevi, C Nagarajan, "High Gain Ratio Boost-Fly Back DC-DC Converter using Capacitor Coupling", *Conference on Emerging Devices and Smart Systems (ICEDSS)*, 2nd and 3rd March, organized by mahendra Engineering College, Mallasamudram, 2018; 64-66.
15. C.Nagarajan and M.Madheswaran, "Experimental Study and steady state stability analysis of CLL-T Series Parallel Resonant Converter with Fuzzy controller using State Space Analysis", *Iranian Journal of Electrical and Electronic Engineering*, 2012; 8(3): 259-267.
16. Santhana Lakshmi and C. Nagarajan, "Multiconverter Technology Based Voltage Compensation for Photovoltaic System" *Ecology, Environment and Conservation*, 2017; 23: 226-229.

17. C.Nagarajan and M.Madheswaran, "Stability Analysis of Series Parallel Resonant Converter with Fuzzy Logic Controller Using State Space Techniques", *Electric Power Components and Systems*, 2011; 39(8): 780-793.
18. C.Nagarajan, M.Muruganandam and D.Ramasubramanian – 'Analysis and Design of CLL Resonant Converter for Solar Panel - Battery systems- *International Journal of Intelligent systems and Applications*, 2013; 5(1): 52-58.
19. C.Nagarajan and M.Madheswaran, "Experimental Study and Comparative Analysis of CLL-T and LCL-T Series Parallel Resonant Converter with Fuzzy/ PID Controller", *Journal of Electrical Engineering*, 2011; 11(3): 122-129.
20. C.Nagarajan and M.Madheswaran "Analysis and Simulation of LCL Series Resonant Full Bridge Converter Using PWM Technique with Load Independent Operation" has been presented in ICTES'08, a IEEE / IET International Conference organized by M.G.R.University, Chennai, 2007; 1: 190-195.
21. Nagarajan, M.Madheswaran and D.Ramasubramanian, "Development of DSP based Robust Control Method for General Resonant Converter Topologies using Transfer Function Model," *Acta Electrotechnica et Informatica Journal*, 2013; 13(2): 18-31.
22. S.Sathish Kumar and C.Nagarajan, "Performance - Economic and Energy Loss analysis of 80 KWp Grid Connected Roof Top Transformer less Photovoltaic power Plant," *Circuits and Systems*, 2016; 7(6): 662-679.