

EFFECT OF NEUTRAL SYSTEMS ON TEMPORARY OVERVOLTAGE IN DISTRIBUTION NETWORKS

Gamal Hazza*

Associate Professor in the Electrical Engineering Department Faculty of Engineering, Albaha University, KSA.

Article Received on 28/05/2020

Article Revised on 18/06/2020

Article Accepted on 08/07/2020

*Corresponding Author

Gamal Hazza

Associate Professor in the
Electrical Engineering
Department Faculty of
Engineering, Albaha
University, KSA.

ABSTRACT

The effect of neutral systems for distribution networks has been evaluated when overvoltage caused by grounded faults. Sana'a distribution networks; as a part of Yemeni interconnected system; have been investigated as a case study. The obtained results confirmed that temporary overvoltage phenomena should be taken into account when neutral systems connect to the neutral point of transformers. Results

demonstrate that the installed neutral systems in the distribution networks need remediation in order to overcome the overvoltage phenomena, especially in the 15 kV level. In this work, some solutions have been suggested for mitigating overvoltage values during the faults. The suggested mitigation method based on a modification of the neutral system to add constraints for preventing the unacceptable temporary overvoltage limit which equals 1.2 pu of the nominal voltage value.

KEYWORDS: Distribution network, Neutral systems, Temporary overvoltage, power quality.

1. INTRODUCTION

There are several numbers of neutral methods used in distribution systems: Insulated earthing, resistance earthing, solid earthing, reactance earthing, and resonant (Peterson coil) earthing.^[1-8] These methods have important influence when faults to ground occur in the distribution systems. Criteria for selecting any type of neutralization are to secure the best compromise of the conflicting advantages and disadvantages of the various methods.^[1]

Neutral systems should meet several requirements during normal and abnormal network operations including voltage, grounded, ungrounded three-phase load, ...etc.^[2,3] Therefore, improper selection of neutral methods in the distribution system may lead to temporary system overvoltage that may damage the earthed connected electrical equipment. As a case study, the used neutral methods in the Yemeni distribution networks have been investigated. The interconnected system of Yemen consists of the transmission system which covers 132 kV networks and electrical distribution networks which cover 33 kV, 15 kV, 11 kV, and the low voltage (380/220 V) systems.^[9-10] In this paper, only the distribution networks which cover 33, 15, and 11 kV at Sana'a City (the capital of Yemen) have been taken under consideration in order to investigate the overvoltage that occurs during faults to ground.

2. Sana'a Distribution Networks Data

The neutral systems are similar in distribution networks of interconnected systems in most regions in Yemen as shown in Fig.1. The neutral system in Sana'a distribution networks is a solidly to ground in the 132 kV side. In the 33 kV sides of the network, transformers have delta connection and the network has been connected to earth through zigzag transformers. It is a 9 ohms resistance earthing in 11 kV side and insulated earthing in 15 kV side of the network.

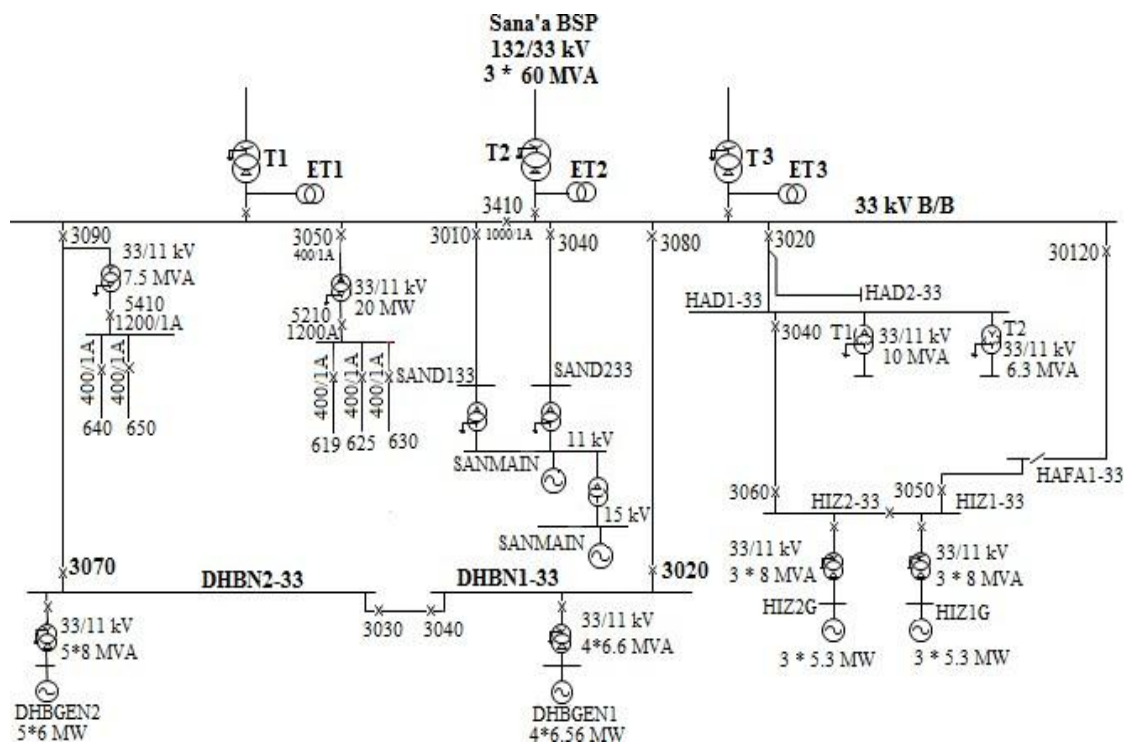

Fig. 1: 33/15/11 kV Sana'a Distribution Network (Case Study).

Tables 1,2: and 3 show the relevant technical system data for transformer, generators, and feeders respectively.

Table 1: Transformers Data.

Connection	Ratio kV	Rated MVA	Neutral Earthing Method		X %
			Primary side	Secondary side	
Ynd1	132/33	60	Solidly	Zigzag transformer	9.9
Ynd1	132/33	60	Solidly	Zigzag transformer	9.9
Ynd1	132/33	60	Solidly	Zigzag transformer	9.9
Dyn11	33/11	22	-	Resistance (9 Ω)	8.5
Dyn11	33/11	22	-	Resistance (9 Ω)	8.5
Yd11	11/15	6.3	Isolated	-	10
Ynd11	33/7.2	30	Solidly	-	15
Znyn11	33/0.4	0.4	solidly	Solidly	4.8

Table 2: Generators Data.

Generator Rated, MVA	Rated KV	Power factor	Neutral Earthing Method	X ₂ ,% Machine Base	X ₀ ,% Machine Base	X _d ,% Machine Base	X _d ,% Machine Base
6.56	11	0.8	Solidly	22.6	12	21	34
3.36	15	0.8	Solidly	22.6	12	21	34

Table 3: 33 kV Feeders Data.

OHL Feeders				Cable			
R ₊ , Ω /km	X ₊ , Ω /km	R ₀ , Ω /km	X ₀ Ω /km	R ₊ , Ω /km	X ₊ , Ω /km	R ₀ , Ω /km	X ₀ Ω /km
0.17	0.3153	0.287	1.273	0.064	0.116	0.2	0.29

3. METHODOLOGY

The system neutral methods are established practice but the problem is "what is methods are best suited to the application?". Generally, the basic factors that have to be evaluated for any given system are:

1. Sensitivity and selectivity of the ground relaying
2. Limitation of the magnitude of the ground fault currents.
3. The required degree of surge voltage protection with lightning arrestors.
4. Limitation of temporary overvoltage through system design.

One of the impacts of neutral systems that they have important influence due to occurring faults to ground in the distribution systems. Criteria for selecting any type of neutralization are to secure the best compromise of the conflicting advantages and disadvantages of the various methods.^[1,3,6] Improper selection of neutral methods in the distribution system may

lead to temporary system overvoltage that may damage the earthed connected electrical equipment. Therefore, the following major steps should be satisfied:

1. Comply with criteria to limit temporary overvoltage to less than 1.2 pu.
2. Allow enough currents to flow so that the ground fault relays will operate reliably.

4. RESULTS

The considered initial condition during the analysis is shown in Table 4 and the following considerations have been taken into account:

- 1) Single line to ground faults occur on phase A,
- 2) Line to line to ground faults occur on phases B and C,
- 3) System phase sequence ABC.

Phase difference has been considered with the assumption that the phase (a) is always with the reference axis. Phase (a) rotates to a reference point is just for simplification of the comparison purpose for the following network conditions:

- 1) When faults occur on 15kV Bus and the impact on the voltage level of 15 kV B/B.
- 2) When faults occur on 11 kV Bus and the impact on the voltage level of 11 kV B/B.
- 3) The voltage on 33 kV Bus bar due to fault on 33 kV BB.

The Power World simulator^[11] was used in the analysis and result shown in the mentioned figures below. Figures 2,3 and 4 show only the most severe conditions during faults to ground where the impact of the fault on voltage levels on the same B/B, where results show obviously overvoltage on the different levels of healthy phases.

Table 4: Initial condition of the network understudy.

BUS NAME	Pre-Flt					
		V _{LL} ,kV	deg		V _{ph} , kV	deg
ASSER132	AB	132	0	A	76.21	-30
	BC	132	-120	B	76.21	-150
	CA	132	120	C	76.21	90
ASSER33	AB	33	30	A	19.05	0
	BC	33	-90	B	19.05	-120
	CA	33	150	C	19.05	120
SANM33	AB	33	30	A	19.05	0
	BC	33	-90	B	19.05	-120
	CA	33	150	C	19.05	120
SANM11	AB	11	0	A	6.35	-30
	BC	11	-120	B	6.35	-150
	CA	11	120	C	6.35	90

SANM15	AB	15	30	A	8.66	0
	BC	15	-90	B	8.66	-120
	CA	15	150	C	8.66	120

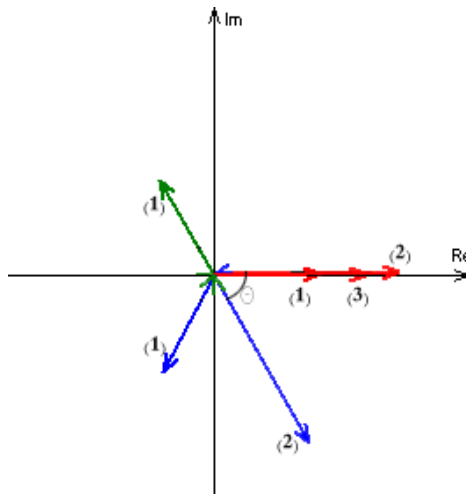

Fig. 2: Voltage of 15 kV Bus bar due to Faults on 15kV Bus.

1. Pre-Fault Voltage Phasors = 1 pu and $\Theta = -120^\circ$
2. LG Fault Voltage Phasors = 1.73 pu and $\Theta = -60^\circ$
3. LLG Fault Voltage Phasors= 1.5 pu

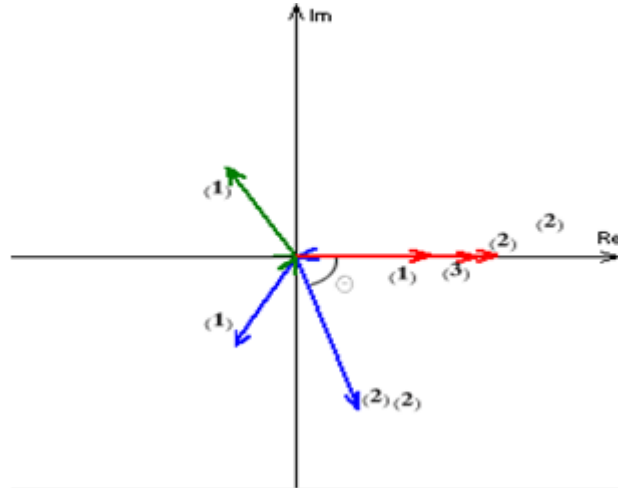

Fig.3 Voltage of 11 kV Bus bar due to Faults on 11 kV Bus.

- 1) Pre-Fault Voltage Phasors = 1 pu and $\Theta = -120^\circ$
- 2) LG Fault Voltage Phasors = 1.5 pu and $\Theta = -70^\circ$
- 3) LLG Fault Voltage Phasors = 1.4 pu

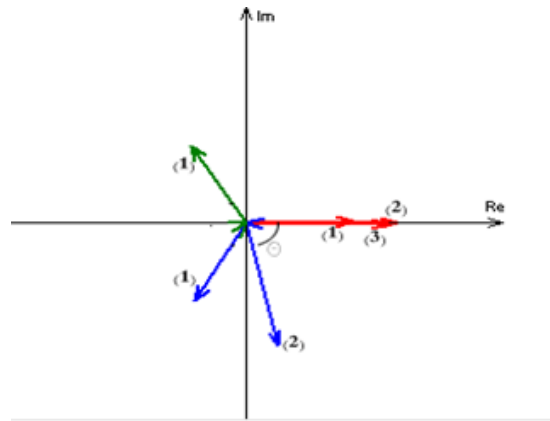

Fig. 4: Voltage on 33 kV Bus bar due to fault on 33 kV BB.

- 1) Pre-Fault Voltage Phasors = 1 pu and $\Theta = -120^\circ$
- 2) LG Fault Voltage Phasors = 1.4 pu and $\Theta = -80^\circ$
- 3) LLG Fault Voltage Phasors = 1.3 pu

5. Remediation

In this work and for 15 kV level changing the connection from Ynd11 to Dyn11 solidly grounded will mitigate the no faulty phases voltages during fault from 1.73 pu in the existing case to 1 pu. But this solution needs review for protection settings. Also, for 15 kV level, management schedule between Yemen utility diesel generators and industrial diesel sets in order to put in operation continuously to mitigate overvoltage during faults. Fig.5 shows the impact of the diesel generators on voltage levels where the voltage level dropped from 1.73 pu to 1.25 pu. In this case, there is no warred about increase of the short circuit levels because the generators normally put in operation during peak periods.

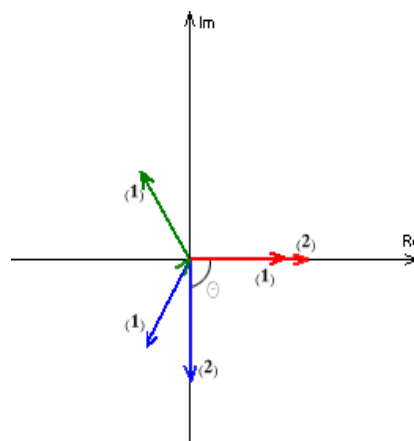

Fig. 5: Voltage of 15 kV Bus bar due to Faults on Gen.15kV Bus.

- 1) Pre-Fault Voltage Phasors = 1 pu and $\Theta = -120^\circ$
- 2) LG Fault Voltage Phasors = 1.25 pu and $\Theta = -90^\circ$

Wye-delta connection between 11 and 15 kV systems can be replaced by wye – wye grounded connections because the advantages of this system that are this system more economical than other connections. In this connection, fault contribution from 11 kV system to 15 kV will be avoided also.

Delta-wye grounded can be used in this part of the distribution network. The advantages of this type prevent third harmonics that can be created in the 15 kV when the synchronous generator put into the 11 kV system.

6. CONCLUSIONS

Results of this work show that improper selection of a neutral system may cause temporary overvoltage during faults to ground. Also, the results show that the neutral systems in distribution systems in electrical networks in Yemen (as case study) need a review in order to overcome the overvoltage occurs during faults especially in 15 kV level. For 33 and 11 kV levels, results show the need for further detailed study in order to obtain the suitable solutions for overcoming on the overvoltage phenomena during faults to ground. The reason is that the modification of transformer connections have an effect on different phenomena like harmonics, short circuit level etc. Some solutions have been suggested in this work for mitigation the temporary overvoltage by modifying the existing neutral methods in the network. Further work is needed for detailed analysis about the effect of the neutral system selection on another related power quality issues.

REFERENCES

1. C57.105-1978, IEEE guide for the application of transformer connections in three-phase distribution systems, 1978.
2. Arritt, R.F. Dugan, R.C.," Distributed generation interconnection transformer and grounding selection", Power and Energy Society General Meeting - Conversion and Delivery of Electrical Energy in the 21st Century, 2008 IEEE, 20-24 July, Pittsburgh, PA, 2008.
3. Rusch, R.J. Good, M.L," Wyes and wye nots of three-phase distribution transformer connections", Rural, 30 April-2 May, Stanley Consultants Inc., Muscatine, IA, USA, 1989.
4. Kunda, D., Neudorf, E.G., Perris, N., Szeto, L.M., Krause, D.V.," Electrical impact of a NUG under.
5. MW rating when connected to a distribution feeder with various transformer

- connections", Industrial and Commercial Power Systems Technical Conference, 1994. Conference Record, Papers Presented at the Annual Meeting, 1994 IEEE, 1-5 May 1994, Irvine, CA, 1994.
6. Sutherland, P.E. Short, T.A. "Power Quality Assessment of Distributed Generator Grounding Method", IEEE Transactions on Industry Applications, Volume: 45, Issue: 1, Jan.-Feb., On page(s), 2009; 303 – 309.
 7. Dr. Luke YU, Rolf L Henriks," Selection of System Neutral Grounding Resistor and Ground Fault Protection for Industrial Power Systems", Proceedings of Petroleum and Chemical Industry Conference, 9-11 Sep, 1991; 147-153.
 8. R. F. Arritt, R C Dugan, "Distributed Interconnection Transformer and Grounding Selection", Power and Energy Society General Meeting – Conversion and Delivery of Electrical Energy in the 21st Century, IEEE, 20-24 July 2008, Pittsburgh, PA, 2008.
 9. Gerald Dalke, "Unconventional Connections and How to Get it Right", Industry Applications Conference, 2003, 38th IAS Annual Meeting, 12-16 Oct, Proceedings: vol 2, pp 1292-1297, Basler Electric., Edmond, OK, USA, 2003.
 10. Gamal Abdul Wareth Hazza, "Voltage Drop Problem in Sana'a Distribution Network", Journal of Faculty of Engineering, Sana'a University, Vol. 1, No.1, pp 40-55, July (in Arabic), 2003.
 11. Omer M Awed Badeeb, Gamal A W Hazza "Application of the Slow Coherency Decomposition Method on the Yemeni Network", International Journal of Electrical Engineering and Electronics(IJEEE), UMIST, Manchester, UK, 2004; 41(1): 56-63, <https://doi.org/10.7227/ijeee.41.1.5>.
 12. www.powerworld.com, web site of Power World Corporation.



AUTHOR PROFILE

Gamal A.W. Hazza is born in 1959. He holds BSc in electrical engineering from Aleppo University, Syria, in 1982, MSc in electric power systems from Cairo University, Egypt, in 1991 and PhD in electrical engineering and electronics, from UMIST /Manchester, Britain, in 1999. He has promoted Associate Professor degree in 2004 from the University of Sana'a, Yemen. He was a participant in the training courses in the field of accreditation and quality

assurance in 2008 at the Centre for Higher Education Policy Studies (cheps), University of Twente, Enschede, the Netherlands. Currently, he is working in Saudi Arabia with Albaha University, College of Engineering, in the Department of Electrical Engineering.