

SIGNSPEAK: SOLAR POWERED MULTIPURPOSE AUTONOMOUS AGRICULTURAL ROBOT

Nisarga M. P.¹, Gowthami D. N.*², Ananya J. R.³, Keerthana H. B.⁴, Sudarshan G.K.⁵,
Nithin K.⁶

*^{1,2,3,4}Department of Information Science & Engineering, Malnad College of Engineering
Hassan.

Article Received on 14/03/2024

Article Revised on 03/04/2024

Article Accepted on 24/04/2024



*Corresponding Author

Gowthami D. N.

Department of Information
Science & Engineering,
Malnad College of
Engineering
Hassan.

ABSTRACT

In India almost around 70 level of individuals are depending in the wake of developing. Various tasks are acted in the developing field like seed planting, wrinkling, and so on. The continuous procedures for seed planting wrinkling. The stuff's utilized for above practices are costly and wrong to make due. So the developing construction in India ought to be locked in by empowering a framework which will reduce the work supply and time. This work means to arrangement, make and arrangement of the robot which can lay out the planting, sensors and grass cutting, this entire design is compelled by light based energy.

The organized robot gets energy from sun energized charger and is worked utilizing Bluetooth/Android Application which gives the messages to the robot for required parts and improvement of the robot. This expands the ability of seed planting furthermore diminishes the issue experienced in manual planting. It besides gives manual control when required and watches the clamminess with the assistance of constancy sensors. The main part here is the At Arduino UNO microcontroller that manages the whole cycle. On the field the robot works the field is completely worked in manual mode. For manual control the robot involves the Bluetooth matching application as control gadget and helps throughout the robot outside the field. The vital thought process in making horticultural automation mechanical advancement is diminishing work force, a sensation normal in ordinarily the creating scene. Regularly, the reasons are the reliance on further develop food varieties quality.

KEYWORDS: Soil Moisture level, Iot Server, Telnet.

I. INTRODUCTION

The fundamental thinking in making Developing Robotization Improvement is reducing workforce, a characteristic common in the creating circumstance. The reasons are the need for extra cultivate food quality. Significant level mechanics and robotized thinking accomplishments offer game- plan in precision agribusiness to manage related with creating, acquiring, weed control, forest the chiefs, compound applications, and so forth to encourage capability and effectiveness furthermore. The use of instrumental undeniable level mechanics are spreading each chance to cover further spaces, as the chance dislodging human heads outfits reasonable blueprints with benefit from experience. Numerous commonplace robots have been researched and made to finish different developing things in different nations. Ranchers today consume massive proportion of cash on machines that assist them with reducing work and expansion yield of harvests. There are different machines that are open for pick and setting, gathering, sprinkling water, and so on, but these machines ought to be genuinely endeavored to play out the ordinary endeavors and moreover separate machines are utilized for each limit. The return and benefit get back from utilizing this stuff are exceptionally less when showed up distinctively corresponding to the speculation. One more issue is the making requesting of the outright individuals. The World Success Connection makes sure that World's overall public will contact 9 billion of as expected which will incite a stunning interest what's more of progress of food crops. Robotization is the most suitable reaction for vanquish every one of the as of late referred to lacks by making machines that perform more than one activity and mechanizing those tasks to increase yield for an immense degree.

II. LITERATURE SURVEY

Agribusiness' set of experiences goes back millennia, and its improvement was driven and characterized by totally different environments, societies and advancements. Thus, the horticulture framework ought to be progressed to lessen the endeavors of the ranchers. The advantages of robot are decreased human mediation and productive assets usage. Guidelines are passed to the framework utilizing bluetooth which guarantees no immediate contact with human and accordingly wellbeing of administrator is guaranteed. The robot is sunlight based fueled thus it is sustainable power source. The bluetooth/android application which is utilized to control the robot is as displayed in Fig.10. It comprises of 12 keys. Examine key are utilized for matching of application with HC-05 module and set keys is utilized to add further keys whenever required. The stop, right, left, forward and in reverse keys are utilized to control the developments of the robot. The leftover keys like grass, shower, see dare used to

actuate the instruments. All OFF key is useful in deactivating the systems and it will stop the development of robot.^[1]

The paper^[2] robot will perform cultivating the field in enormous areas of land without including the human in the base measure of time. The robot can identify and furthermore keep away from the impediments effectively without modifying the fundamental framework. Along these lines, robots can play out the errands like moving, keeping away from deterrents, checking, cultivating the field, and so forth.. With the development of robot cultivating network, food manufacture can be expanded significantly and economically.^[2] Mobile automated item for organic product trimming was represented on this paper. The development of the method started to trim date palm natural products which is the best incessant natural product all through Saudi Arabia. Normally the framework was essentially founded on readymade proficient mechanical arm. Commonly the creators are glad to Lord Abdulaziz City for Logical disciplines and Innovation (KACST) for subsidizing normally the undertaking MT-1-3. utilizing Arduino Uno, Engine Driver L293D, HC05-Remote Bluetooth module likewise to get the objective with respect to this venture, to acquire data about Ultrasonic sensor HCSR-04, reconcilable programming and dealt with engine circuit need to be recognized. The number with respect to different elements in regards to this robot is generally to show the distance through the hindrance on the specific portable application consistently. More altered client accommodating simple dealing with Agri-bot can be taken care of just by remote rather contrasted with the application. stores and converts the sun oriented energy into electrical energy which is given to charging circuit to charge the battery to 12 V which will provide the important capacity to regulator, DC engine and various components. The planned multipurpose machine is utilized as water sprayer, which lessens the labor supply and uses sun based power. The robot can be worked with voice orders. A robotized electric vehicle with battery worked with sunlight based power highlights are planned and created to work on the existence of battery, grass cutting and water spraying .Agriculture uses 85% of available freshwater resources worldwide, and this percentage will continue to be dominant in water consumption because of population growth and increased food demand. There are many systems to achieve water savings in various crops, from basic ones to more technologically advanced ones. The automated irrigation system implemented was found to be feasible and cost effective for optimizing water resources for agricultural production.^[3]

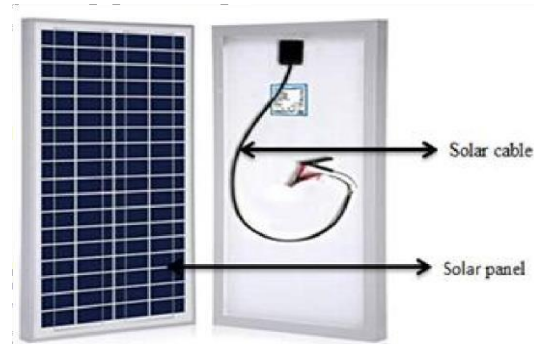

Some kind of vision-based line guidance technique is shown to direct robot stage which will be planned free of one another to drive by the column vegetation in an industry in light of the plan thought of open design. And afterward, the offset as well as heading point in the robot stage as a rule are distinguished in certifiable chance to drive the stage upon the premise related with acknowledgment of the yield column utilizing machine vision. Notwithstanding the control design of the framework is proposed to complete line direction. At last, the specific primer trials related with line direction had been carried out in the vegetable field. New outcomes show that will calculations of line distinguishing proof and line direction are fruitful in view of the boundaries scored and broke down like the heading point notwithstanding the offset seeing column direction as well as the contrast between the specific movement direction related with the robot notwithstanding the normal flight. Furthermore, the dependability of column guidance is about $\pm 35\text{mm}$, which frequently infers that the robot might move having a sufficiently high exactness.^[4]

Some sort of vision-based row instruction method is displayed to guide robot platform which will be designed independent of each other to drive by the row plant life in an industry based on the design idea of open architecture. And then, the offset in addition to heading angle in the robot platform usually are detected in genuine time to drive the platform upon the basis associated with recognition of the crop row making use of machine vision. Mobile robotic product for fruit cropping was illustrated on this paper. The build up of the technique originated to crop date palm fruits which is the best frequent fruit throughout Saudi Arabia. Typically the system was primarily based on readymade professional robotic arm. Typically the authors are happy to King Abdulaziz City for Scientific disciplines and Technology (KACST) for funding typically the project MT-1-3. utilizes 85% of accessible freshwater resources around the world, and this rate will keep on being prevailing in water utilization due to populace development also, expanded food interest. There is a pressing need to make techniques in light of science and innovation for manageable utilization of water, including

specialized, agronomic, administrative, and institutional enhancements.^[5]

The course of seed planting is a critical part of the farming field. For the vast majority crop assortments, high-accuracy pneumatic establishing has been created for an extensive variety of seed sizes, bringing about uniform seed dissemination in seed dividing along the movement way. Wi-fi is utilized as a collector. Principal drawback of the framework is that the robot moves in just a single bearing. There are numerous frameworks to accomplish water reserve funds in different crops, from essential ones to additional mechanically progressed ones. For example, in one framework plant water status was checked also, water system planned in light of covering temperature distribution of the plant, which was gained with warm imaging. Moreover, different frameworks have been created to plan water system of yields and enhance water use through a harvest water pressure list (CWSI). The exact CWSI was first characterized quite a long time back. At the point when there is an obstruction the power supply is consequently turned off. This machine's working mode is straightforward. It is feasible to actually build the complete yield rate. Work issue can be diminished. When contrasted with the manual and work vehicle based planting investment expected for this robot machine is less. Additionally wastage of seed is less. The disservice of model is, it comprises of just a single component.^[6]

In ecological applications, sensor networks have been used to screen different natural boundaries or conditions in marine, soil, and environmental settings. Arduino uno has everything expected to help the specific microcontroller; essentially connect it to some PC with a USB link or interface it with an air conditioner to-DC connector or even battery to begin. Ecological boundaries, including dampness, pressure, temperature, soil water content, and radiation with various spatial furthermore, worldly goal and for occasion recognition like calamity observing, contamination conditions, floods, woods fire, and flotsam and jetsam stream is ceaselessly checked. Applications in horticulture have been utilized to give information to proper the board, for example, checking of ecological conditions like climate, soil dampness content, soil temperature, soil ripeness, mineral substance, and weed illness location, observing leaf temperature, dampness content, and checking development of the yield, mechanized water system office and capacity of farming items. Different business WSNs exist, going from restricted and low-goal gadgets with sensors and implanted processors to finish and costly obtaining frameworks that support different sensors and incorporate a few correspondence highlights. Late advances in microelectronics and remote

advancements made minimal expense and low-power parts, which are significant issues particularly for such frameworks such as WSN. Power the board has been tended to in both equipment and programming with new electronic plans also, activity strategies. The choice of a chip becomes significant in power mindful plan.

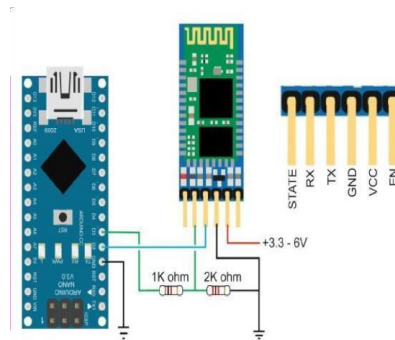

The main aim of this paper is a development of solar powered multipurpose agricultural robot that which operated by infra-red remote control. This robot can Plow the soil, feeds the seed, cuts the grass and spray the water for crops in the agricultural field. As we already know that solar energy is a renewable resource of energy, it is freely available in nature. So that going to utilize this energy for agricultural purpose. By using this robot technology, the farmer can save lot of money and time. In this project the solar power first converted into electrical power using solar panel then this power will be saved in a rechargeable battery. This saved electrical power will be used for powering the robot. This robot made up of the main components as microcontroller, motor driver, gear motors, water pump, grass cutter, lead acid battery and solar panel.^[8]

III. RESEARCH GAPS

Our comprehensive survey of existing research illuminates critical lacunae within the domain of Indian Agriculture. Although widely used, Agriculture suffers from a lot of problems dedicated research research on Solar powered multipurpose agriculture robot uncovers a few basic holes that need addressing to streamline their usefulness and effect on cultivating rehearses. First and foremost, upgrading sunlight powered charger proficiency is basic to amplify energy gathering and guarantee supported activity in shifting natural circumstances. Going with this, progressions in energy capacity arrangements are important to alleviate energy deficiencies during low-light periods, empowering continuous activity Coordination of cutting edge sensors is critical for ongoing observing and navigation, requiring investigation into sensor advancements versatile to horticultural conditions. Climate

flexibility and toughness are basic viewpoints requiring investigation into planning SPMARs fit for enduring unforgiving circumstances and requiring negligible upkeep. Guaranteeing interoperability among various SPMARs and ranch the board frameworks is fundamental for consistent incorporation and productive information trade. Instructive drives are expected to work with the reception of SPMAR innovation among ranchers, while policymakers should address administrative systems to help its arrangement and use. Social acknowledgment studies are fundamental for measure ranchers' insights and encourage local area commitment. At last, long haul supportability appraisals are basic to guarantee SPMARs' environmental and financial suitability. Crossing over these examination holes is fundamental for understanding the maximum capacity of SPMARs in upsetting current cultivating rehearses and tending to worldwide farming difficulties.

Our research endeavors are strategically designed to address these prevalent gaps, paving the way for the development of robust and effective robot. Our efforts aim to contribute significantly to bridging the multipurpose robot for farmers working in Agriculture field.

CHALLENGES

Sun oriented fueled multipurpose farming robots face various difficulties that upset their inescapable reception and viability. First and foremost, upgrading sun powered charger proficiency and energy stockpiling capacities stays a key obstruction, affecting the robot's capacity to work persistently in differing light circumstances. Furthermore, guaranteeing hearty versatility and independent route in different territories presents critical specialized difficulties. Incorporating progressed sensors for ongoing observing and direction requires conquering innovative restrictions and guaranteeing dependability. Accuracy horticulture undertakings, for example, crop acknowledgment and designated medicines request refined calculations and precise sensor information. Besides, addressing cost-adequacy and versatility issues is vital to make these robots open to limited scope ranchers. Climate strength and sturdiness are likewise basic contemplations, as robots should endure brutal natural circumstances while keeping up with execution. At last, accomplishing interoperability among various robots and homestead the executives frameworks is fundamental for consistent reconciliation and information trade, featuring the complex difficulties confronting sunlight based controlled multipurpose agrarian loot.

RESULT

The specific cultivating utilizing this particular gadget is alluded to as accuracy cultivating.

The specific primary parts with respect to the robot normally are the turner, plougher and the tires segment. cameras can be found for imploring and nitrogen-loaded grass shaper machine. The turner is generally a level club with a measure of rugged teeth's put on it together to circulate air through or discharge the dirt.4 dc engines generally are mounted on wheels put on one or the other perspective such that every viewpoint is driven just by two engines every single This way industry is furrowed notwithstanding cultivated.As indicated by fundamental discoveries from this review, the vast majority of these independent frameworks are more adaptable than customary frameworks. The upsides of lower work expenses and restricting the quantity of everyday working hours essentially gotten to the next level. Subsequently, has empowered the mechanization of the main working schedules Some, in any case, have flopped because of the necessity for accuracy in unambiguous undertakings moreover, at this phase of the turn of events, starting speculation, and yearly expenses of a costly GPS framework are as yet continuous, generally high, yet it seems practical to plan financially suitable grass mechanical frameworks cutting, crop cultivating, and selfweeding The discoveries show that there is a critical .On the off chance that sufficient control and security can be forced, these frameworks can possibly be utilized.

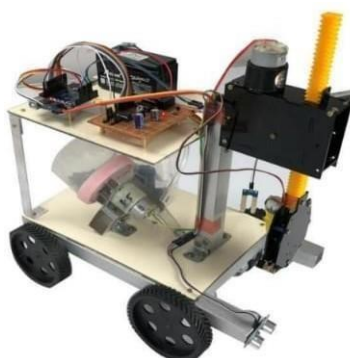

Table I: Some Commonly Used Equipments For Evaluation Of The Data Collected By The Agricultural Field.

Reference	Data Collection	Equipment	Recognition Accuracy
[1]	Plants surrounding land in a agricultural field	Soil moisture sensor	Soil moisture-20% Land is dry Soil moisture-80% Land is wet
[2]	Land in agricultural field	Fire sensor	Possibility-yes Possibility-no
[3]	Agriculture Field	Humidity sensor	Temp-low Temp-high
[4]	Agriculture Fiels	Air condition predictor sensor	Air condition-not polluted Air condition -polluted
[5]	Agriculture Field	seeding	Done

FUTURE SCOPE

As per starter discoveries from this review, the majority of these independent frameworks are more adaptable than customary frameworks. The upsides of lower work expenses and restricting the quantity of everyday working hours essentially moved along. Subsequently, has empowered the robotization of the main working schedules. Some, nonetheless, have bombed because of the prerequisite for accuracy in unambiguous undertakings. Moreover, at this phase of the turn of events, starting venture, and yearly expenses of a costly GPS framework are as yet progressing, generally high, however it seems possible to plan financially suitable grass mechanical frameworks cutting, crop cultivating, and selfweeding. The discoveries demonstrate that there is a huge .On the off chance that satisfactory control and wellbeing can be forced, these frameworks can possibly be utilized.

CONCLUSION

All in all, the improvement of a sunlight based controlled multi-reason horticultural robot able to do at the same time really looking at dampness, fire discovery, soil dampness, and cool addresses a huge progression in present day cultivating innovation. This coordinated arrangement offers ranchers an extensive device for checking key ecological boundaries basic to edit wellbeing and yield streamlining. By saddling inexhaustible sun oriented energy, this robot guarantees feasible activity while decreasing dependence on customary energy sources. Its capacity to play out numerous errands proficiently smoothes out rural tasks, saving time and work costs. Additionally, the ongoing information given by the robot empowers ranchers to settle on informed choices and answer expeditiously to changing ecological circumstances, eventually upgrading by and large homestead efficiency and strength. As we keep on developing in farming mechanical technology, the reconciliation of such flexible and independent frameworks holds extraordinary commitment for tending to the difficulties of current horticulture and guaranteeing food security in a quickly impacting world.

REFERENCES

1. Nayyar, Anand and Er Vikram puri “IoT Based Smart Sensors Agriculture Stick for Live Temperature and Moisture Monitoring using Arduino cloud computing & Solar Technology.” International conference on Communication and Computing Systems (ICCCS-2016), 2016.
2. Internet-Of-things (IOT) Based Agricultural Robot Toushia Parveez¹, Wafa Maheen Sherrief², Prakruthi J³, Ramya M B⁴, Sahana MS⁵.

3. Suma v, "Internet-Of-Things (IOT) based smart Agriculture in India-An Overview." Journal of ISMAC, 2021; 3.01: 1-15.
4. Narasimman, Dr Suresh, Et A1. "IOT Based Smart Agriculture and Automatic Seed Sowing Robot." Journal of Engineering Sciences, 2022; 13.7.
5. Gowrishankar, v., and K. Venkatachalam. "IOT based Precision agriculter using Agribot." Global Research and Development Journal for Engineering, 2018; 3.5: 2455-5703.
6. Doshi, Jash, Tirthkumar Patel, and santosh Kumar Bharti. "Smart Farming Using IOT, a Solution for optimally monitoring farming conditions." Procedia Computer Science, 2019; 160: 746-751.
7. Stoces, Michal, et al. "Internet of things (iot) in agriculter-selected aspects." Agris on-line papers in Economics and Informatics, 2016; 8.665-2016-45107: 83-88.
8. Mohanraj, I., Kirthika Ashokumar, and J..Naren. "Field monitoring and automation using IOT in agriculture domain." Procedia Computer Science, 2016; 93: 931-939.