

POWER TURBINES CONTROL, PART IV: STEAM TURBINE SPEED CONTROL USING 2/2 SECOND-ORDER, I-PD COMPENSATORS AND PD-PI, 2DOF-3 CONTROLLERS COMPARED WITH A PI CONTROLLER

Galal Ali Hassaan*

Emeritus Professor, Department of Mechanical Design and Production, Faculty of Engineering, Cairo University, EGYPT.

Article Received on 08/07/2024

Article Revised on 28/07/2024

Article Accepted on 18/08/2024



*Corresponding Author

Galal Ali Hassaan

Emeritus Professor,
Department of Mechanical
Design and Production,
Faculty of Engineering,
Cairo University, EGYPT.

ABSTRACT

This paper is the fourth in a series of research papers presenting the control of power turbines using compensators and controllers from the second generation of compensators and PID controllers. It handles the control of a steam turbine load speed using 2/2 second order compensator, I-PD compensator, PD-PI controller and, 2DOF-3 compensator with comparison with the use of a PI controller from the first generation of PID controllers. The MATLAB optimization toolbox is used to tune the four compensators/controllers using an ITAE performance index. The step time response of the control system

using the four proposed controllers is presented and compared with using a PI controller to control the same steam turbine and the time-based characteristics are compared. The comparison reveals the best compensator/controller among the four compensators/controllers depending on a quantitative comparison study.

KEYWORDS: Power turbines control, steam turbine speed control, 2/2 second order compensator, I-PD compensator, PD-PI controller, 2DOF-3 controller, PI controller, controllers tuning.

INTRODUCTION

Taqi ad-din Mohammed ibn Ma'rif of Ottoman Egypt described in 1551 a steam driven wheel in his book '*The sublime methods of spiritual machines*' and some of its practical applications.^[1] This invention was before the Italian Giovanni Branca in 1629 and the British John Wilkins in 1648.^[2] The first use of steam turbines in electricity generation started in 1884 by the British Engineer Charles Parsons who developed a steam turbine connected to a dynamo producing 7.5 kW of electric power.^[3]

Hammid (2013) used a block diagram for a steam turbine frequency control and applied the conventional controllers: P, I, PI, PD and PID to control the steam turbine-generator unit. He tuned the used controllers using the Ziegler-Nichols method and applied MATLAB/simulink for the step time response of the control system.^[4] Dulau and Bica (2014) presented the mathematical modeling of a steam turbine unit. They found the step time response of the turbine torque and speed using MATLAB/simulink for a proportional controller for uncertain parameters for the controlled process and different loads.^[5] Rosyadi et al. (2015) presented simplified models for the simulation of wind turbine generator, steam turbine generator, and hydro turbine generator units. They provided typical values for turbines parameters and presented the time response of the terminal voltage, active reactive power and rotor speed. They concluded that the simplified models had sufficient accuracy in both steady-state and transient conditions.^[6] Ozcelic and Celep (2016) proposed the design of model based adaptive PID controller with parallel feedforward compensator to steam turbine speed control. They presented linear models for the steam turbine sections, nominal and range of the plant parameters and a 2/5 nominal plant transfer function and the unit step time response of the uncontrolled system. The step time response of the steam turbine speed using the PID controller was not shown.^[7]

Dettori, Iannino and Signorini (2017) modeled a concentrated solar power plant with performance analysis for the power control loop. They proposed a hybrid fuzzy PID to improve the steam turbine generator performance compared to the conventional PID controller using three different tuning approaches. They presented the time response of the steam turbine power using a PI controller tuned by fuzzy logic and other methods.^[8] Reitinger, Cech and Konigsmarkova (2018) developed a real time simulator using mathematical-physical modeling. Their work focused on exact feedback controller design where they linearized the steam turbine model for operation in island and national grid

modes. They applied the generalized robustness regions method to design 2DOF controller for both working modes.^[9] Feyo, Thelkar, Bharatiraja and Abdayo (2020) presented the mathematical modeling of a steam turbine unit with a fuzzy controller in an isolated operating condition and displayed a simulink model of the steam turbine with fuzzy controller. They demonstrated an improved set point tracking control for turbine speed considering and neglecting governor dead-band. They derived $\frac{1}{2}$ transfer function model between the mechanical power and valve position changes and $\frac{1}{5}$ transfer function between the mechanical power and reference speed. They compared the application of model reference adaptive control and fuzzy control to control the steam turbine speed.^[10]

Abdul-Majeed (2021) evaluated the feasibility of using particle swarm optimization for optimal PID controller design for steam turbine speed control. He stated that this method of PID control tuning was more efficient in reducing the rise time, settling time and maximum overshoot. He achieved a maximum overshoot of 3.45 % with PID controller tuned by the proposed optimization technique.^[11] Nath, Tanni, Surja and Iqbal (2022) developed an improved control methodology for load frequency control for two types of steam turbines, reheat and non-reheat types. They proposed and simulated the use of PID, ANN and Fuzzy techniques for single area power system. They developed PID and fuzzy-logic controllers for a two-area power system.^[12] Gopi et al. (2024) introduced a methodology for enhancing the performance of load frequency control in power systems by employing rat swarm optimization for tuning and detecting the porpoising (control system oscillatory behavior) to ensure stability. The proposed PID controller tuning was compared with other methods such as firefly algorithm and Ziegler-Nichols techniques. They presented transfer function models between mechanical power and speed changes of the generator and compared the step time response of the speed control system using their proposed controller, Ziegler-Nichols and firefly algorithm controller.^[13]

Controlled Steam Turbine Speed

Dulau and Bica studied the simulation of reheat steam turbine through simple transfer functions for the steam turbine and the load. They used a $\frac{1}{2}$ transfer function for the turbine, $G_T(s)$ given by.^[5]

$$G_T(s) = (2.1s+1) / [(0.3s + 1)(7s + 1)] \quad (1)$$

They used a $0/1$ transfer function for a damped load, $G_L(s)$ given by:^[5]

$$G_L(s) = 1 / (10s + 1) \quad (2)$$

The transfer function for the steam turbine speed control, $G_p(s)$ is derived using Eqs.1 and 2 in cascade. That is:

$$G_p(s) = (2.1s + 1) / (21s^3 + 75.1s^2 + 17.3s + 1) \quad (3)$$

The unit step time response of steam turbine load unit having the dynamics defined by Eq.3 is shown in Fig.1 as generated by the 'step' command of MATLAB.^[14]

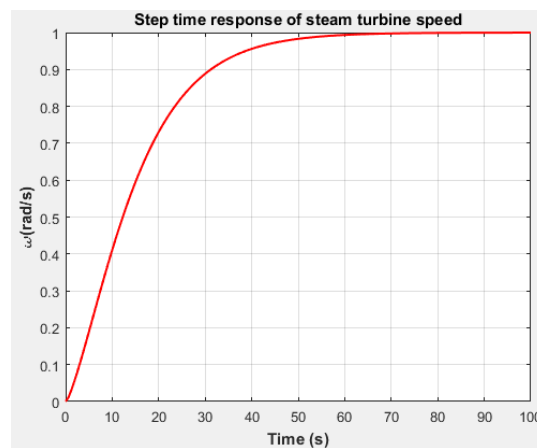

Figure 1: Step time response of the steam turbine load speed.

Comments

- ✚ The steam turbine load speed process is stable.
- ✚ It has a zero steady-state error.
- ✚ It has zero maximum percentage overshoot and zero minimum undershoot.
- ✚ It has a settling time of 48.28 s.

Controlling the Steam Turbine Load Speed Using a 2/2 Second-order Compensator

The 2/2 second-order compensator controller was introduced by the author to control a number of difficult processes since 2014 including: very slow second-order process^[15], highly oscillating second-order process^[16], greenhouse temperature control^[17] and boiler steam pressure.^[18] The 2/2 compensator is composed of two poles and two zeros transfer functions having the form:

$$G_c(s) = K(s + z_1)(s + z_2) / (s^2 + 2\zeta\omega_n s + \omega_n^2) \quad (4)$$

Where: K = compensator gain.

z_1, z_2 = two zeros of the compensator nominator.

ω_n = natural frequency of the compensator denominator.

ζ = damping ratio of the compensator denominator.

- The 2/2 compensator has five parameters (K, z_1, z_2, ω_n and ζ) to be tuned to satisfy the objectives of using the compensator to control the steam turbine load speed and provide good control system performance for reference and disturbance inputs.
- As an alternative to the above procedure, the values of the zeros are assigned in a way to get rid of the bad poles of the steam turbine-load unit (the ones near the origin of the s-plane. This directs us to the evaluation of the poles of the process transfer function of Eq.3. They are evaluated using the command 'roots' of MATLAB ^[19] and given by: -0.1, -0.1428 and -3.3333.
- To control the steam turbine load unit speed for reference input tracking, the transfer function of the closed loop control system is derived using the block diagram and Eqs.3 and 4. The two zeros of the 2/2 compensator are set equal to the two small poles of the turbine load unit. That is:

$$z_1 = 0.1 \text{ and } z_2 = 0.1428 \quad (5)$$

- The transfer function of the closed-loop control system using Eqs.3, 4 and 5 for reference input tracking becomes:

$$M_R(s) = (21Ks + K) / (s^3 + a_1s^2 + a_2s + a_3) \quad (6)$$

Where: $a_1 = 3.3333 + 2\zeta\omega_n$

$$a_2 = 21K + \omega_n^2 + 6.66666 \zeta\omega_n \quad (7)$$

and $a_3 = 3.33333 \omega_n^2 + K$

- The transfer function in Eq.6 reveals the fact that this control system will produce step time response for reference input tracking having a steady-state error. This steady-state error can be controlled by the value of the compensator gain. For a steady-state error of 0.001 for a unit step reference input, the gain K is related to the natural frequency ω_n of the compensator through the relationship:

$$K = 3330\omega_n^2 \quad (8)$$

- Now, the tuning procedure will be reduced to the evaluation of the optimal natural frequency ω_n and damping ratio ζ of the compensator while the other compensator parameters will be given by Eqs.5 and 8.
- The tuned parameters of the 2/2 compensator using an ITAE performance index ^[19] and the MATLAB optimization toolbox ^[20] are as follows:

$$\omega_n = 5.0306 \text{ rad/s}, \quad \zeta = 206.516 \quad (9)$$
- Using the closed-loop transfer function of the closed-loop control system for reference and disturbance inputs using the controller parameters in Eqs.5 and 9, the unit step time response is shown in Fig.2.

COMMENTS

- The 2/2 second-order compensator provided a reference input tracking step time response having the following characteristics:
 - ✚ Maximum percentage overshoot: 1.834 %
 - ✚ Settling time: 2.75ms
- The success of the 2/2 second-order compensator to reject the disturbance input is measured by the following characteristics:
 - ✚ Maximum mold temperature step time response: 1.549×10^{-14} rad/s
 - ✚ Minimum mold temperature step time response: zero
 - ✚ Settling time to zero (approximate): 0.5 s

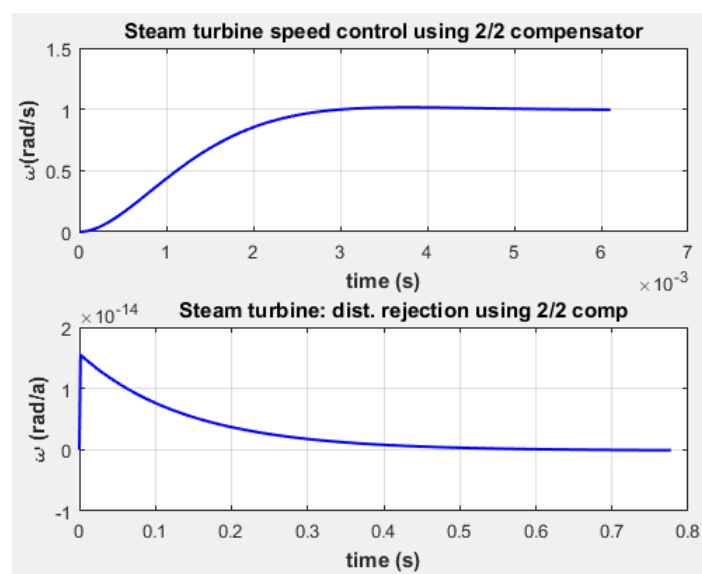

Figure 2: Step time response of the steam turbine load speed control using 2/2 second-order compensator.

Controlling the Steam Turbine Load Speed Using an I-PD Compensator

The I-PD compensator was introduced by the author to control a number of difficult processes since 2014 including: second-order-like processes^[21], greenhouse temperature^[17], boiler steam pressure^[18], rocket pitch angle^[22] and rolling strip thickness.^[23] The I-PD compensator is composed of two elements: an integral control mode element in the forward path just after the summing point of a single-loop control block diagram and a PD control mode element in the feedback path as illustrated in Fig.3.^[21]

- The closed-loop transfer function of the control system of the steam turbine load speed control for reference input tracking is obtained from the block diagram in Fig.3 and the process transfer function in Eq.3.
- This compensator will provide step time response with a specific steady-state error depending on the values of gain parameters (K_i , K_{pc} and K_d) of the compensator.

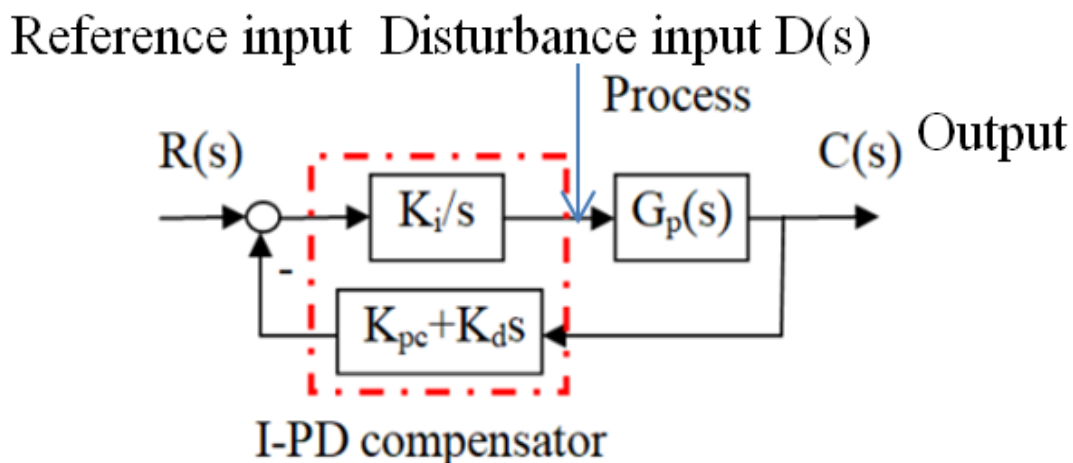

Figure 3: Steam turbine control using an I-PD compensator.^[21]

- The element $s+(K_{pc}/K_d)$ appears in the derivation of the transfer function for reference input tracking. It was set equal to the minimum pole of the controlled process ($s+0.1$) to simplify the transfer function equation and get rid of the critical pole of the controlled process. This step reveals:

$$K_{pc} = 0.1 K_d \quad (10)$$

- Investigating the closed loop transfer function for reference input tracking we get the following condition for zero steady-state error:

$$K_d = 10 \quad (11)$$

- This assigns the proportional gain of the I-PD compensator using Eq.10 as:

$$K_{pc} = 1 \quad (12)+$$

- Now, we are left with the integral gain K_i which has to be tuned using the MATLAB optimization toolbox^[20] for an ITAE performance index.^[19] The result is:

$$K_i = 0.220 \quad (13)$$

- The unit step time response of the control system with the I-PD compensator is obtained for both reference and disturbance inputs using the transfer functions derived from the block diagram in Fig.3 using the MATLAB command 'step'^[14] and shown in Fig.4.

COMMENTS

- The I-PD compensator provided a reference input tracking step time response having the following characteristics:
 - ✚ Maximum percentage overshoot: zero
 - ✚ Settling time: 32.72s
- The success of the I-PD compensator to reject the disturbance input is measured by the following characteristics (with second-order high pass filter):
 - ✚ Maximum mold temperature step time response: 1.552×10^{-14} rad/s
 - ✚ Minimum mold temperature step time response: -0.08×10^{-14} rad/s
 - ✚ Settling time to zero (approximate): 20s

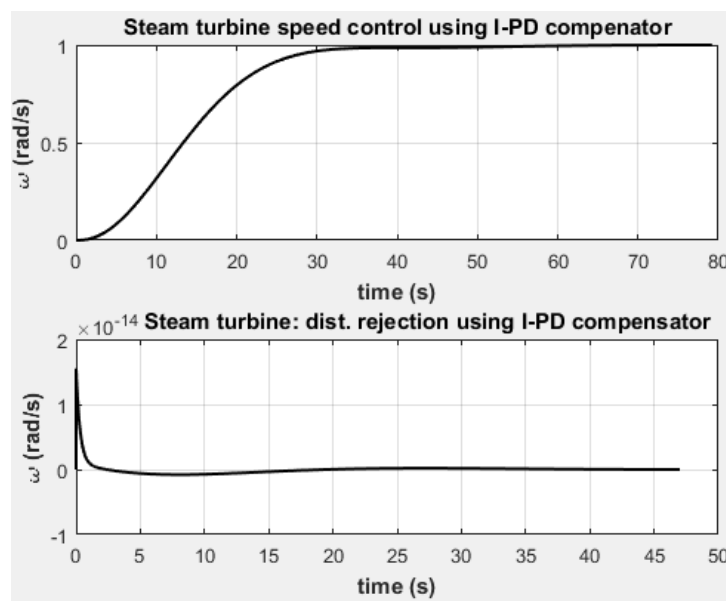

Figure 4: Step time response of the steam turbine load speed control using an I-PD compensator.

Controlling the Steam Turbine Load Speed Using a PD-PI Controller

The PD-PI controller was introduced by the author to control a number of difficult processes since 2014 including: its use in controlling first-order delayed processes^[24], highly oscillating second-order process^[25], integrating plus time-delay process^[26], delayed double integrating process^[27], third-order process^[28], boost-glide rocket engine^[29], rocket pitch angle^[22], LNG tank pressure^[30], boiler temperature^[31] boiler-drum water level^[32], greenhouse internal humidity^[33], coupled dual liquid tanks^[34], BLDC motor^[35], furnace temperature^[36], electro-hydraulic drive^[37] and rolling strip thickness^[38], IMM mold temperature^[39], IMM barrel temperature^[40], IMM cavity gate pressure^[41], IMM mold packing pressure^[42], IMM ram velocity^[43], IMM full-electric^[44], Al-Jazari turbine^[45], Banu Musa axial turbine power^[46] and wind turbine speed.^[47] PD-PI controller is composed of two elements: PD-control mode, $G_{c1}(s)$ in cascade with a second PI-control mode, $G_{c2}(s)$ just after the error detector.

The two elements have transfer functions given by:

$$G_{c1}(s) = K_{pc1} + K_d s$$

$$\text{and } G_{c2}(s) = K_{pc2} + K_i/s \quad (14)$$

Where: K_{pc1} = proportional gain of the PD-control mode.

K_d = derivative gain of the PD-control mode.

K_{pc2} = proportional gain of the PI-control mode.

K_i = integral gain of the PI-control mode.

- The PD-PI controller has four gain parameters (K_{pc1} , K_d , K_{pc2} and K_i) to be tuned to satisfy the objectives of using the controller to control the steam turbine and provide good control system performance for reference and disturbance inputs.
- To control the steam turbine for reference input tracking, the transfer function of the closed loop control system is derived using the block diagram and Eqs.3 and 14.
- The PD-PI controller is tuned using the same tuning procedure used with the 2/2 second-order and I-PD compensators.
- The tuned parameters of the PD-PI controller using an ITAE performance index^[19] are as follows:

$$K_{pc1} = -1.566796, \quad K_d = 537.90936$$

$$K_{pc2} = 350.5690, \quad K_i = 37728.398 \quad (15)$$

- Using the closed-loop transfer function of the closed-loop control system for reference and disturbance inputs using the controller parameters in Eq.15, the unit step time response is shown in Fig.5.

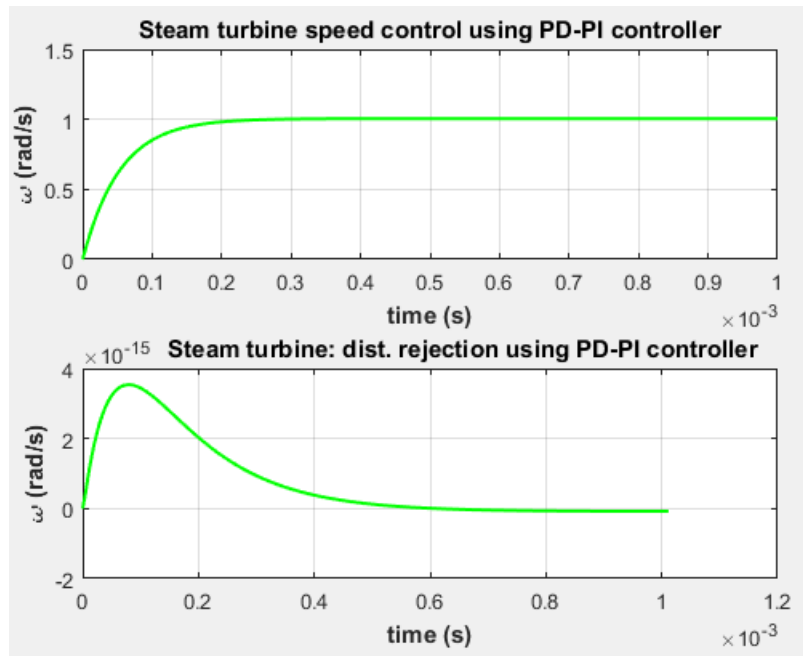

Figure 5: Step time response of the steam turbine load speed control using a PD-PI controller.

COMMENTS

- The PD-PI controller provided a reference input tracking step time response having the following characteristics:
 - ✚ Maximum percentage overshoot: 0.528%
 - ✚ Settling time: 0.196ms
- The success of the PD-PI controller to reject the disturbance input is measured by the following characteristics:
 - ✚ Maximum mold temperature step time response: 3.54×10^{-15} rad/s
 - ✚ Minimum mold temperature step time response: zero
 - ✚ Settling time to zero (approximate): 1ms

Controlling the Steam Turbine Speed Using a 2DOF-3 Controller

The 2DOF controller was introduced by the author to control a number of difficult processes since 2014 and used different structures of 2DOF control to control a variety of industrial processes with bad dynamics such as: liquefied natural gas pressure control^[30], coupled dual

liquid tanks^[34], boost-glide rocket engine^[29], BLDC motor control^[35], highly oscillating second-order process^[25], delayed double integrating processes^[27], boiler drum water level^[32], boiler temperature^[31], electro-hydraulic drive^[37], rolling strip thickness^[38], IMM mold temperature^[39], IMM barrel temperature^[40], IMM cavity gate pressure^[41], IMM mold packing pressure^[42], IMM ram velocity^[43], full-electric IMM^[45], Al-Jazari turbine speed^[45], Banu Musa axial turbine power^[46] and wind turbine speed.^[47]

The structure of the 2DOF controller used in the present work is shown in Fig.6.^[42] The 2DOF-3 controller is composed of two control elements having the same control mode structure for a PD control to simplify the analysis of the control system using the 2DOF control structure.^[48]

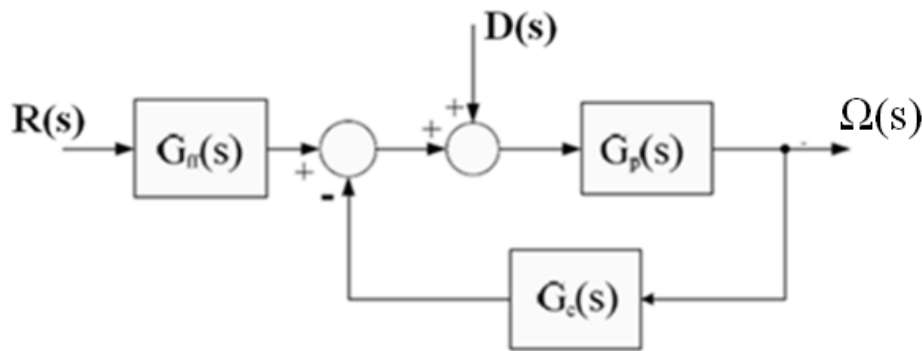

Figure 6: Steam turbine speed control using a 2DOF-3 controller.^[40]

The transfer functions of the 2DOF-3 controller are as follows:

$$G_{ff}(s) = K_{pc1} + K_{d1}s$$

$$\text{and } G_c(s) = K_{pc2} + K_{d2}s \quad (16)$$

Where: K_{pc1} = proportional gain of the PI-control mode.

K_{d1} = derivative gain of the feedforward PD control mode.

K_{pc2} = proportional gain of the feedback PD control mode.

K_{d2} = derivative gain of the feedback PD control mode.

The 2DOF-3 controller has four gain parameters to be tuned to provide the required performance of the closed-loop system of the steam turbine control. To overcome the problem of non-zero steady-state error associated with PD control mode, the transfer function of the closed loop control system of the steam turbine is derived from the block diagram of Fig.6 and Eq.16. Its investigation reveals the following condition for a zero steady-state error:

$$K_{pc2} = K_{pc1} - 1 \quad (17)$$

- From the stability analysis of the control system using the Routh-Hurwitz stability criterion^[49], the following condition is derived for the control system to be stable:

$$K_{d2} = 10K_{pc2} \quad (18)$$

- This means that K_{pc2} and K_{d2} are related to K_{pc1} and the tuning problem will be applied only for K_{pc1} and K_{d1} .
- Now, the 2DOF-3 controller is tuned following the same procedure used with the PD-PI controller. The tuned parameters of the 2DOF-3 controller are as follows:

$$\begin{aligned} K_{pc1} &= 160.70118, & K_{d1} &= 1645.01985 \\ K_{pc2} &= 159.70118, & K_{d2} &= 1597.01181 \end{aligned} \quad (19)$$

- The closed loop transfer functions of the control system for both reference and disturbance inputs are derived from the block diagram in Fig.6 using the process transfer function in Eq.3 and the controller transfer functions in Eq.16 with the tuned controller parameters in Eq.19. The unit step time response of the control system is plotted using the step command of MATLAB and shown in Fig.7 for both inputs.

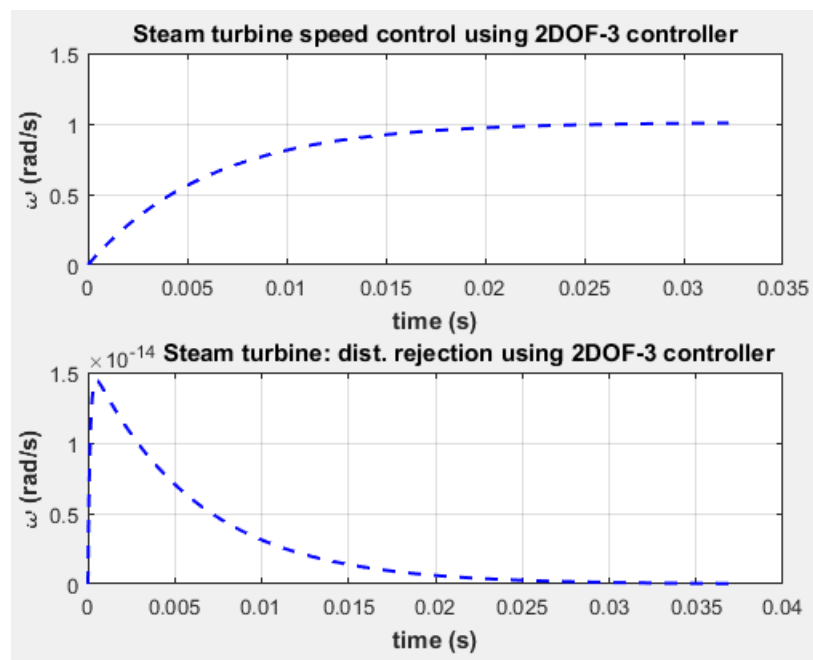

Figure 7: Step time response of the steam turbine load speed control using a 2DOF-3 controller.

COMMENTS

- The 2DOF-3 controller provided a reference input tracking step time response having the following characteristics:
 - ✚ Maximum percentage overshoot: 0.582 %
 - ✚ Settling time: 0.0214 s
- The success of the 2DOF-3 controller to reject the disturbance input is measured by the following characteristics:
 - ✚ Maximum mold temperature step time response: 1.442×10^{-14} rad/s
 - ✚ Minimum mold temperature step time response: zero
 - ✚ Settling time to zero (approximate): 0.03 s

Controlling the Steam Turbine Speed Using a Conventional PI Controller

- The conventional PI controller is still in use in controlling various processes such as: IMM ram velocity^[49], time delay systems^[50], hydraulic systems^[51], car cruse^[52], single stage transformerless grid tied PV systems^[53], water temperature in oil fired heaters^[54], DC motor speed^[55], temperature control^[56] and steam turbine frequency.^[4]
- The PI controller was tuned by the authors of reference.^[5] They used the PI controller gain parameters (K_{pc} and K_i):

$$K_{pc} = 20 \quad \text{and} \quad K_i = 1.3333 \quad (20)$$
- Using the process transfer function in Eq.3, the PI controller transfer function in Eq.14 with gain parameters given in Eq.20 and the block diagram incorporating the PI controller and controlled steam turbine speed process, the transfer functions for both reference and disturbance inputs are derived and used to draw the unit step time response of the control system using the MATLAB 'step' command.^[14] The result is presented in Fig.8.

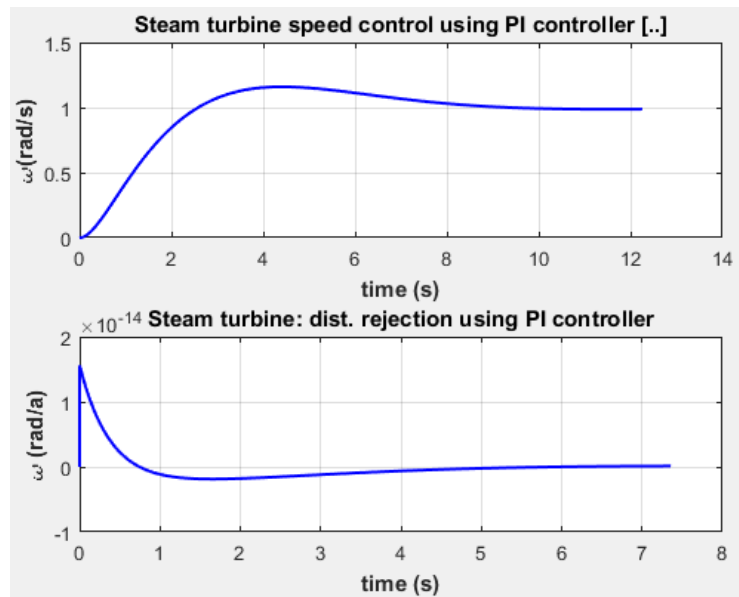

Figure 8: Step time response of the steam turbine load speed control using a PI controller.

COMMENTS

- The PI controller provided a reference input tracking step time response having the following characteristics:
 - ✚ Maximum percentage overshoot: 15.958 %
 - ✚ Settling time: 8.377 s
- The success of the PI controller to reject the disturbance input is measured by the following characteristics:
 - ✚ Maximum mold temperature step time response: 1.557×10^{-14} rad/s
 - ✚ Minimum mold temperature step time response: 1.863×10^{-14} rad/s
 - ✚ Settling time to zero (approximate): 6.0 s

Characteristics Comparison of the Four Compensators/controllers with a PI controller

- The time-based characteristics of the control system for the steam turbine load control are quantitatively compared in Table 1 for reference input tracking and Table 2 for disturbance input.

Table 1: Reference input time-based characteristics of the steam turbine load control using 2/2 second-order, I-PD compensators and PD-PI, 2DOF-3, PI controllers.

Characteristics	2/2 second-order compensator	I-PD compensator	PD-PI controller	2DOF controller	PI controller
Maximum overshoot (%)	1.834	0	0.528	0.582	15.928
Settling time (s)	0.002	32.72	0.000196	0.0214	8.377

CONCLUSION

- The objective of the paper was to investigate the use and tuning of 2/2 second order compensator, I-PD compensator, PD-PI controller and 2DOF-3 controller to control a steam turbine load unit.
- The proposed two compensators and two controllers are from the second generation of control compensators/controllers presented by the author since 2014.
- The four compensators and controllers were tuned using the MATLAB optimization toolbox and the ITAE performance index.

Table 2: Disturbance input time-based characteristics of the steam turbine load control using 2/2 second-order, I-PD compensators and PD-PI, 2DOF-3, PI controllers.

Characteristics	2/2 second order compensator	I-PD compensator	PD-PI controller	2DOF-3 controller	PI controller
Maximum time response (10^{14} rad/s)	1.549	1.552	0.354	1.442	1.557
Minimum time response (10^{14} rad/s)	0	-0.08	0	0	-1.863
Approximate settling time to zero (s)	0.5	20	0.001	0.03	6

- A conventional PI controller from the first generation of PID controllers was used in a previous work to control the same steam turbine load unit taken in this work as a case study for the application of the proposed compensators/controllers. It was compared with the four proposed compensators/controllers.
- The 2/2 second order compensator succeeded to reduce the maximum overshoot to 1.834 % compared with 15.928 % for the PI controller and to reduce the settling time to 2.75 ms compared with 8.377 s for the PI controller for the reference input tracking.
- The I-PD compensator succeeded to eliminate completely the maximum overshoot of the control system compared with 15.928 % for the PI controller and settled after 32.72 s s compared with 8.377 s for the PI controller for reference input tracking.
- The PD-PI controller succeeded to reduce the maximum overshoot of the control system to 0.528 % compared with 15.928 % for the PI controller and succeeded to settle after 0.196 ms compared with 8.377 s for the PI controller for reference input tracking.
- The 2DOF-3 controller succeeded to reduce the maximum overshoot of the control system to 0.582 % compared with 15.928 % for the PI controller and succeeded to settle after 21.4 ms compared with 8.377 s for the PI controller for reference input tracking.
- The PD-PI controller was selected as the best compensator/controller within the proposed ones for its minimum settling time and second minimum maximum overshoot.
- The performance of the proposed compensators/controllers regarding disturbance rejection was excellent through the use of a high pass second-order filter receiving the disturbance input. Both maximum time response and settling time to zero were negligible indicating the success of all the presented compensators/controllers to suppress the input disturbance (except the settling time to zero of the I-PD compensator and PI controller).
- The PD-PI controller was selected as the best control element for both reference and disturbance inputs.

REFERENCES

1. Wikipedia, “Taqi ad-din Mohammed ibn Ma’ruf”, https://en.wikipedia.org/wiki/Taqi_ad_din_ibn_Maruf , 2024.
2. Wikipedia, “Steam turbine”, https://en.wikipedia.org/wiki/Steam_turbine, 2024.
3. Drax, “How turbines came to power the world”, https://en.wikipedia.org/wiki/History_of_wind_power, 2018.

4. Hamid, A. T., "Application of tuning control actions for the efficient load/frequency control in steam turbines", *International Journal of Current Engineering and Technology*, 2013; 3(5): 1895-1898.
5. Dulau, M. and Bica, D., "Mathematical modeling and simulation of the behavior of the steam turbine", *Procedia Technology*, 2014; 12: 723-729.
6. Rosyadi, M. et al., "Simplified model of variable speed wind turbine generator for dynamic simulation analysis". *IEEJ Transactions on Power and Energy*, 2015; 135(9): 538-549.
7. Ozcelik, S. and Celep, H., "Model based adaptive PID controller with parallel feedforward compensator for steam turbine speed control", *International Journal of Engineering Research & Technology*, 2016; 5(12): 416-422.
8. Dettori, S., Iannino, V., Colla, V. and Signorini, A., "A fuzzy logic based tuning approach of PID control for steam turbines for solar applications", *Energy and Procedia*, 2017; 105: 480-485.
9. Reitinger, J. Cech, M. and Konigsmarkova, J. "Model-based control system design for steam turbine based on functional mockup interface", DOI: 10.1109/CarpathianCC.2018.8399693, May 2018.
10. Foyo, A., Thelkar, A., Bharatiraja, C. and Adedayo, Y., "Reference design and comparative analysis of model reference adaptive control for steam turbine speed control", *FME Transactions*, 2020; 48: 329-341.
11. Abdul-Majeed, F. A., "Steam turbine generator controller design based on particle swarm optimization", *Material Science and Engineering*, 2021; 1105: 14.
12. Nath, A., Tanni, T., Surja, A. and Iqbal, M., "An improved load frequency control strategy for single and multi-area power system", *International Conference on Advancement in Electrical and Electronic Engineering*, Gazipur, Bangladesh, 24-26 February; 2022: 1-6.
13. Gopi, P. et al., "Improving load frequency controller tuning with rat swarm optimization tuning and porpoising feedback detection for enhanced power system stability", *Scientific Reports*, 2024; 14: 15.
14. Mathworks, "Step response of dynamic system", <https://www.mathworks.com/help/ident/ref/dynamicsystem.step.html>, 2024.
15. Hassaan, G. A., "On tuning a novel feedforward second-order compensator to control a very slow second-order-like process", *International Journal of Advanced Research in Computer Science & Technology*, 2014; 2(3): 326-328.

16. Hassaan, G. A., "Disturbance rejection associated with a highly oscillating second-order-like process, Part I: Feedforward second-order compensator", *International Journal of Computer techniques*, 2015; 2(4): 90-95.
17. Hassaan, G. A., "Temperature control of a greenhouse using feedforward first-order, 2/2 second-order, notch and I-PD compensators", *World Journal of Engineering Research and Technology*, 2023; 9(11): 14-29.
18. Hassaan, G. A., "Boiler steam pressure control using I-PD, PI-first-order and 2/2 second-order compensators", *ibid*, 2024; 10(3): 57-73.
19. Martins F., "Tuning PID controllers using the ITAE criterion", *International Journal of Education*, 2005; 21(5): 867-873.
20. Lopez, C., "MATLAB optimization techniques", Apress, 2014.
21. Hassaan, G. A., "Tuning of novel I-PD compensator used with second-order-like processes", *International Journal of Computer techniques*, 2023; 10(2): 1-7.
22. Hassaan, G. A., "Control of a rocket pitch angle using PD-PI controller, feedback first-order compensator and I-PD compensator", *International Journal of Computer Techniques*, 2024; 11(1): 1-8.
23. Hassaan, G. A., "Rolling strip thickness control using I-P, I-PD and PI-first order compensators compared with an adaptive PI controller", *World Journal of Engineering Research and Technology*, 2024; 10(3): 50-64.
24. Hassaan, G. A. "Tuning of PD-PI controller used with first-order delayed process", *International Journal of Engineering Research and Technology*, 2014; 3(4): 51-55.
25. Hassaan, G. A. "Tuning of PD-PI controller used with a highly oscillating second-order process", *International Journal of Science and Technology Research*, 2014; 3(7): 145-147.
26. Hassaan, G. A., "Tuning of PD-PI controller used with an integrating plus time delay process", *International Journal of Scientific & Technical Research*, 2014; 3(9): 309-313.
27. Hassaan, G. A., "Controller tuning for disturbance rejection associated with delayed double integrator process, Part I: PD-PI controller", *International Journal of Computer Techniques*, 2015; 2(3): 110-115.
28. Hassaan, G. A., "Tuning of PD-PI controller used with a third-order process", *International Journal of Application or Innovation in Engineering Management*, 2020; 9(8): 6-12.

29. Hassaan, G. A., "Control of a boost-glide rocket engine using PD-PI, PI-PD and 2DOF controllers", International Journal of Research Publication and Reviews, 2023; 4(11): 913-923.
30. Hassaan, G. A., "Liquefied natural gas tank pressure control using PID, PD-PI, PI-PD and 2DOF controllers", World Journal of Engineering Science and Technology, 2024; 10(2): 18-33.
31. Hassaan, G. A., "Control of boiler temperature using PID, PD-PI and 2DOF controllers", International Journal of Research Publication and Reviews, 2024; 5(1): 5054-5064.
32. Hassaan, G. A., "Control of Boiler-drum water level using PID, PD-PI, PI-PD and 2DOF controllers", International Journal of Engineering and Techniques, 2024; 10(1): 10.
33. Hassaan, G. A., "Tuning of PD-PI and PI-PD controllers to control the internal humidity of a greenhouse", International Journal of Engineering and Techniques, 2023; 9(4): 9.
34. G. A. Hassaan, G. A., "Tuning of controllers for reference input tracking of coupled-dual liquid tanks", World Journal of Engineering Science and Technology, 2022; 8(2): 86-101.
35. Hassaan, G. A., "Tuning of controllers for reference input tracking of a BLDC motor", International Journal of Progressive Research in Engineering, Management and Science, 2022; 2(4): 5-14.
36. Hassaan, G. A., "Furnace control using I-PD, PD-PI and 2DOF controllers compared with fuzzy-neural controller", International Journal of Computer Techniques, 2024; 11(2): 10 pages.
37. Hassaan, G. A., "Control of an electro-hydraulic drive using PD-PI, PI-PD and 2DOF-2 controllers compared with a PID controller", International Journal of Engineering and Techniques, 2024; 10(2): 10.
38. Hassaan, G. A., "Strip thickness control using PD-PI, PI-PD and 2DOF-2 controllers compared with single model adaptive Smith predictor", International Journal of Computer Techniques, 2024; 11(2): 10 pages.
39. Hassaan, G. A., "Thermoplastics injection molding machine control, Part I: Mold temperature control using I-PD compensator, PD-PI and 2DOF-2 controllers compared with a PID controller", World Journal of Engineering Research and Technology, 2024; 10(5): 147-164.
40. Hassaan, G. A., "Thermoplastics injection molding machine control, Part II: Barrel temperature control using PD-PI, PI-PD and 2DOF-2 controllers compared with ANN-PI controller", International Journal of Engineering and Techniques, 2024; 10(3): 6-15.

41. Hassaan, G. A., "Thermoplastics injection molding machine control, Part III: Cavity gate pressure control using I-PD, PD-PI, and 2DOF-2 controllers and I-P compensator compared with a PID controller", *International Journal of Research Publication and Reviews*, 2024; 5(5): 4387-4398.
42. Hassaan, G. A., "Thermoplastics injection molding machine control, Part IV: Mold packing pressure control using I-PD, PD-PI, PI-PD and 2DOF-2 controllers compared with an adaptive IMC controller", *International Journal of World Journal of Engineering Research and Technology*, 2024; 10(6): 94-114.
43. Hassaan, G. A., "Thermoplastics injection molding machine control, Part V: Ram velocity control using I-PD, PD-PI, PI-PD and 2DOF-3 controllers compared with improved PID controller", *International Journal of Computer Techniques*, 2024; 11(3): 42-52.
44. Hassaan, G. A., "Thermoplastics injection molding machine control, Part VI: Full-electrical IMM control using PD-PI, PI-PD and 2DOF-4 controllers compared with a PI controller", *International Journal of Engineering and Techniques*, 2024; 10(3): 157-166.
45. Hassaan, G. A., "Power turbines control, Part I: Al-Jazari turbine control using I-PD, PD-PI, 2DOF-3 and PI-PD controllers compared with a PI controller", *International Journal of Research Publication and Reviews*, 2024; 5(7): 175-186.
46. Hassaan, G. A., "Power turbines control, Part II: Banu Musa axial turbine power control using PD-PI, PI-PD and 2DOF-3 controllers compared with a PI controller", *International Journal of Engineering and Techniques*, 2024; 10(4): 86-97.
47. Hassaan, G. A., "Power turbines control, Part III: Wind turbine speed control using PD-PI, PI-PD and 2DOF-3 controllers compared with a PI controller", *International Journal of Computer Techniques*, 2024; 11(4): 11-21.
48. Hassaan, G. A., "Temperature control of a greenhouse using PD-PI, PI-PD and 2DOF controllers", *International Journal of Engineering Inventions*, 2023; 12(9): 156-167.
49. Tan, K. and Tang, J., "Learning enhanced PI control of ram velocity in injection molding machines", *Engineering Applications of Artificial Intelligence*, 2002; 15(1): 65-72.
50. Bakasova, M., Vanekova, K. and Zavacka, J., "PI controller design for time delay systems", *IFAC Proceedings Volumes*, 2010; 43(2): 349-354.
51. Dubonjic, L., Nedic, N., Filipovic, V. and Prgic, D., "Design of PI controllers for hydraulic control systems", *Mathematical Problems in Engineering*, 2013; 2013: 10.

52. Deka, J. and Haloi, R., “Study of effect of P, PI controllers on car cruise control system and security”, International Journal in Advanced Research in Electrical, Electronics and Instrumentation Engineering, 2014; 3(6): 9817-9822.
53. Chigane, K. and Ouassaid, M., “Online control using ANN-PI controller for single stage transformerless grid tied PV system”, International Symposium on Advanced Electrical and Communication Techniques, Rabat, Morocco, 21-23 November 2018; 1-69.
54. Ismail, S., Hussain, Z. Thabit, H. and Thabit, T., “Using PI controller unit for controlling the water temperature in oil fired heaters by PLC technique”, Przegląd Elektrotechniczny, 2021; 97(3): 157-161.
55. Sayyad, S. and Gavhance, W., “DC motor speed control using PI controller”, International Journal of Instrumentation in Engineering Research and Technology, 2022; 9(4): 107-109.
56. Wahyudi, M. et al., “Temperature control using PI controller”, Journal of Emerging Supply Chain, Clean Energy and Power Engineering, 2022; 1(1): 75-83.