

**A LABORATORY DESIGN MODEL FOR BUILDING'S HEATING,  
VENTILATION AND AIR CONDITIONING USING  
PROGRAMMABLE LOGIC CONTROLLER AND SUPERVISORY  
CONTROL AND DATA ACQUISITION**

**B.I Aldi<sup>1</sup>, Dr. J.S Kadadevarmath<sup>\*2</sup> and N.P Bannibagi<sup>3</sup>**

<sup>1</sup>Research Scholar, Department of Physics and Electronics Karnatak University, Dharwad,  
Karnataka, India.

<sup>2</sup>Professor, Department of Electronics Karnatak University, Dharwad, Karnataka, India.

<sup>3</sup>Assistant Director, Advanced Training Institute for Electronics and Process Instrumentation,  
Telangana, Andhra Pradesh, India.

Article Received on 04/05/2016

Article Revised on 25/06/2016

Article Accepted on 15/07/2016

**\*Corresponding Author**

**Dr. J.S. Kadadevarmath**

Professor, Department of  
Electronics Karnatak  
University, Dharwad,  
Karnataka, India.

**ABSTRACT**

The objective of this paper is to design and build the prototype automatic control system for Heating, Ventilation and Air conditioning (HVAC), to maintain the comfortable environmental conditions inside the building using Programmable Logic Controller (PLC). Allen Bradley Micro Logix 1100, 1763-L1BBB PLC is used for automatic

control of temperature, humidity and circulation of air within the room. The system consists of an interfaced hardware module and sensors for temperature and humidity control. Compact system is designed to provide temperature range within 23°C to 26°C and humidity range within 60% to 70% RH (Relative Humidity). The PLC continuously monitors the weather conditions of Hubballi-Dharwad twin cities and controls the HVAC to get the comfort environmental conditions within the laboratory of the department of Electronics, Karnatak University, Dharwad. The relevant data are recorded by supervisory control and data acquisition (SCADA) system.

**KEYWORDS:** Air conditioner, heater, ladder diagram, PLC, SCADA, sensors.

## 1. INTRODUCTION

An efficient building is the one that uses a technology to provide an efficient heating, ventilation, air conditioning, lighting and other electrical services by consuming less electrical energy.<sup>[1]</sup> A building automation system (BAS) is a computer network of system that integrates the control of various electrical and mechanical systems. There are two main techniques for implementing BAS: integrating a number of existing control systems and creating a new distributed control network to achieve the said objectives. This method of approach may serve to provide effective and efficient management of systems in a building. Indoor Air Quality (IAQ) is more frequently used term in BAS and it depends on the factors such as thermal regulation, control of circulating air, occupants' activities, operation and maintenance of building systems.<sup>[2]</sup> HVAC (Heating, Ventilation and Air Conditioning) is thus the methodology of providing indoor environmental comfort based on IAQ. Heating system maintains adequate room temperature both in cold and hot weather conditions. Ventilation maintains humidity and air circulation so as to keep comfortable environment in a building.<sup>[3, 4]</sup> A number of modern techniques have been proposed for improving HVAC control. Some of these are the use of genetic algorithms and neural networks for control optimization to incorporate the desirable levels of living quality in Building Energy Management System (BEMS).<sup>[5, 6]</sup> A typical HVAC system may contains thousands of sensors and actuators for measuring, monitoring and controlling temperature, airflow, humidity and duct pressure within the building.<sup>[7]</sup> Among various methodologies available for HVAC control, we adopted programmable logic controller (PLC) based control method and is found to be promising. PLC is an electronic control device used in most of the industrial process control applications. This has central processor unit (CPU), power supply unit, input/output (I/O) modules and program terminals.<sup>[8-10]</sup> According to National Electrical Manufacturers Association (NEMA), PLC is a digitally operated electronic apparatus which uses a programmable memory for the internal storage of instructions and for implementing specific functions such as logic, sequencing, timing, counting and arithmetic control operations through digital or analog I/O modules. The connections are established by means of field buses, such as process field bus (PROFIBUS) or Ethernet.<sup>[11]</sup> PLCs provide many advantages over conventional relay type of control due to increased reliability, more flexibility, lower cost, easy to install, communication capability, faster response time and convenient to troubleshoot.<sup>[12,13]</sup> Their application is not limited to a particular field. Hence they have been popularized as system controllers to perform automatic operations of electrical and electronic devices in the industrial process control. Some of their applications

includes control of diesel generator sets<sup>[14]</sup>, spraying toxic chemicals in the agriculture field by using robots<sup>[15]</sup>, industrial crane automation and monitoring<sup>[16]</sup>, stepper motor control<sup>[17]</sup>, conveyor control<sup>[18,19]</sup> and elevator control<sup>[20,21]</sup> systems. Keeping these potential applications, it is proposed to implement a prototype automatic HVAC control system using PLC. Further, supervisory control and data acquisition (SCADA) system is interfaced to monitor and display the control operations on personal computer (PC).<sup>[22, 23]</sup> Apart from the introduction in the first section, the paper has following sections. The second section is devoted to the presentation of adopted methodology. The third section is devoted to the presentation of hardware description of each system blocks. The fourth section discusses the development of software for interfacing with the hardware module. Results obtained by the implemented module and their discussion are presented in the fifth section. Last section summarizes the conclusions.

## 2. METHODOLOGY

As illustrated in figure 1, the HVAC control model's philosophy is based on the general concept of automatic control with the capability of being adapted to any building's specific requirements. The model includes sensors, heater, air conditioner (AC), ventilator and a PLC controller with the capability of interaction with the sensors for controlling HVAC system. The control program for the automatic operation of system is entered into the PLC memory through PC. Based on this program PLC read inputs from input modules consists of temperature sensor and humidity sensor and generates control logic signals to output modules which include heating, ventilation window and AC. Further, the information of the system is recorded and monitored by the SCADA software on PC interfaced to PLC through industrial communication interface system (ICIS).

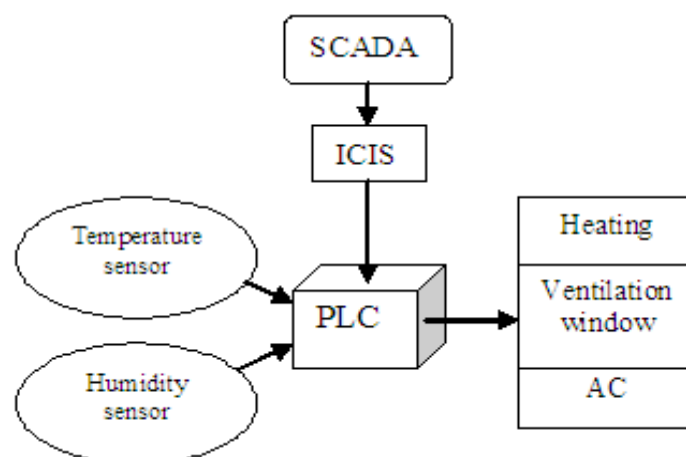

**Figure 1: Block diagram of SCADA supervised HVAC Control.**

### 3. Hardware description of system blocks

Hardware configuration of HVAC includes PLC, temperature sensor, humidity sensor, heater, AC, ventilation window and other essential circuits as seen in figure 2. The program is developed and implemented by using Allen Bradley MicroLogix 1100, 1763-L1BBB PLC. This includes expansion analog module 1762-IF20F2 and is having 12 inputs (10 digital, 2 analog), 6 digital outputs, isolated RS-232/RS-485 combination port for serial and networked communication.

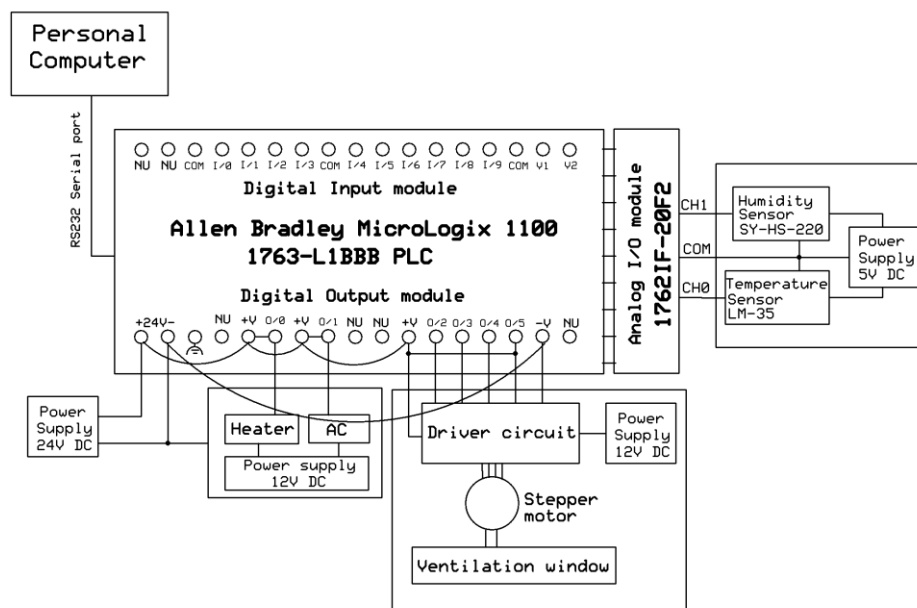

**Figure 2: Schematic diagram of HVAC hard ware control.**

#### 3.1 Temperature and Humidity sensors

The circuit shown in figure 3 includes temperature sensor LM-35 and humidity sensor SY-HS-220. The PLC analog module receives the signals from these sensors and converts the temperature and relative humidity to corresponding output voltages. The features of temperature sensor and humidity sensor are listed in Table 1 and Table 2 respectively.

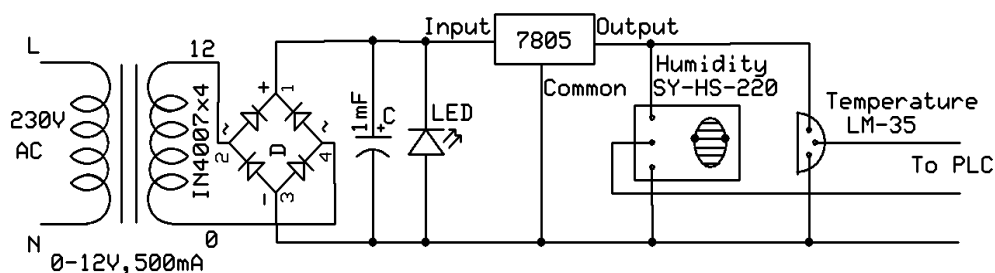

**Figure 3: Supply circuit for sensors.**

**Table 1: Parameters of temperature sensor LM-35.**

Parameter	Value
Linear Scale factor	+10mV/°c
Operating temperature range	-55 °C to +150 °C
Output voltage range	-550mV to +1500 mV
Operating voltage	4 to 30 V
Maximum Drain current	60µA
Minimum output impedance	0.1Ω for 1mA load

**Table 2: Parameters of humidity sensor SY-HS-220.**

Parameter	Value
Operating humidity range	30-90% RH
Operating temperature range	0 to 60 °C
Current consumption	<3.0mA
Storage humidity	Within 95% RH
Supply voltage	5 V
Output voltage range	990mV to 2970 mV

### 3.2 Stepper motor

Modern buildings use motors and drives<sup>[24]</sup> for proper air circulation. However in our prototype model unipolar pulse modulated (PM) stepper motor is used for this purpose. This is a brushless, synchronous electric motor that converts digital pulses into mechanical shaft rotations, moves in discrete steps and used for precise value of rotation in each steps for opening and closing the ventilation window. Figure 4 shows the schematic diagram of stepper motor driver used for the control of ventilation window based on the control signals from the digital outputs of the PLC, derived from the humidity sensor SY-HS-220 analog input. Every rotation of the stepper motor is divided into a discrete number of 200 steps. In each step, stepper motor rotates at a precise angle of 1.8°. As the frequency of the digital pulses increases, the step movement of the stepper motor changes into a continuous rotation. Four binary digital pulses from the PLC are given to four opto couplers MCT2E. The outputs of each opto couplers are given to base of the four TIP 122 transistors Q1, Q2, Q3 and Q4 respectively to drive the motor. The stepping sequences of the digital pulses are shown in Table 3. The digital value 1 indicates ON state and digital value 0 indicates OFF state of the pulses. These stepping sequences cause the stepper motor to rotate in clockwise direction to open the ventilation window. In order to close the window, excitation sequences of the stepper motor are to be reversed to rotate the stepper motor in the anticlockwise direction.

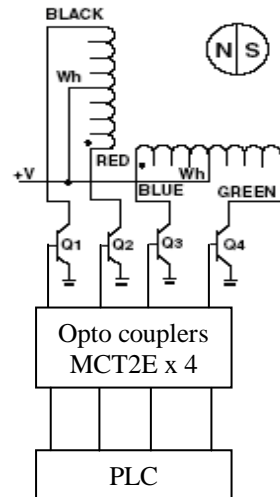

Figure 4: Schematic diagram of stepper motor driver circuit.

Table 3: Digital pulse sequences for the operation of stepper motor.

Steps	Q <sub>1</sub>	Q <sub>2</sub>	Q <sub>3</sub>	Q <sub>4</sub>
1	1	0	1	0
2	0	1	1	0
3	0	1	0	1
4	1	0	0	1

### 3.3 Heater and AC

Two 12V relays are used for switching heater and AC based on the control signals of the PLC appear at terminals A and B shown in figure 5. The control signals are derived from temperature sensor LM-35.

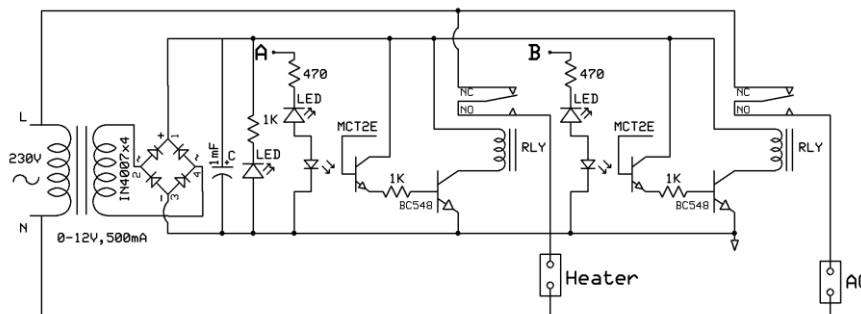

Figure 5: Circuit for controlling heater and AC.

### 4. Development of software for interfacing PLC

The procedure for automatic control of HVAC is programmed in the PLC as per the specifications mentioned. This program is compiled in run mode by the RSLogix micro starter lite (V8.10) ladder diagram (LD) logic software installed in the PC. This software is supplied along with Micrologix1100 programmable logic controller. Analog module 1762-

IF20F2, read the outputs of temperature and humidity sensors. RSLinx classic lite software was used to configure the hardware and software. The LD programming method was used for the development of control program. These are the graphical programming languages use relay ladder logic software device to emulate the hardwired devices.<sup>[25-27]</sup> LD program instructions communicate with control equipments namely humidity sensor, temperature sensor, stepper motor and relays to accomplish heating and AC operations as per the design considerations. Here, the PLC acts as an inner loop controller of HVAC system.

Figure 6 shows the flow chart of the PLC's software for the HVAC monitoring and control system. The software monitors the temperature range in ( $^{\circ}\text{C}$ ) and humidity range in percentage of relative humidity RH. Software also controls the open/close operations of ventilation window using stepper motor and ON/OFF states of the relays for both AC and Heater. For the optimum comfort of IAQ, weather conditions of the Hubbali city are considered. Weather data are collected from "The Weather Channel" forecast by the International Business Machine (IBM) Corporation<sup>[28]</sup>, and "Time and Date AS" channel of private limited company owned by Steffen Norwegian.<sup>[29]</sup> Based on these data temperature range is set between  $23^{\circ}\text{C}$  to  $26^{\circ}\text{C}$  and humidity range between 60%RH to 70%RH.

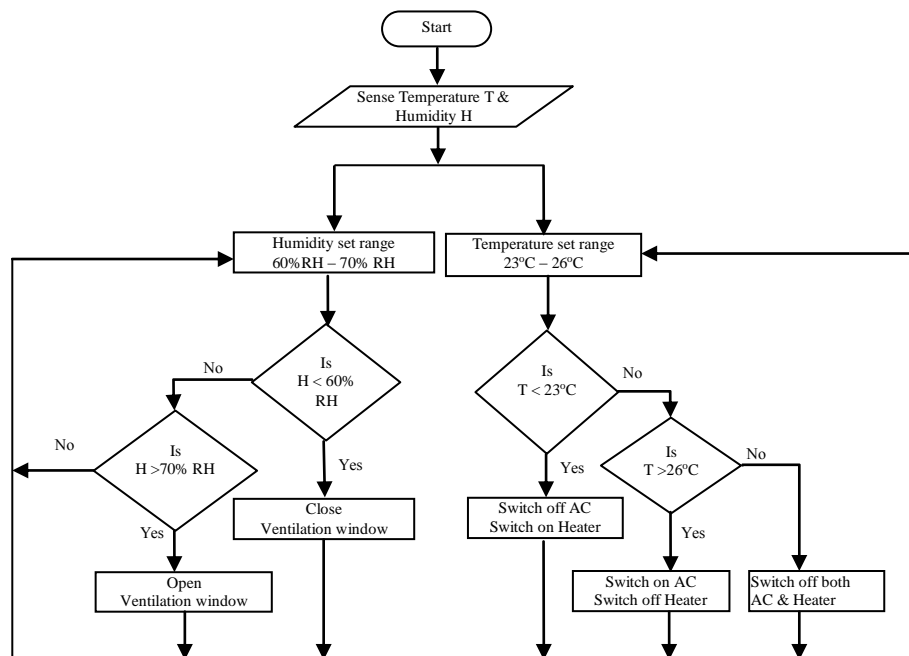

**Figure 6: Flow chart of HVAC control.**

**Table 4: Control actions of PLC**

Temperature T	Heater	AC	Humidity H	Ventilation window
23 °C to 26 °C	0	0	60% RH to 70% RH	NOP
T < 23 °C	1	0	H < 60% RH	Close
T > 26 °C	0	1	H > 70% RH	Open

Table 4 indicates the control logic for Hubballi city weather. If the temperature is within the range of 23°C to 26°C, both AC and heater will switch OFF (0). If the temperature is less than 23°C, then PLC allow heater to switch ON (1) and AC to switch OFF (0). If the temperature is above 26°C, then PLC allows the AC to switch ON and heater to turn OFF. At the same time PLC also monitors the humidity. If the humidity is within set range of 60% RH to 70% RH, then ventilation window will not operate (NOP). That is the window is either in closed or open state till the humidity goes beyond the set range. If it is less than 60% RH, then ventilation window will close and if it is more than 70% RH, then ventilation window will open in order to allow circulation of air. This is how the PLC is programmed to monitor and control the inner loop of the HVAC in building. Also window-based SCADA is implemented to communicate with HVAC for data acquisition and monitoring the control operations through the PLC. A SCADA application responds according to the system logic requirements or operator requests. Hence, the SCADA is said to perform the outer control loop of the HVAC system.<sup>[30]</sup>

## 5. RESULTS AND DISCUSSION

The proposed HVAC system as per the design criteria mentioned was subjected for test in the laboratory of the department of Electronics, Karnatak University - Dharwad. Initially, the characteristics of both humidity and temperature sensors were studied over a wide range of humidity and temperature from 40% RH to 85% RH and 18°C to 35°C respectively. Table 5 shows the humidity values and the corresponding voltage levels. Table 6 shows temperature values and the corresponding voltage levels. Analog voltages were determined as per the specifications given for these sensors. These voltages are then converted to digital values by ADC which is a built-in subsystem of PLC. A plot showing digital values versus humidity/temperature is shown in figure 7. It is observed that the digital values vary linearly with the variation both in humidity and temperature.



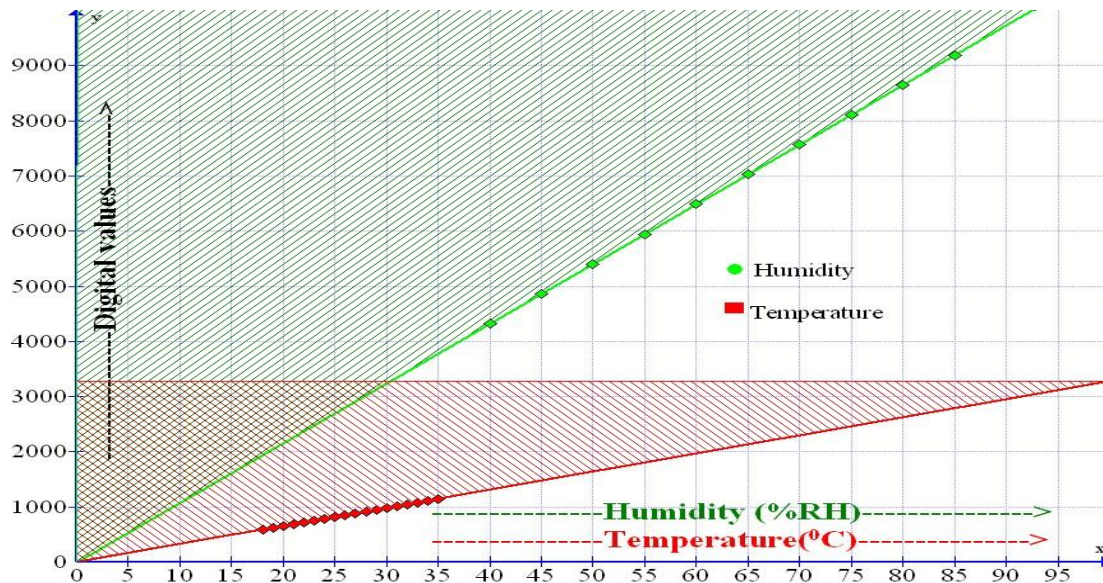

**Figure 7: Variation of digital values as a function of humidity and temperature.**

The developed LD program for the proposed scheme is then tested for its control operations and the consequent results were monitored in the SCADA menu. Status of AC and heater when the system was tested at temperature 23°C and humidity 40%RH is shown in figure 8. This menu indicates the ON/OFF status of Heater, AC (based on the temperature) and ventilation window (based on the humidity). Statuses are indicated by the Red and Green circular indicators. Red shows the OFF status and Green shows the ON status of the field devices. Observed menu can also be used to determine the instantaneous values of temperature and humidity as a function of time. Figure 9 shows the implemented prototype HVAC model controlled and monitored by PLC and SCADA.

**Table 5: Observed voltage and digital values of humidity sensor**

Humidity (%RH)	Voltage (mV)	Digital value
40	1320	4324
45	1485	4865
50	1650	5405
55	1815	5946
60	1980	6486
65	2145	7027
70	2310	7567
75	2475	8108
80	2640	8648
85	2805	9189

Table 6: Observed voltage and digital values of temperature sensor

Temperature (°C)	Voltage (mV)	Digital values
18	180	589
19	190	622
20	200	655
21	210	687
22	220	720
23	230	753
24	240	786
25	250	819
26	260	851
27	270	884
28	280	917
29	290	950
30	300	982
31	310	1015
32	320	1048
33	330	1081
34	340	1113
35	350	1146

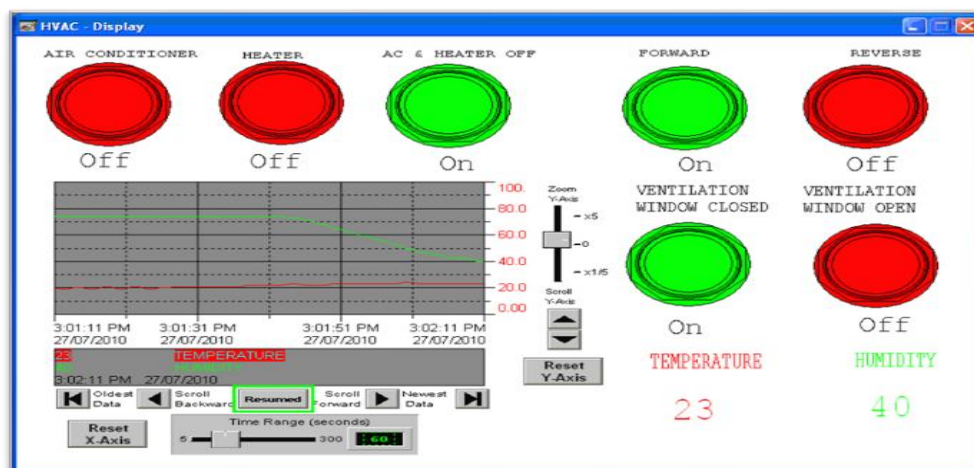

Figure 8: SCADA menu indicating status of HVAC.



Figure 9: Implemented prototype to test the HVAC system.

Table 7: Comparison with Hubballi-Dharwad weather conditions.

Time	Temperature (°C)	Humidity (%RH)	Controller actions		
			Heater	AC	Ventilation window
07:00 AM	23	40	0	0	Close
08:00 AM	24	50	0	0	Close
09:00 AM	25	50	0	0	Close
10:00 AM	26	60	0	0	NOP/ Close
11:00 AM	27	60	0	1	NOP/ Close
12:00 PM	27	70	0	1	NOP/ Close
01:00 PM	27	70	0	1	NOP/ Close
02:00 PM	26	80	0	0	Open
03:00 PM	25	70	0	0	NOP/ Open
04:00 PM	25	70	0	0	NOP/ Open
05:00 PM	25	60	0	0	NOP/ Open
06:00 PM	25	50	0	0	Close
07:00 PM	24	50	0	0	Close
08:00 PM	24	40	0	0	Close
09:00 PM	23	40	0	0	Close
10:00 PM	23	40	0	0	Close
11:00 PM	22	40	1	0	Close
12:00 AM	22	40	1	0	Close
01:00 AM	22	30	1	0	Close
02:00 AM	22	30	1	0	Close
03:00 AM	22	30	1	0	Close
04:00 AM	22	30	1	0	Close
05:00 AM	22	30	1	0	Close
06:00 AM	22	40	1	0	Close

Verification and validation of the control LD program is then performed in comparison with forecasted weather conditions of Hubballi-Dharwad twin city provided by the Microsoft network (msn).<sup>[31]</sup> Forecasted conditions such as temperature and humidity between 7:00 AM to next day 6:00 AM during winter day are recorded as shown in Table 7. It also shows control logic states of AC, Heater and Ventilation window. These states satisfy the designed considerations as discussed in section 4. During the time interval between 7:00 AM to 09:00AM, temperature was between 23 °C to 25 °C and humidity range was between 40% RH to 50% RH, thus the conditions of Heater, AC and Ventilation window will be zero, zero and Close respectively. At time 10:00 AM, temperature was 26 °C and humidity was 60% RH, thus the conditions of Heater, AC and Ventilation window will be zero, zero and NOP/Close. The NOP state is the state at which no action on Ventilation window is initiated and is either open or close state. i.e., it retains previous state. During the time interval

between 11.00 AM and 1.00 PM the temperature was at 27°C and humidity range was between 60% RH to 70% RH thus the Heater is at zero, AC switches to one state and Ventilation window is at NOP/Close. During the time interval between 02:00 PM to 5:00 PM the temperature was between 26°C and 25 °C and the humidity varied between 80 %RH to 60%RH, thus Heater, AC and Ventilation window will be zero, zero and Open respectively. During the time interval between 6:00 PM to 10:00 PM the temperature was between 25 °C and 23 °C and humidity varied between 50% RH to 40% RH, thus the Heater, AC and Ventilation window will be zero, zero and Close. During 11.00 PM to 6.00 AM the temperature was at 22°C and humidity varied between 40% RH to 30% RH thus Heater, AC and Ventilation window will be one, zero and Close respectively. Based on these observations it may be concluded that the environment of the laboratory is said to possess comfortable environment, thus the proposed hardware model is said to operate satisfactorily as per our design criteria.

## 6. CONCLUSIONS

The prototype HVAC model using Allen Bradley MicroLogix 1100, 1763-L1BBB PLC and SCADA has been designed and implemented. The system consists of an interfaced hardware module and sensors for temperature and humidity control. Temperature and humidity sensors were LM-35 and SY-HS-220 respectively. PLC enables automatic control of temperature, humidity and circulation of air within the room by the interfaced hardware module and sensors. Designed compact system maintains the temperature between 23°C to 26°C and humidity within 60% to 70% RH in the laboratory based on the weather conditions of Hubballi-Dharwad twin cities. The relevant data were recorded by supervisory control and data acquisition system. Lastly, it may be inferred that, the proposed hardware model may be used as an educational kit in understanding the role of PLC in control applications.

## REFERENCES

1. Piette M. A, Kiliccote S and Ghatikar G (2008), “Linking continuous energy management and open automated demand response”, Paper presented at Grid Interop Forum; Atlanta, GA.
2. Ronak D, Adam NM, Barkwi S, Basharia Y and Mohd A (2012), “Tracer decay method for determining ventilation characteristics of naturally ventilated office”, International Journal of Engineering Research and Development, 4(6): 69-76.

3. Zhang Y, Wright J A and Hanby V I (2006), “Energy aspects of HVAC system configurations - problem definition and test Cases”, American Society of Heating, Refrigeration and Air-Conditioning Engineers (ASHRAE) Transactions, HVAC & RESEARCH, 12(3c): 871-88.
4. Rafiuly P, Kwok S and Ospelt C (2000), “Climate and designs strategies for Beijing and Shanghai”, MIT Department of Architecture, Building Technology. Beijing and Shanghai. China.
5. Iatropoulos K, Doukas H, Patlitzianas DK, Psarras J, Turlis N and Louizidis S (2006), “An expert model for monitoring building’s operations via BEMS”, International Workshop on Energy Performance and Environmental Quality of Buildings, Milos Island, Greece.
6. Joshi R, Arctic India Sales Indoor Air Quality (IAQ) ASHRAE Standard, Arctic India sales, India.
7. Taneja J, Krioukov A, Stephen D and Culler D (2013), “Enabling advanced environmental conditioning with a building application stack”, IEEE.
8. Yu Z and Wen-qing W (2011), “Dynamic flammable gases distributing device based on programmable logic controller”, Proceedings of the 5<sup>th</sup> Conference on performance-based fire and fire protection engineering. Journal of Engineering Procedia: Elsevier Ltd, 11: 719–22.
9. Birbir Y and Nogay HS (2008), “Design and implementation of PLC-based monitoring control system for three-phase induction motors fed by PWM inverter”, International Journal of systems applications, Engineering and development, 2(3): 128-135.
10. Rullan A (1997), “Programmable logic controllers versus personal computers for process control”, Journal of Computers in Industrial Engineering, Elsevier Science Ltd, 33; 1-2: 421-24.
11. Samanta T, Sarkar D and Dasgupta S (2005), “PC-PLC based vacuum control system for superconducting cyclotron at VECC”, Proceedings of the 10<sup>th</sup> ICALEPCS International Conference on Accelerator and Large Experimental Physics Control Systems, Geneva., 100-105.
12. Guo L and Pecan R (2008), “Design projects in a programmable logic controller (PLC) course in electrical engineering technology”, ASEE Annual Conference & Exposition.
13. Rehg J (2002), “PLC laboratories – The next generation,” ASEE Annual Conference & Exposition.

14. Bhowmik PK, Dey M and Dhar S K (2009), "PLC based operation and control of two diesel generator set", *Journal of Electrical Engineering, The Institution of Engineers, Bangladesh*, 36(2): 43-46.
15. Lashin M M (2014), "Different applications of programmable logic controller", *Engineering and Information Technology, International Journal of Computer Science*, 4(1): 27-32.
16. Burali Y N (2012), "PLC based industrial crane automation and monitoring", *International Journal of Engineering and Science, Research Inventy*, 1(3): 1-4.
17. Bogdan L (2011), "PLC as a driver for stepper motor control", *Conference Annual session of Science papers IMT, Research Gate*, 10-20.
18. Chitra S and Raghavan V (2014), "Conveyor control using programmable logic controller", *International Journal of Advancements in Research and Technology*, 3(8): 25-31.
19. Trivedi M, Sheoran V and Tailor D (2014). "An analysis and control of a closed loop conveyer system using PLC and sensors", *International Journal of Innovation and Emerging Research in Engineering*, 1(1): 1-6.
20. Sharma S et al., (2011), "Applications of PLC for elevator control system", *International Symposium on Devices MEMS, Intelligent Systems & Communication, International Journal of Computer Applications*, 4-7.
21. Htay S and Yi Mon S (2014), "Implementation of PLC based elevator control system", *International Journal of Electronics and Computer Science Engineering*, 3(2): 91-100.
22. Belkar S B, Desai A, Parit M H and Dakre A (2014), "PLC SCADA based distribution monitoring & control", *Multidisciplinary Journal of Research in Engineering and Technology*, 1(1): 105-110.
23. Shengwei W and Zhenjun M (2008), "Supervisory and optimal control of building HVAC Systems: A Review", *American Society of Heating, Refrigerating and Air-Conditioning Engineers, HVAC&R Research, Research Gate*, 14(1).
24. Warne D F (2005), *Newnes Electrical Power Engineer's Handbook*. 2<sup>nd</sup> Ed. An imprint of Elsevier, 279-312.
25. Peng SS (2004), "Ladder diagram and Petri-Net based discrete-event control design methods", *IEEE Transactions on System, Man and Cybernetics, Part C: Applications and Reviews*, 34(4): 523-531.
26. Michel G (1990), *Programmable logic controllers: Architectures and Application*. Chichester, U.K, Wiley.

27. Pessen W (1989), “Ladder diagram design for programmable controllers”, International Federation of Automated Control, Journal of Automatica, 25(3): 407–412.
28. The Weather Company (2016), an IBM Business. Armonk, New York. U.S.
29. Time and Date AS (2016), Weather channel, Stavanger, Norway.
30. Guedes LA (2010), Programmable logic controller. Luiz Affonso Guedes, editor. InTech, Croatia, 161-171.
31. The Microsoft Network (2016 June 23), Weather channel, U.S.