



**APPLICATION OF HYBRID DIVERSITY TECHNIQUES FOR  
IMPROVEMENT OF MICROWAVE RADIO LINK PERFORMANCE IN  
NIGER DELTA REGION**

**Nwabueze C. A. and Jaja V. I.\***

Department of Electrical and Electronics Engineering, Chukwuemeka Ojukwu University,  
Uli, Anambra State, Nigeria.

Article Received on 18/02/2017

Article Revised on 11/03/2017

Article Accepted on 31/03/2017

**\*Corresponding Author**

**Jaja, V. I.**

Department of Electrical  
and Electronics  
Engineering, Chukwuemeka  
Ojukwu University, Uli,  
Anambra State, Nigeria.

**ABSTRACT**

The impairment of microwave radio signal due to multipath interference has been major obstacle to reliable radio communication and a lot of effort and energy has been expended over the years on ways to overcome this limitation. Solutions have been proffered such as the use of frequency and space diversity. These techniques have their short falls, hence the need for the development of a technique

which will overcome these limitations and provide acceptable performance improvement. The Hybrid Diversity Technique proposed has the best link performance results with the highest link availability values of FM = 40.52 dB, RSL = -45.48 dB and FSL = 140.48 over other known link configuration models.

**KEYWORD:** Diversity Techniques, Microwave Radio Link, Fresnel Zones, Fade Margin, Pathloss.

**INTRODUCTION**

The ever expanding world of microwave communication is confronted with myriad of problems ranging from limited bandwidth to radio channel variation causing unreliable communication. Diversity techniques have been observed as an effective means of mitigating the effect of fading. Two types of diversity are generally considered. The first is the space diversity where antennas are separated in distance (at least  $\lambda$ ), the signals seen on each

antenna are experiencing different and independent fading conditions. The second is the hybrid diversity technique which entails the combination of frequency diversity and space diversity for the purpose of achieving extra performance on very long or difficult paths of microwave link.

Diversity ensures that the receiver receives multiple copies of the same transmitted signal. If these copies are affected by independent fading conditions, the probability of fading all the copies at the same time decreases (Bhaskar, 2009). Therefore, diversity helps to improve the quality of a wireless system. The basic concept behind diversity is that two or more radio paths carrying the same information are relatively uncorrelated. When one path is in a fading condition, often the other path is not undergoing a fade. These separate paths can be developed by having two channels separated in frequency. The two paths can also be separated in space and in time (Nitika and Deepak, 2012).

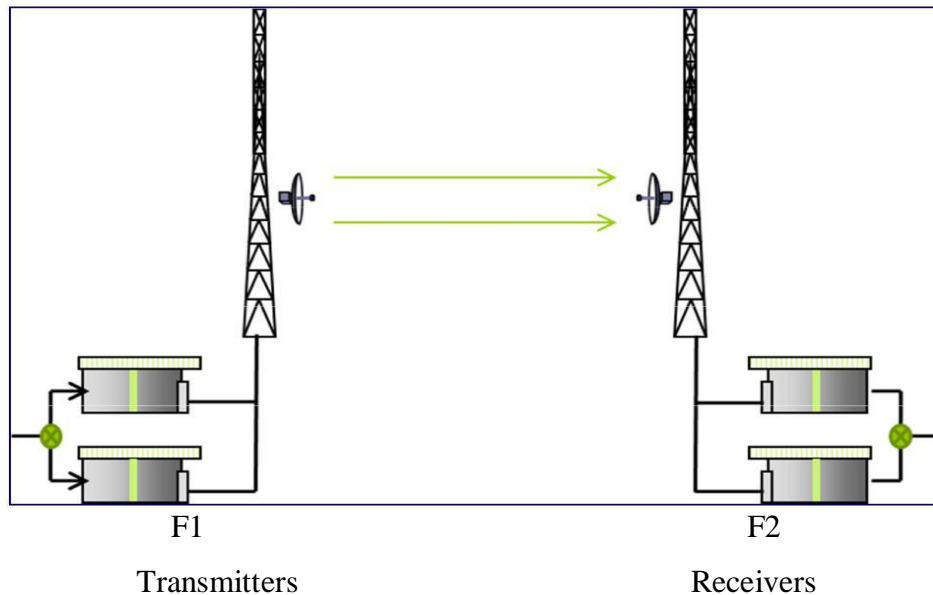
This paper presents a hybrid diversity performance result obtained from selected radio links. The results obtained were in very good agreement with known conventional techniques, and shows the highest link availability values.

### **Using diversity technique to improve overall microwave Link performance**

The basic idea of microwave radio diversity is to use two different antennas or frequencies and combine their signals in such a way as to improve overall radio system performance. Diversity is usually achieved using two vertically spaced antennas (space diversity), multiple transmitter frequencies (frequency diversity), both space and frequency diversity (hybrid diversity) (Mark and Zhuang, 2002).

Hafeth (2006) proposed diversity techniques as a system to help mitigate the effects of fading by providing multiple copies of the same signal to the receiver via different branches or paths (in frequency, time or even space, or combination of frequency and space) so that the probability that all paths will undergo the same amount of fading or deep-fades is reduced to great extent.

Figure 1 is an example of a frequency-diversity configuration, and can be used on a single link to provide redundancy.



**Figure 1: Frequency diversity techniques (Das, 2008).**

According to (Das, 2008), frequency diversity can also be used to combat all the three causes of unavailability, since the failure of a receiver or transmitter does not cause an outage and during routine maintenance, the traffic can be forced onto one of the Transmitter/Receiver paths. Also, since frequency diversity requires the use of two frequencies, this technique requires two transmitters and two receivers, therefore the system cost is high. Moreover, the limited microwave spectrum and obtaining a license for restricting the use of two different frequencies will make it difficult to use this technique. Frequency diversity is more complex and more costly than space diversity. Also, in frequency diversity technique, failure of one transmitter or one receiver will not interrupt service, and a transmitter and/or a receiver can be taken out of service for maintenance. The primary disadvantage of frequency diversity is that it doubles the amount of frequency spectrum required in this day and age when spectrum is at a premium.

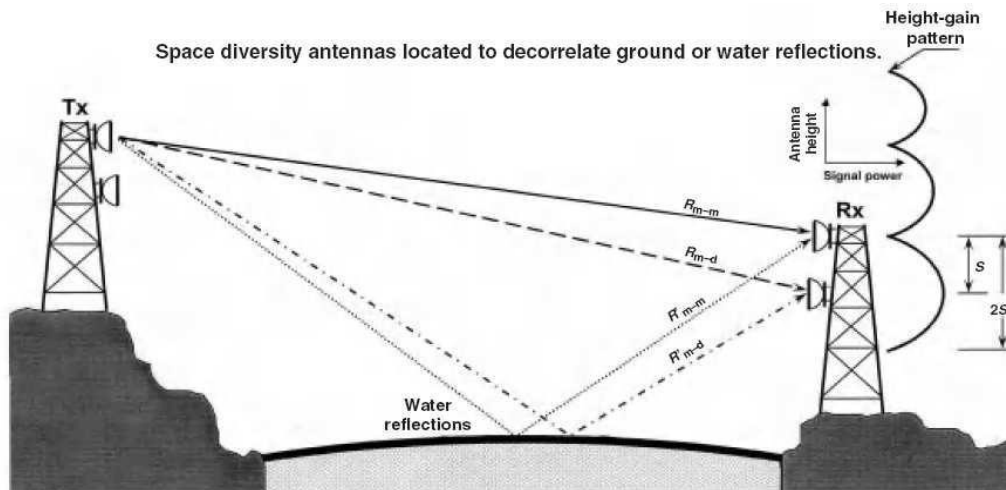
In many cases it is prohibited by national licensing authorities. It also should be appreciated that it will be difficult to get the desired frequency spacing. Frequency diversity offers an improvement factor to the propagation part of the link non-availability. According to the Vigants (1981) model, frequency diversity improvement factor is given by:

$$I_{FD} = 80/fd \times \Delta f/f \times 10^{CFM/10} \quad (1)$$

where  $I_{FD}$  = Frequency diversity improvement factor;  $\Delta f$  = Frequency separation (GHz);

$d$  = hop distance (km);  $f$  = Carrier frequency (GHz) and CFM = Composite fade margin (dB).

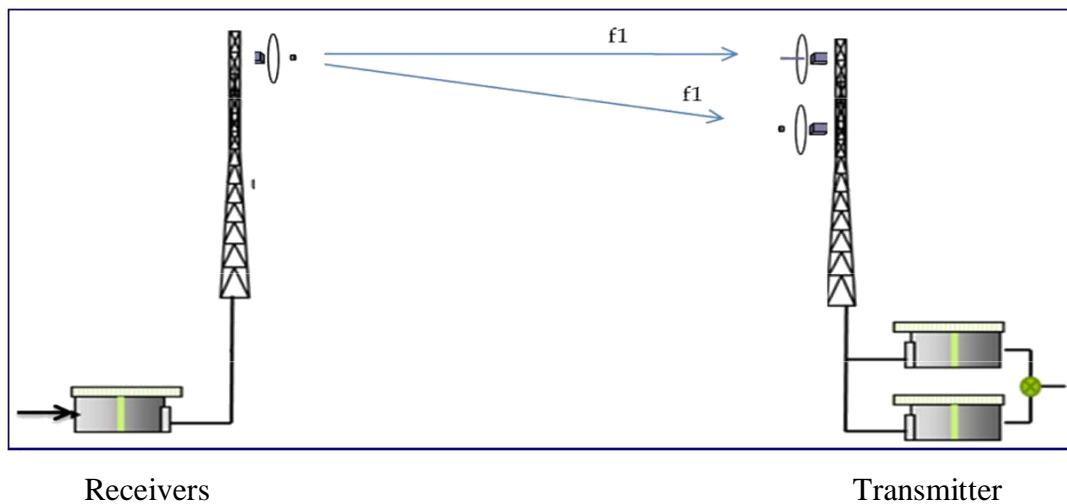
According to Lemieux et al (1993), the major constraint of frequency diversity technique can be resolved using the space diversity technique.



**Figure 2: Space diversity Antenna (Hartman and Smith, 2007).**

For paths with significant surface reflections, two vertically spaced receive antennas (space diversity) can be used to mitigate the effects of the reflected signal (Figure 2). Lemieux et al (1993) defined space diversity as the method of transmission or reception, or both, in which the effects of fading are minimized by the simultaneous use of two or more physically separated antennas, ideally separated by one half or more wavelengths. Putting it differently, Lehpamer (2002) viewed Space diversity as the simultaneous transmission of the same signal over a radio channel by using two or more antennas for reception and/or transmission. Space diversity is the most commonly used diversity option against multipath fading. It is commonly used on long paths, shorter paths and in poor propagation areas and over water paths to protect against surface reflection.

Space diversity is very spectrum efficient and provides excellent performance against multipath fading. The concept of space diversity is to separate the two antennas in the vertical plane such that when there is phase cancellation on the main path due to multipath fading, the diversity path is not affected due to the extra path length (Lemieux, et al, 1993).



**Figure 3: Space diversity techniques (Das, 2008).**

In space diversity, same frequency is used, but two receive antennas separated vertically on the same tower receive the information over two different physical paths separated as in space (Figure 3).

Xexian and Matti (2002) further explained that, space diversity is widely used because it is easy to implement and it is cost effective and very simple. This technique has a single transmitting but multiple receiving antennas. The receiving antennas should be at enough distance so that the multiple fading in the diversity will be uncorrelated. There should be a balanced average power between channels and the correlation coefficient should be very low to achieve a good diversity gain.

The space diversity arrangement can also provide full equipment redundancy (when automatically-switched standby transmitters are used), but does not provide a separate end to end operational path. Space diversity requires additional antennas as compared to frequency diversity arrangement. However, it provides efficient spectrum usage and good diversity protection in many cases, substantially greater than obtainable for frequency diversity, particularly when the latter is using frequency channels with limited spacing between them (Lehpamer, 2010).

Vigants (1971) in his works on microwave radio obstruction fading developed an equation for space diversity improvement factor. The improvement factor was given as:

$$I_{SD} = \frac{7.0 \times 10^{-5} \times f \times S^2 v^2 \times 10^{CFM/10}}{d} \quad (2)$$

where  $I_{SD}$  = Space diversity improvement factor;  $f$  = Frequency (GHz);  $S$  = Vertical antenna spacing (m); CFM = Composite Fade Margin (dB);  $V$  = Relative voltage gain factor and  $d$  = hop distance (km).

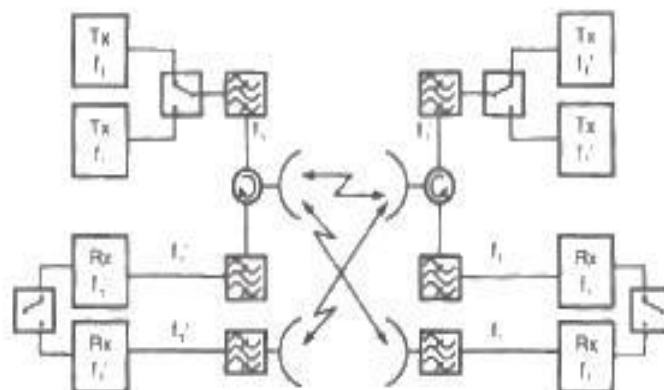
CFM is the composite fade margin in decibel (in space diversity systems, fade margins are computed for both antennas). The larger fade margin value is used to compute the non-diversity reliability, and the smaller fade margin value is used to compute the space diversity improvement. From the works of Vigants (1979), using empirical data and mathematical models, the overall reliability with space diversity can be computed by dividing the non-diversity outage probability by the improvement factor:

$$U_{div} = U_{ndb}/I_{SD} \quad (3)$$

Where  $U_{div}$  = Overall reliability;  $U_{ndb}$  = Non diversity outage probability and  $I_{SD}$  = Improvement factor.

For improved performance on very long or difficult paths, frequency diversity and space diversity can be combined, this is called hybrid diversity. Hybrid diversity is the most effective of all diversity arrangements and is preferred in difficult propagation areas, such as those covering very long distances or transmitting over water (Lehpamer, 2010).

The hybrid diversity technique is implemented by transmitting the transmit signal from the second frequency diversity path on the lower antenna at one end. The arrangement is shown in Figure 4. Hybrid diversity technique combines the benefits of both frequency diversity and space diversity. With frequency diversity, improvement in system performance is obtained by simultaneously transmitting the same information signal on two independent radio frequencies.



**Figure 4: Block diagram of hybrid diversity technique with three antennas (Freeman, 2007).**

The effects of multipath fading and atmospheric attenuation are mitigated by their differential and uncorrelated effect on radio to dynamically select the better signal. This technique is able to combine frequency diversity with space diversity to obtain even greater improvement in system availability. With Hybrid configuration, the system can automatically detect, switch and recover following any equipment failure, all in much less than a second to ensure minimal loss of traffic (Seybold, 2005).

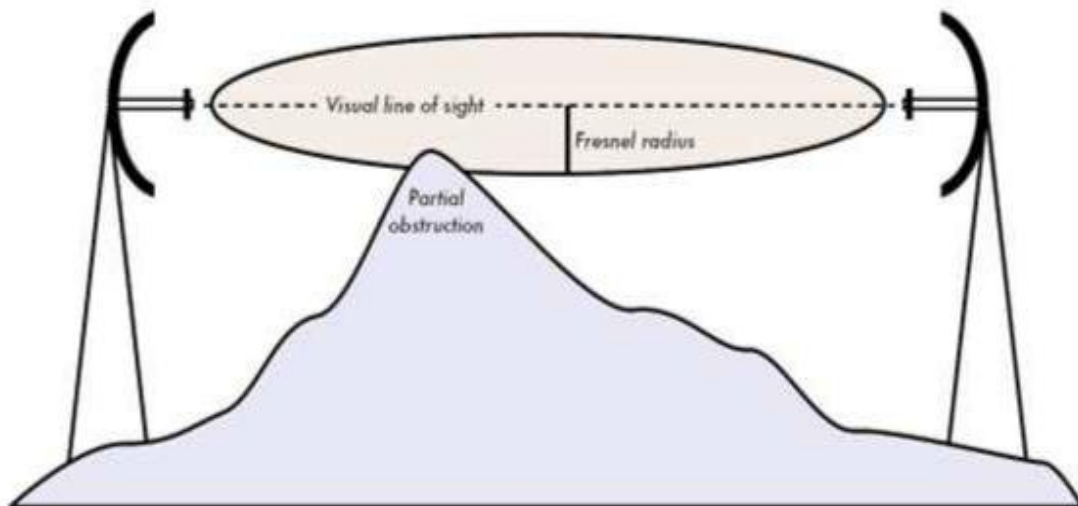
Hybrid diversity would also increase the signal-to-noise ratio (SNR) or the power of received signal. Lehpamer (2010) posits that creating “RF line-of-sight” for a microwave path requires more clearance over path obstructions than is required to establish a visual “line-of-sight.” The extra clearance is needed to establish an unobstructed propagation path boundary for the transmitted signal, based on its wavelength. These boundaries are referred to as “Fresnel zones” which are concentric areas surrounding the direct path of the signal beam between the two antennas.

### **The Fresnel Zones**

While classic path loss models alone can form the basis of correct analysis and prediction for microwave radio link performance, it only relies on descriptions of terrain and other geographical parameters which are quite important. Thus, to effectively predict microwave link performance, it is appropriate to have a visual description of the terrain, distance between transmit and receiving stations and other geographical parameters.

Freeman (2007) opined that to establish “RF line-of -sight,” it is necessary to have a clearance above ground of at least 60% of the radius of the first Fresnel zone. Failure to do so will result in additional signal loss caused by diffraction, the amount of loss will depend on the degree of Fresnel zone encroachment. Although the concern is primarily with clearing 60% of the first Fresnel zone radius, to avoid signal diffraction loss, it is important to realize that Fresnel zones are infinite in number. Each succeeding Fresnel zone has an exact  $\frac{1}{2}$  wavelength relationship to the previous one, and the distance separating each Fresnel zone diminishes as the Fresnel zone number increases (Freeman, 2007) (figure 5).

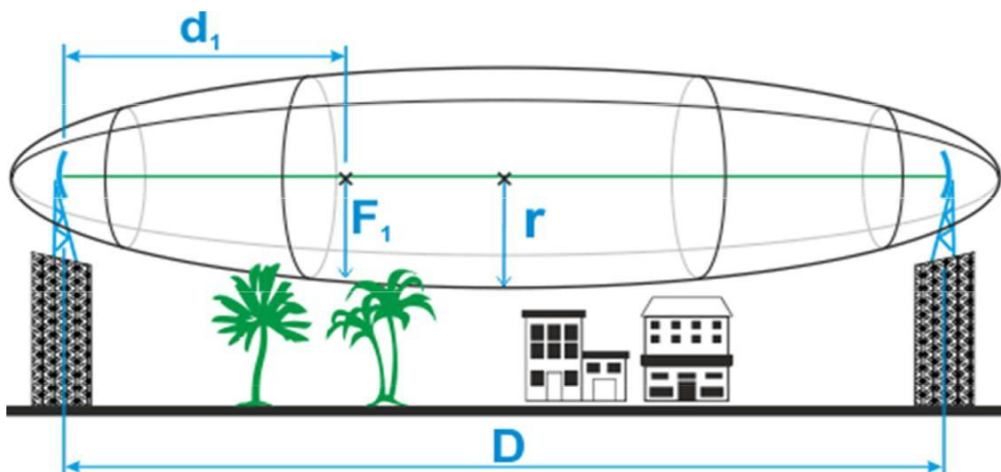




**Figure 5: The Fresnel zone is partially blocked on this link, although the visual line of sight appears clear (Mark and Zhuang, 2002).**

For now, focus is simply on the definition of the 1st Fresnel zone boundary, which is described as follows:

A reflected path length that is exactly  $\frac{1}{2}$  wavelengths longer than the previous one defines the succeeding Fresnel zone boundaries.



**Figure 6: The Fresnel zone calculation: Microwave Transmission Network (Lehpamer, 2010).**

The Fresnel Zone is important to the integrity of the RF link because it defines a volume around the LOS that must be clear of any obstacle for the maximum power to reach the receiving antenna. The First Fresnel Zone is an ellipsoid-shaped volume around the Line-of-Sight path between transmitter and receiver (see figure 6).



Therefore, the boundary for any Fresnel zone radius can be calculated directly using the following formula:

$$F_1 = \sqrt{\lambda \frac{d_1 \cdot d_2}{d_1 + d_2}} \quad (4)$$

where  $F_1$  = Fresnel Zone radius in metres;  $d_1$  = Distance of P from one end in metres;  $d_2$  = The distance of P from the other end in metres and  $\lambda$  = Wavelength of the transmitted signal in metres.

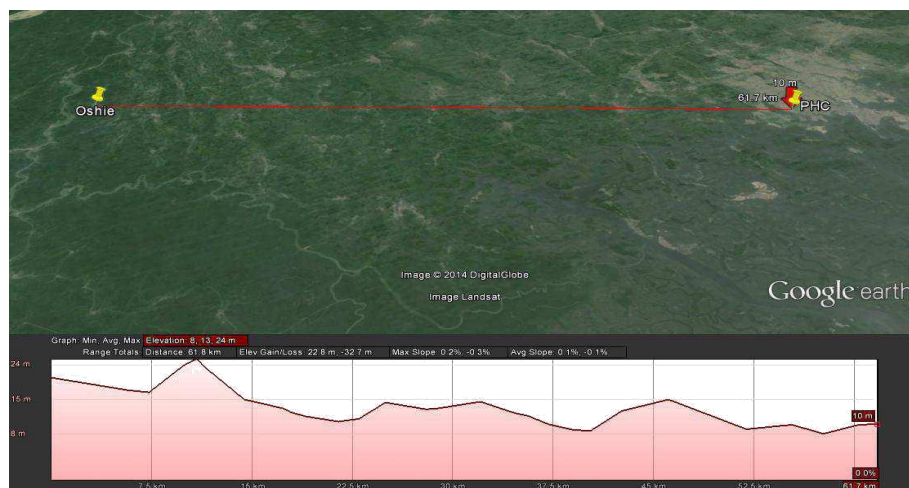
For practical applications, it is often useful to know the maximum radius of the first Fresnel zone. The above formula can be simplified for calculation of the first Fresnel zone:

$$r = 8.657 \cdot \sqrt{(D/f)} \text{ m} \quad (5)$$

where  $r$  = First Fresnel zone radius in metre;  $D$  = Distance between two antenna (in km) and  $f$  = Frequency (in GHz) that is being transmitted.

### Link Performance and Configuration

In the study of Oshie-Port Harcourt, Niger Delta Region, Nigeria microwave radio link (figure 7), detailed measurements and comparison of the different microwave radio link configurations for non-protected, space diversity, frequency diversity and a hybrid diversity model of microwave link were examined and results obtained and evaluated to determine the best predictor of radio link performance. The study also illustrates how Pathloss<sup>®</sup> exponents can be used to determine the microwave link budget and availability predictions of a radio transmission link.



**Figure 7: Oshie-Port Harcourt Microwave Link Topography and Elevation Profile (Pathloss IV, 2014).**

The main objective of this work was to develop an appropriate diversity technique to predict microwave radio link performance, authenticated using Barnett – Vigrant mathematical model. Tables 1 to 5, presents real life performances of the hybrid diversity models for selected NAOC (RSL = -43.50dBm, FM = 33.16dB, FSL = 143.53dB), SPDC (RSL = -45.80dBm, FM = 40.02dB, FSL = 141.80dB), TOTAL (RSL = -42.95dBm, FM = 38.60dB, FSL = 141.13dB) and NLNG (RSL = -43.50dBm, FM = 38.52dB, FSL = 135.50dB) microwave radio links respectively. Analysis of these microwave radio links' performances tabulated in tables 1 to 4 shows that the hybrid diversity techniques provides better free space loss, receive signal level and fade margin values when compared to that of space diversity, frequency diversity and non-protected radio link.

### Hybrid diversity techniques field results

**Table 1: Field measurement results for hybrid diversity microwave link.**

Description	Hybrid diversity Phc-Oshi (NAOC)	Hybrid diversity Phc-Bonny (SPDC)	Hybrid diversity Phc-Onne (Total)	Hybrid diversity Phc-Bonny (NLNG)
Latitude	05 06 06.04 N	04 45 37.00 N	04 48 53.00 N	04 47 40.00 N
	006 30 17.06 E	007 01 41.00E	007 01 48.00 E	007 02 19.00 E
Longitude	04 48 10.17N	04 26 06.31N	04 41 39.00N	04 23 25.00 N
	006 58 26.74E	007 09 35.06E	007 10 28.00E	007 10 45.00 E
Frequency(GHz)	6.5	6.5	6.5	7.275
Polarization	Vertical / Horizontal	Vertical / Horizontal	Vertical/ Horizontal	Vertical/ Horizontal
$G_{(Tx)}$ dBi	35.9	35.9	35.30	36.4
$G_{(Rx)}$ dBi	35.9	35.9	35.30	36.4
$TLL_{(Rx)}$ dB	3	3	3	3
$TLL_{(Tx)}$ dB	3	3	3	3
$P_T$ (dB)	27.5	23.0	23.0	25.5
RSL (dBm)	-43.50	-45.8	-42.95	-43.50
D (km)	61.66	38.30	20.48	47.33
Fade Margin (dB)	33.16	40.02	38.60	38.52
FSL (dB)	143.53	141.80	141.13	135.50
Signal outage(secs)	0.04sec	0.03sec	0.03sec	0.01sec
% Reliability	99.99	99.98	99.99	99.99

## Space diversity techniques field results

Table 2: Field measurement results for space diversity microwave link.

Description	Space diversity Phc-Oshi (NAOC)	Space diversity Phc-Bonny (SPDC)	Space diversity Phc-Onne (TOTAL)	Space diversity Phc-Bonny (NLNG)
Latitude	05 06 06.04 N	04 45 37.00 N	04 48 53.00 N	04 47 40.00 N
Longitude	006 30 17.06 E	007 01 41.00E	007 01 48.00 E	007 02 19.00 E
Frequency(GHz)	6.5	6.5	6.5	7.275
Polarization	Vertical Horizontal	Vertical /Horizontal	Vertical Horizontal	Vertical/ Horizontal
$G_{(Tx)}$ dBi	35.9	35.3	35.30	36.4
$G_{(Rx)}$ dBi	35.9	35.3	35.30	36.4
$TLL_{(Rx)}$ dB	3	3	3	3
$TLL_{(Tx)}$ dB	3	3	3	3
$P_T$ (dB)	27.5	26.0	23.0	25.5
RSL (dBm)	-61.21	-61.95	-61.95	-62.37
D (km)	61.66	20.84	20.48	47.33
Fade Margin (dB)	20.50	24.05	24.05	28.02
FSL (dB)	143.53	141.13	141.13	135.50
Signal outage(secs)	0.04sec	0.07sec	0.05sec	0.01sec
% Reliability	99.96	99.98	99.98	99.97

## Frequency diversity techniques field results

Table 3: Field measurement results for frequency diversity microwave link.

Description	Frequency diversity Phc-Oshi (NAOC)	Frequency diversity Phc- Bonny (SPDC)	Frequency diversity Phc- Onne (TOTAL)	Frequency diversity Phc- Bonny (NLNG)
Latitude	05 06 06.04 N	04 45 37.00 N	04 48 53.00 N	04 47 40.00 N
Longitude	006 30 17.06 E	007 01 41.00E	007 01 48.00 E	007 02 19.00 E
Frequency(GHz)	6.0	6.0	6.5	7.275
Polarization	Vertical Horizontal	Vertical /Horizontal	Vertical / Horizontal	Vertical/ Horizontal
$G_{(Tx)}$ dBi	35.9	21.5	35.30	26.4
$G_{(Rx)}$ dBi	35.9	21.5	35.30	26.4
$TLL_{(Rx)}$ dB	3	3	3	3
$TLL_{(Tx)}$ dB	3	3	3	3
$P_T$ (dB)	27.5	26.5	23.0	24.5
RSL (dBm)	-71.50	-74.95	-70.95	-62.37
D (km)	61.66	20.84	20.48	47.33
Fade Margin (dB)	9.5	7.50	10.50	23.61
FSL (dB)	143.53	141.13	141.13	135.21
Signal outage (secs)	3.1sec	3.07sec	3.05sec	2.01sec
% Reliability	99.95	99.97	99.96	99.98

### Non-protected radio link field results

**Table 4: Field measurement results for non-protected microwave link.**

Description	Non-protected Phc–Oshi (NAOC)	Non-protected Phc–Bonny (SPDC)	Non-protected Phc–Onne (TOTAL)	Non-protected Phc–Bonny (NLNG)
Latitude	05 06 06.04 N	04 45 37.00 N	04 48 53.00 N	04 47 40.00 N
Longitude	006 30 17.06 E 04 48 10.17N 006 58 26.74E	007 01 41.00E 04 26 06.31N 007 09 35.06E	007 01 48.00 E 04 41 39.00N 007 10 28.00E	007 02 19.00 E 04 23 25.00 N 007 10 45.00 E
Frequency(GHz)	6.5	6.5	6.5	7.275
Polarization	Vertical /Horizontal	Vertical /Horizontal	Vertical /Horizontal	Vertical /Horizontal
$G_{(Tx)}$ dBi	20.4	20.0	21.0	20.40
$G_{(Rx)}$ dBi	20.4	20.0	21.0	20.40
$TLL_{(Rx)}$ dB	3	3	3	3
$TLL_{(Tx)}$ dB	3	3	3	3
$P_T$ (dB)	29	28	27.50	27.0
RSL (dBm)	-85.50	-80.50	-75.50	-76.50
D (km)	61.66	20.84	20.48	47.33
Fade Margin (dB)	3.0	2.2	5.0	5.50
FSL (dB)	143.53	141.13	141.13	135.50
Signal outage(secs)	25.04sec	15.07sec	16.05sec	8.01sec
% Reliability	99.93	99.50	99.65	99.30

### Computation of pathloss exponent from different radio links

Tables 5 to 8 presents the results of measurement obtained using the Barnett-Vigant mathematical model at Pathloss exponent of receive signal level (RSL), free space loss (FSL) and fade margin (FM) respectively for chosen antenna configuration for the selected microwave radio link were also examined.

### Hybrid diversity techniques results

**Table 5: Parameters of Barnett-Vigant model at different Hybrid Diversity Radio links.**

Data	NAOC(Phc – Oshi)	SPDC (Phc–Bonny)	TOTAL (Phc–Onne)	NLNG(Phc–Bonny)
FSL (dB)	143.80	140.48	135.0	133.24
RSL (dB)	-46.31	-45.48	-45.40	-41.94
PT (dB)	25.5	26.0	25	24.50
D (km)	61.66	38.81	20.84	47.33
F (GHz)	6.0	6.5	6.5	7,275
RTPL (dB)	-82.5	-86	-84	80
FM (dB)	36.19	40.52	38.60	38.06
% Reliability	99.99	99.98	99.97	99.99

### Space diversity techniques results

**Table 6: Parameters of Barnett-Vigant model at different Space Diversity Radio links.**

Data	NAOC (Phc – Oshi)	SPDC (Phc-Bonny)	TOTAL (Phc-Onne)	NLNG (Phc – Bonny)
FSL (dB)	143.80	140.48	135.0	133.24
RSL (dB)	-51.51	-57.58	-57.40	-51.94
PT (dB)	27.5	26.0	23.0	24.50
D (km)	61.66	38.30	30.3	47.33
F (GHz)	6.5	6.5	6.5	7,275
RTPL(dB)	-72.5	-82.5	-76.0	-84.0
FM (dB)	20.30	24.72	19.60	26.60
% Reliability	99.94	99.93	99.90	99.92

### Frequency diversity techniques results

**Table 7: Parameters of Barnett-Vigant model at different Frequency Diversity Radio links.**

Data	NAOC (Phc – Oshi)	SPDC (Phc-Bonny)	Total (Phc-Onne)	NLNG (Phc – Bonny)
FSL (dB)	143.80	140.48	135.0	133.24
RSL (dB)	-73.71	-79.48	-67.40	-61.94
PT (dB)	28.50	26.0	23.0	24.50
D (km)	61.66	38.30	20.84	47.33
F (GHz)	6.0	6.0	6.5	7,275
RTPL(dB)	-82	-80	-83	-76
FM	8.29	6.29	9.29	20
% Reliability	99.92	99.91	99.92	99.95

### Non-protected radio link results

**Table 8: Parameters of Barnett-Vigant model at different Non-protected Radio links**

Data	NAOC (Phc – Oshi)	SPDC (Phc-Bonny)	Total (Phc-Onne)	NLNG (Phc – Bonny)
FSL (dB)	144.60	140.60	135.0	133.24
RSL (dB)	-83.50	-78.60	-72.22	-71.44
PT (dB)	29.0	28.0	27.50	27.0
D (km)	61.66	38.81	20.84	47.33
F (GHz)	6.5	6.5	7.0	7,275
RTPL	-81	-80	-76	-76
FM	2.5	1.4	3.78	4.06
% Reliability	99.90	99.91	99.85	99.80

## CONCLUSION

After due comparison and analysis of the Barnett-Vigant model and field results for the various link configurations and diversity techniques, it was found that the Hybrid diversity

configuration technique presented the best link performance results with the highest link availability values (FM = 40.52 dB, RSL = -45.48 dB and FSL = 140.48 for SPDC, Phc – Bonny link) over other known link configuration models. The proposed Hybrid model is flexible, robust and can readily be adapted for other Point-to-Point microwave radio applications within and outside the Niger Delta region of Nigeria. It has also shown significant capability of maintaining good performance. Based on the performance results and data of the different microwave diversity techniques analysed, the hybrid diversity technique is recommended for mission critical microwave system applications where the highest level of availability is required.

## REFERENCE

1. Bhaskar, V. (2009), *Capacity Evaluation for Equal Gain Diversity Schemes over Rayleigh Fading Channels*, International Journal of Electronics and Communications (AEU), 34: 53–67.
2. Das, A and Das, S. (2008), *Microwave Engineering*, 1st edition, McGraw-Hill Higher Education, INC, 204- 210.
3. Freeman, R., (2007), *Radio System Design for Telecommunications*, New York: John Wiley and Sons, Third Edition, 151–153.
4. Hafeth, H. (2006), *An Overview of Diversity Techniques in Wireless*, Helsinki University of Technology, Communications Laboratory, 51–53.
5. Hartman, W. J. and Smith, D. (2007), *Tilting Antennas to Reduce Line-of-Sight Microwave Fading*, Institute of Electrical and Electronics Engineers (IEEE) Transaction on Antennas and Propagation, 23: 250- 258.
6. Lehpamer, H. (2002), *Transmission Systems Design Handbook for Wireless Networks*, 16-23.
7. Lehpamer, H. (2010), *Microwave Transmission Network*, Second Edition, McGraw-Hill Professional, 142–204.
8. Lemieux, J. F., Tanany, M. and Hafez, H. M. (1993), *Experimental Evaluation of Space/Frequency/Polarization Diversity in the Indoor Wireless Channel*, Institute of Electrical and Electronics Engineers (IEEE) Transactions on Vehicular Technology, 40(3): 569-574.
9. Mark, J. W. and Zhuang, W. (2002), *Wireless Communications and Networking, Wireless Access Medium*, Institute of Electrical and Electronics Engineers (IEEE) Journal on Select Areas Communications, 30: 15-20.

10. Nitika, S. and Deepak, S. (2012), *Performance Analysis of Conventional Diversity Combining Schemes in Rayleigh Fading Channel*, International Journal of Advanced Research in Computer Science and Software Engineering, 2(6): 25-35.
11. Vigants, A. (1981), *Microwave Radio Obstruction Fading*, BSTJ, 60(8): 785-801.
12. Seybold, J. S. (2005), *Introduction to RF Propagation*, John Wiley & Sons Inc. Publication, Hoboken, New Jersey, 25-43.