

IMPROVEMENT OF POWER QUALITY USING PMSG AND CASCADED MULTI CELL TRANS QUASI Z-SOURCE INVERTER

C. Nagarajan¹, N. Manikandan*², J. Bharath³ and G. Selvakumar⁴

¹Professor, Department of EEE, Muthayammal College of Engineering, Rasipuram, TN.

^{2,3,4}Students, Department of EEE, Muthayammal College of Engineering, Rasipuram, TN.

Article Received on 07/02/2019

Article Revised on 28/02/2019

Article Accepted on 18/03/2019

***Corresponding Author**

N. Manikandan

Students, Department of
EEE, Muthayammal
College of Engineering,
Rasipuram, TN.

ABSTRACT

This paper describes the improvement of power quality using PMSG and Cascaded Multi Cell Trans Quasi-Z-Source Inverter (CMCTQZSI). Nowadays Permanent magnet synchronous generators are widely used due to the special characteristics of PMSG such as low weight and volume, high performance, and no need of external power

supply for permanent magnet excitation. The PMSG overcome the induction Generator and other generators, owing to it can perform without absorb the grid power. In this paper the Trans quasi Z-source inverter is a present that is a novel topology conjugated from the traditional Z source Inverter. The CMCTQZSI has both buck and boost capabilities as they allow operation of the inverter in the shoot through state. By controlling the shoot through state of IGBTs in the Inverter system minimizes the line harmonics, increase power factor, and to improves boosting ratio and output voltage range a cascaded impression is proposed with adopting multi-winding transformer, which provides an option for this manuscript to use coupled inductor as an alternative of multi-winding transformer and remains the matching voltage gain as cascaded multi cell Trans quasi-Z-source inverter. The parallel correlation of the method is essential to reduce the voltage stresses and to improve the input current gain of the inverter. By using MALAB Simulation, harmonics can be reduced up to 0.82% and also DC side can be boosted up to our required level 200 - 1000 V achievable.

KEYWORDS: Fuzzy System (FS), Permanent Magnet Synchronous Generator (PMSG), Cascaded Multi Cell Trans Quasi-Z-Source Inverter (CMCTQZSI), Wind Energy Transfer System (WETS).

INTRODUCTION

Over the years many renewable energy technologies, such as solar, wind, bio-mass, wave, have advanced significantly from the viewpoint of conversation efficiency and unit cost production. Among those renewable energy sources, wind energy stands as a true alternative to conventional technologies for electricity generation. Unfortunately, most of the systems cannot communicate power at each wind speed particularly low wind speeds which are low in power, but they are entirely frequent. But brand new PMSG technology gives high success power translation that is mechanical force into electrical power. In this analysis to realize the PM generator systems is accessible for this purpose.

In the voltage source and current source inverter, just convert AC to DC only. But we cannot make any other boost operations; we can make only buck operation.^[1,2] The normal Z-Source inverter overcome the above drawback so, both buck and boost operation will done,^[3,4] Compared to Z source inverter, the output voltage of Quasi Z-Source inverter is high.^[5] The TZSI is producing high output voltage compared to QZSI.^[6] Compared to the all other above things the TQZSI is producing higher boost voltage, reduces the switching and harmonic losses.^[7] In TQZSI the shoot through state is used to boost up the magnetic power stored in the DC side inductors L_1 and L_2 without any short circuit in the DC capacitor C_1 and C_2 .

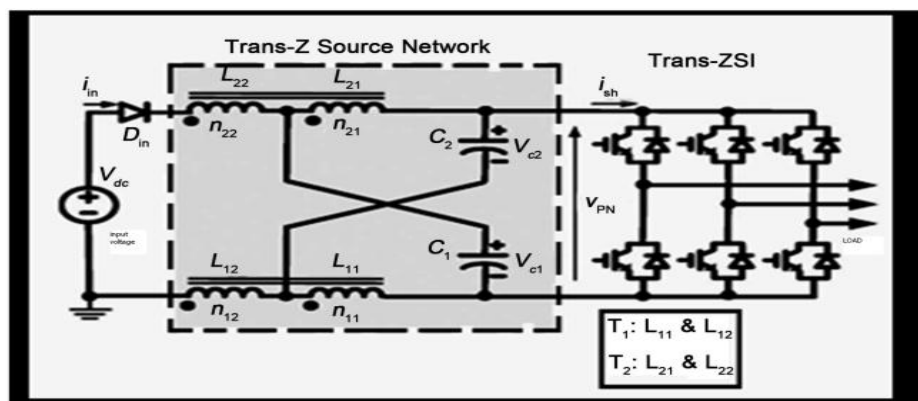

Fig. 1: Conventional Trans Z-Source Inverter.

The fig.1 shows the conversional TZSI where the inductors in the original Z-Source Inverter are replaced by the transformers. It consists of two transformers (T_1 and T_2), two capacitors

(C_1 and C_2), and one diode (D_{in}). The fig. 2 below shows the major construction of Trans quasi impedance network. The conventional TZSI are replaced the inductor by a two winding transformer and removing the corresponding capacitor. So that to construct the trans-quasi-z-source impedance network which is shown in Fig.2. It employs a matchless impedance network fixed between the power source and the circuit for converter that contain a split-inductor $L1$ and $L2$ and capacitors $C1$ and $C2$ connected parallel. The Trans quasi Z-source networks join the inverter to a DC voltage source. The voltage source will be a battery, a diode rectifier or a wind generator. The Trans quasi Z-source networks join the inverter to a DC voltage source. The voltage source will be a battery, a diode rectifier or a wind generator. The TQZSI can boost the input voltage by introducing exceptional shoot through switching state. This state, the TQZSI as instantaneous conduction of the same inverter phase leg.

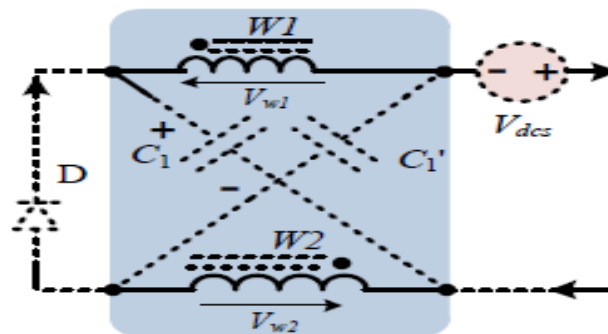

Fig. 2: Proposed Trans Quasi-Z Source Impedance Network.

The most important individuality of the proposed Trans Quasi-ZSI is as follows

- The fundamental X-shape arrangement is retained.
- To increase the boost voltage only two transformers are used, by changing the turn ratio of the transformers very higher boost voltage gain can be obtained.
- Even though the proposed Trans Quasi –ZSI producing higher boost voltage it does not utilize any extra diodes, which reduces its range, price, and loss compared to conventional inverters
- The Trans quasi Z-Source Inverter topologies is for to get better input current shape and place a lower voltage strain on capacitors.

METHODOLOGY

Now-a-days, the PMSG are used for distribution system to improve the moment of power in the system and also to diminish the losses of power in the system. Here a new variable speed

WECS with a PMSG and trans quasi-z-source inverter is proposed. The two main objectives of PMSG are extracting maximum power from wind and feeding the grid with high-quality electricity. Characteristics of TQZS inverter are used for maximum power point tracking control and delivering power to the grid, simultaneously. The variable speed wind turbine driven by PMSG is modeled by using MATLAB/SIMULINK. In general this integration to grid has a back to back converter with DC link. The proposed methodology of this paper is given as a block diagram in fig.3. The block diagram description follows as; It Consists of blades, PMSG, CMCTQZ-source network, CMCTQZ-source inverter and grid. When wind is blowing to the blade, the blade will be rotate. The blade is directly coupled with the shaft of the PMSG. So whenever blade is rotate, the rotor of the PMSG is also rotate, the getting AC power from PMSG is directly fed to the thyristor.

The main purpose of thyristor is changing the AC supply to DC supply the variable speed wind turbine is driven by PMSG. The PMSG is made to run as a synchronous generator by running the machine in negative torque. Since the speed is variable a constant output is not possible and it is oscillating according to the wind. This variable speed AC output is converted to DC by the use of diode rectifier.

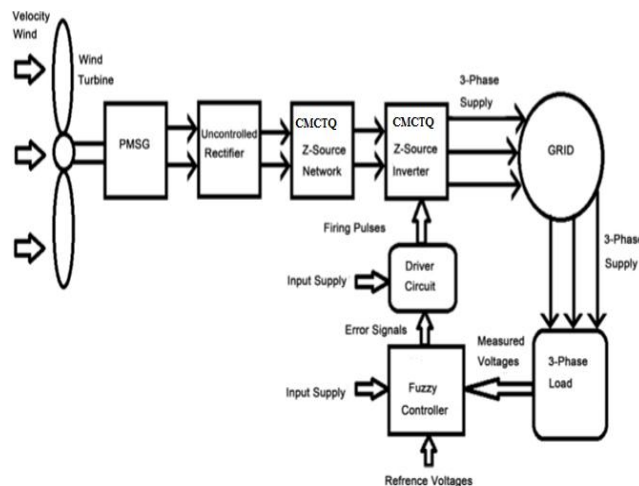

Fig. 3: Proposed Trans Quasi Z Source Inverter System.

This low DC voltage is boosted up without a DC-DC converter by the use of CMCTQZSI, which works on the principle of shoot through process. During shoot through state any two switches of same phase leg is conducting by which DC voltage is boosted. The boost voltage is limited in order to save the switches from the damage as it is made to boost high voltage since the switches will be turned on for a long time. After the duty cycle of shoot through

ratio the CMC inverter act as a normal inverter feeding the variable load. When variable load arrive into act the output from the inverter gets dip. In order to supply the required power to the load and to improve the power quality fuzzy logic control is used. The output is compared with a reference voltage to the variation in inverter output the fuzzy controller generates the pulse signals which control the inverter to generate required output voltage. Therefore we can provide higher output power and the power quality has been improved.

The conventional inverter,^[6] less voltage gain and more harmonics, compared to propose CMCTQZS Inverter, is an option of power conversion concept, while it can have mutually voltage buck and enhance capability. In addition to that, it has the successive power compensation, protection to EMI noise, no in-rush current and misfiring compared to the predictable converter. The multi cell trans-Z-source inverter is shown in fig.4. This inverter has an impedance association on its DC side, which connects the foundation to the inverter. The predictable voltage source inverters have six active vectors and two zero vectors. Conversely, the multi cell trans-Z-source inverter has one extra zero vector (state) for boosting voltage that is called as a shoot-through vector. In this state, load terminals are shorted during mutually the upper and lower devices of in the least one phase leg, any two-phase legs, or all three-phase legs.

FUZZY LOGIC CONTROLLER

A fuzzy logic system (FLS) can be defined as the nonlinear mapping of an input data set to a scalar output data. Fuzzy logic is a form of many valued logic. It deals with understanding that is approximate rather than permanent and truthful. Compared to usual binary sets (somewhere variables may take on true or false values) fuzzy logic variables may possibly restrain a truth value that ranges in degree among 0 and 1. Generally, a fuzzy rule system has four modules; they are Fuzzification, Fuzzy Inference, Rule base and Defuzzification. A FLS consists of four main parts: fuzzifier, rules, inference engine, and defuzzifier. Fuzzification way to technique is to be convert crisp data to Membership Functions (MFs). Fuzzy inference, capital combine membership functions with the control rules to derive the fuzzy output. Rule base means under rule base, rules are constructed for outputs. The rules are in “If Then” format and properly the If side is called the conditions and the Then side is called the conclusion. Defuzzification way to use different methods to calculate each coupled output and put them into a table. Pick up the output from the lookup table based on the error current

input through an application. The classical fuzzy set can be mapped into a function with two elements 0 or 1. Using IF-THEN rule the fuzzy logic controller derive the desired output.

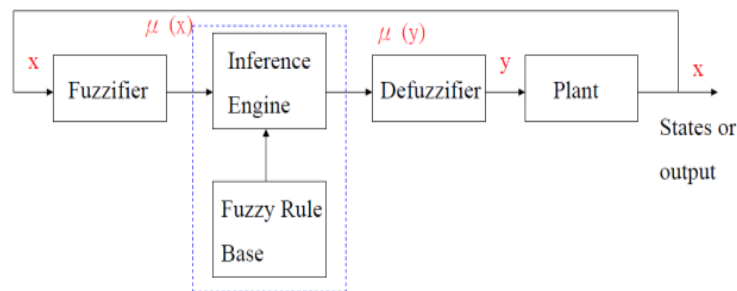

Fig. 5: A Fuzzy Logic System.

In this paper the FLC plays a major role in improving the power quality. Fuzzy logic controller is used to reduce the dip time during variable load and thereby enhancing the power quality. The logic controller works as follows: the variable load comes into act and the FLC gets the input from the grid and it has other input, reference value. The fuzzy controller gives the output by which the firing pulses are generated and the required output for the load is given.

SIMULATION MODELS AND INFERENCE

The Proposed Method has implemented in MATLAB 2009 and executed for maximum constant boost voltage of TQZSI. Using MATLAB/SIMULINK the PMSG is modeled and simulated with an output of 550 V AC as shown in Fig.6. The PMSG output is rectified Fig. 7, which converts the AC voltage into DC voltage. This low DC voltage is fed to the CMCTQZS network. This network steps up the DC voltage according to the boosting factor. Here the boosting voltage is near to 950. The DC-DC conversion is done without a chopper or a boost converter Figure 8, that the boosted DC voltage convert into required AC voltage 440 v refer Figure 9. The line voltage and Line current Figure 10 and Figure 11 and RMS voltage, phase voltage has been verified using Figure 12 and Figure 13. By using Mat-lab Simulink modeling fuzzy system the harmonics level is reduced up to 0.82% refer Fig.14 and Fig.15.

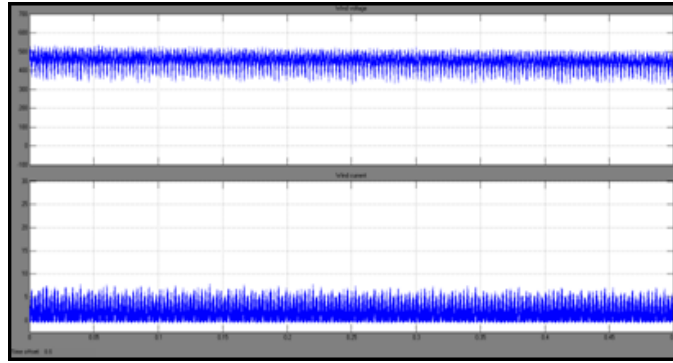

Fig. 6: PMSG Voltage and Current.

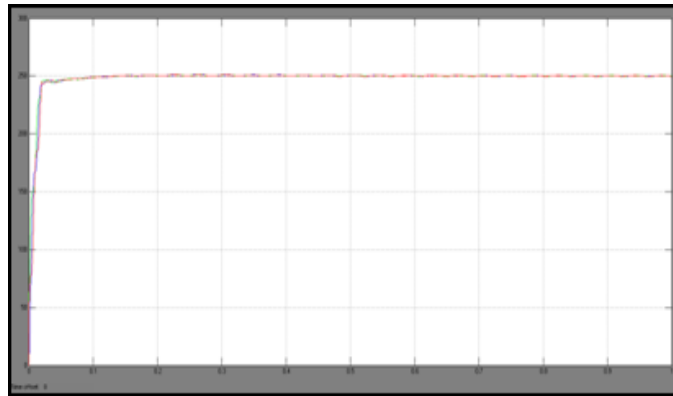

Fig. 7: Rectified Output.

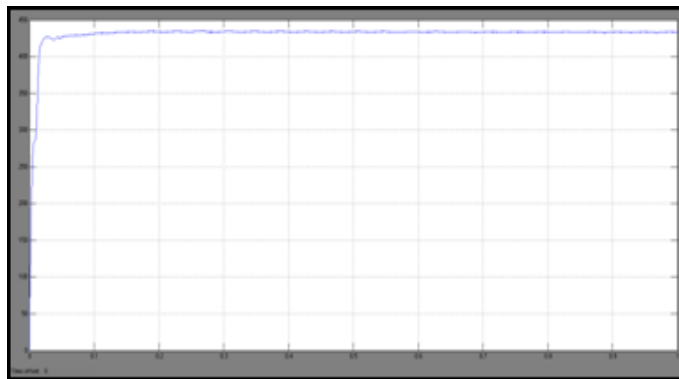

Fig. 8: Line Current.

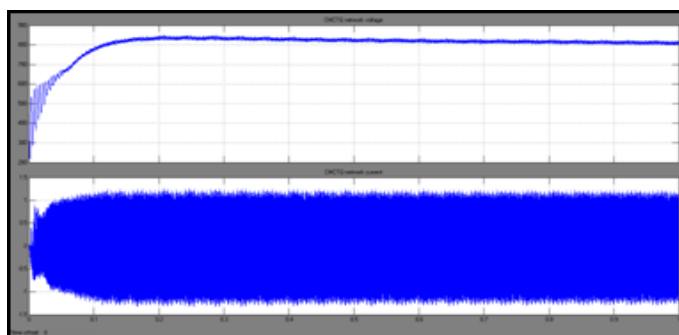

Fig. 9: CMCTQ Voltage And Current.

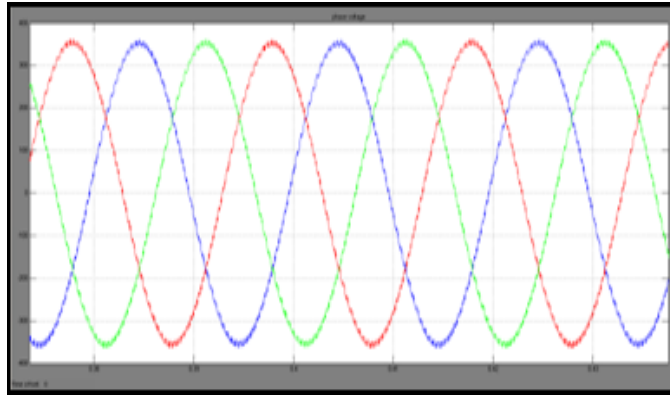

Fig. 10: Phase Voltage.

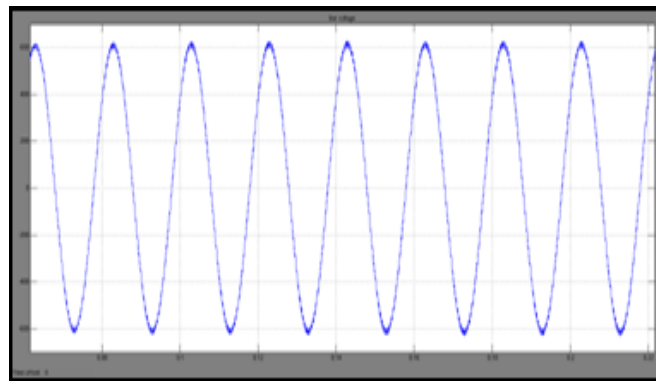

Fig. 11: Line Voltage.

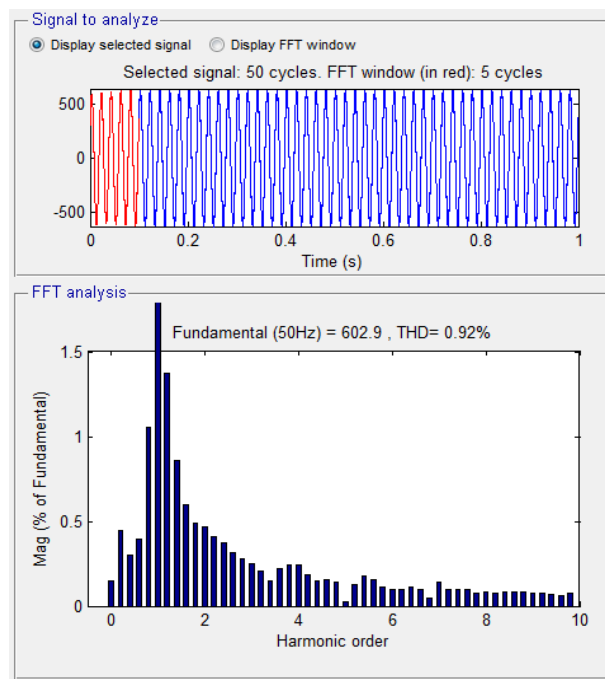

Fig. 12: Phase Harmonics.

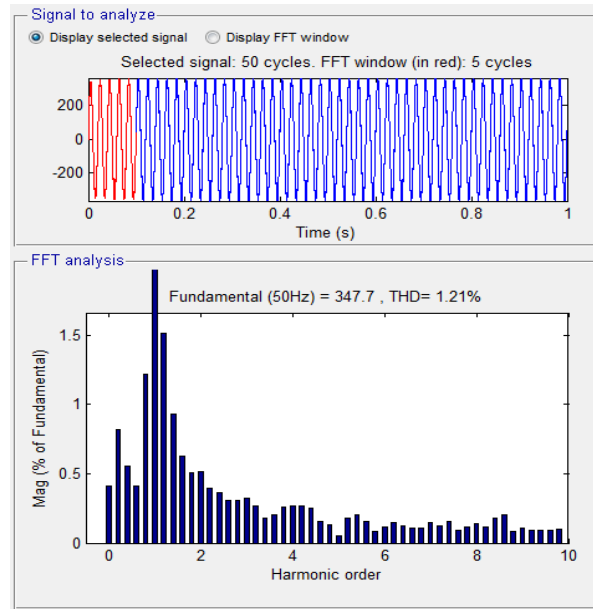

Fig. 13: Line Harmonics.

CONCLUSION

In this paper a generic cascaded multicell Trans Quasi $-Z$ source inverter is proposed. By using coupled transformers with low turns ratio, the proposed inverter divides the instantaneous current stress among the windings. For 120 V AC wind turbine output the proposed network boost up the DC voltage after rectification up to 900 V DC which can be inverted to supply the variable load. The power quality issues for variable load are overcome by using fuzzy logic controller, by which the power quality is improved. The phase voltage harmonics is reduced to 0.82% and the line voltage harmonics was reduced to 0.92%. The TQZSI inherits all the advantages of the ZSI and features its unique merits. The performance of the proposed inverter has been verified using MATLAB/SIMULINK.

REFERENCES

1. E.Rajendran, Dr.C.Kumar, "Power quality improvement for wind energy conversion system using PMSG and Z-source inverter", *International Journal of Engineering Science and Technology*, p-ISSN: 2278-9510, 2013; 5-04S.
2. C.Nagarajan and M.Madheswaran, 'Experimental verification and stability state space analysis of CLL-T Series Parallel Resonant Converter with fuzzy controller' - *Journal of Electrical Engineering*, 2012; 63(6): 365-372.
3. R.Raja and C.Nagarajan, "Performance Analysis of LCL-T Filter Based 2 Stage Single Phase Grid Connected Module with ANN Controller using PV Panel," *Current Signal Transduction Therapy*, 2018; 13(2): 159-167.

4. C.Nagarajan and M.Madheswaran, "Performance Analysis of LCL-T Resonant Converter with Fuzzy/PID Using State Space Analysis" *Springer, Electrical Engineering*, 2011; 93(3): 167-178.
5. E.Geetha, C. Nagarajan, "Stochastic Rule Control Algorithm Based Enlistment of Induction Motor Parameters Monitoring in IoT Applications," *Wireless Personal Communications*, 2018; 102(4): 3629–3645.
6. M.Madheswaran, C.Nagarajan, "DSP Based Fuzzy Controller for Series Parallel Resonant converter", *Frontiers of Electrical and Electronic Engineering*, 2012; 7(4): 438-446.
7. C.Nagarajan, "Single-Stage High-Frequency Resonant AC Converter Using Fuzzy Logic and Artificial Neural networks", *Conference on Emerging Devices and Smart Systems (ICEDSS), 2nd and 3rd March* organized by mahendra Engineering College, Mallasamudram, 2018; 30-37.
8. E Geetha, C Nagarajan, "Induction Motor Fault Detection and Classification Using Current Signature Analysis Technique", *Conference on Emerging Devices and Smart Systems (ICEDSS), 2nd and 3rd March*, organized by mahendra Engineering College, Mallasamudram, 2018; 48-52.
9. GS SatheeshKumar, C Nagarajan, ST Selvi, "A Virtual Impedance Based Analysis of Dynamic Stability in a Micro-Grid System", *Conference on Emerging Devices and Smart Systems (ICEDSS), 2nd and 3rd March* organized by mahendra Engineering College, Mallasamudram, 2018; 38-41.
10. CS Lakshmi, C Nagarajan, "Neural Controlled Multi-Level Inverter Based DVR for Power Quality Improvement", *Conference on Emerging Devices and Smart Systems (ICEDSS), 2nd and 3rd March*, organized by mahendra Engineering College, Mallasamudram, 2018; 42-47.
11. S Thirunavukkarasu, C Nagarajan, "Performance Analysis of BLDC Motor Drive for Feed Drives", *Conference on Emerging Devices and Smart Systems (ICEDSS), 2nd and 3rd March*, organized by mahendra Engineering College, Mallasamudram, 2018; 67-70.
12. JP Daniel, C Nagarajan, "Hybrid Filter for Distorted Voltage Source in Microgrids", *Conference on Emerging Devices and Smart Systems (ICEDSS), 2nd and 3rd March*, organized by mahendra Engineering College, Mallasamudram, 2018; 11-15.
13. K Umadevi, C Nagarajan, "High Gain Ratio Boost-Fly Back DC-DC Converter using Capacitor Coupling", *Conference on Emerging Devices and Smart Systems (ICEDSS), 2nd*

- and 3rd March, organized by mahendra Engineering College, Mallasamudram, 2018; 64-66.
14. C.Nagarajan and M.Madheswaran, "Experimental Study and steady state stability analysis of CLL-T Series Parallel Resonant Converter with Fuzzy controller using State Space Analysis", *Iranian Journal of Electrical and Electronic Engineering*, 2012; 8(3): 259-267.
 15. C. Santhana Lakshmi and C. Nagarajan, "Multiconverter Technology Based Voltage Compensation for Photovoltaic System" *Ecology, Environment and Conservation*, 2017; 23: 226-229.
 16. C.Nagarajan and M.Madheswaran, "Stability Analysis of Series Parallel Resonant Converter with Fuzzy Logic Controller Using State Space Techniques", *Electric Power Components and Systems*, 2011; 39(8): 780-793.
 17. C.Nagarajan, M.Muruganandam and D.Ramasubramanian – 'Analysis and Design of CLL Resonant Converter for Solar Panel - Battery systems- *International Journal of Intelligent systems and Applications*, 2013; 5(1): 52-58.
 18. C.Nagarajan and M.Madheswaran "Experimental Study and Comparative Analysis of CLL-T and LCL-T Series Parallel Resonant Converter with Fuzzy/ PID Controller", *Journal of Electrical Engineering*, 2011; 11(3): 122-129.
 19. C.Nagarajan and M.Madheswaran, "Analysis and Simulation of LCL Series Resonant Full Bridge Converter Using PWM Technique with Load Independent Operation" has been presented in ICTES'08, a IEEE / IET International Conference organized by M.G.R.University, Chennai, 2007; 1: 190-195.
 20. C. Nagarajan, M.Madheswaran and D.Ramasubramanian, "Development of DSP based Robust Control Method for General Resonant Converter Topologies using Transfer Function Model," *Acta Electrotechnica et Informatica Journal*, 2013; 13(2): 18-31.
 21. S.Sathish Kumar and C.Nagarajan, "Performance - Economic and Energy Loss analysis of 80 KWp Grid Connected Roof Top Transformer less Photovoltaic power Plant," *Circuits and Systems*, 2016; 7(6): 662-679.