

SUSTAINABILITY DESIGN ANALYSIS AND TOPOLOGY OPTIMIZATION AIR BLOWER OF INDUSTRIAL MULTIPURPOSE AUTOMATED ROTARY DRYER

***Veronica Ifeoma Henry, Okoh Promise Emeka and Rufus Ogbuka Chime**

Mechanical Engineering Department Institute of Management and Technology Enugu
Nigeria.

Article Received on 04/05/2023

Article Revised on 24/05/2023

Article Accepted on 14/06/2023

***Corresponding Author**

Veronica Ifeoma Henry
Mechanical Engineering
Department Institute of
Management and
Technology Enugu Nigeria.

ABSTRACT

Sustainability has been practical to many fields, as well as engineering, manufacturing and design. Manufacturers are becoming increasingly concerned about the issue of sustainability. For instance, recognition of the relationship between manufacturing operations and the natural environment has become an important factor in the decision making

among industrial societies. Designers and manufacturing decision makers who adopt a sustainability focus and establish a sustainability culture within companies are more likely to be successful in enhancing design and manufacturing. The ability to generate the optimized shape of a part will help us create innovative, validated designs that are free of both performance and manufacturability issues. With Topology Optimization, today, and moving forward, we are able to break the restriction on parameters and fully explore our design space, resulting in more organic and exiting models capable of taking advantage of new manufacturing methods not possible, with parametric optimization. The rotary dryer is a type of industrial dryer employed to reduce or minimize the liquid moisture content of the material it is handling by bringing it contact with a heated chamber this equipment is mainly used for heating, baking or drying of substance and most commonly used for cooking. Our goal is to, develop a low cost, easy-to-use dryer which will be used comfortably, effectively distribute heat which powered by electricity, gas or charcoal. Due to irregular power supply common in developing countries, as well as growing high cost of hydrocarbon, the need arises for the development of a triple energy source that uses electricity, gas and charcoal for

drying. The triplex-powered dryer is a combination of components that make possible the use of alternative heat sources. The element is connected to a thermostat that regulates the rate of heat generation in the system. pipe was connected from the heating drum filled with charcoal via a Blower that blows the hot heat to the cylinder. Computer Aided Design software was used in the design and appropriate material selection was considered for it fabrication i.e. modeling, simulation and sustainability analysis, Topology optimization of the Blower will be carried out. Finally, the prototypes will put in hardware

KEYWORD: CAD, Rotary Dryer, Topology, Optimization, Triple Energy Source, Sustainability.

INTRODUCTION

In recent years, the efforts of manufacturing productions to achieve sustainable manufacture have removed from end-of-pipe solutions to a focus on product lifecycles and incorporated environmental strategies and management systems. Furthermore, efforts are increasingly made to create closed loop, circular production systems and implement new business models. Sustainable manufacturing involves changes that are facilitated by eco-innovation. Integrated initiatives such as closed-loop production can potentially yield higher environmental improvements but require suitably combining a wide range of innovation targets and mechanisms.

Topology is a branch of mathematics that is concerned with the longitudinal properties of geometric figures that do not change when the figure is twisted or stretched in certain ways. In the context of design, a topology study explores design recapitulations of component geometry to satisfy a given optimization goal-such as balancing the weight-to-stiffness ratio, minimizing mass, or minimizing maximum displacement-based on specific loads and geometric constraints, including those imposed by the manufacturing process used. Illustrated in Fig.6-11.

Instead of spending time creating a model, you can use the topology-optimized model as a starting point or reference, enabling you to save time while simultaneously improving performance. Topology studies generate new ideas, explore varying design options, and help refine our designs by letting us know where to add material and where to take it away illustrated in Fig.16. In addition, it helps us create higher fidelity designs, topology studies allow us evaluate other potential production methods. And because the topology-optimized

model is integrated within your design environment, you will quickly be able to finalize your designs with the confidence that there are no performance or manufacturability issues, enabling others in the design-through-manufacturing process to leverage our design data at an earlier stage. Illustrated in Fig:6- 15.

Agricultural products are highly perishable and drying of the product after harvest has been demonstrated as one of the methods to minimize postharvest losses. Different studies have been conducted to evaluate the performance of a rotary dryer for drying of agricultural products.

The rotary dryer is one of the most popular types of convective dryers used in the chemical industry for large- scale production. Apart from being commonly operated in the agricultural, chemical and pharmaceutical industry; rotary dryers have become increasingly important in other sectors because they cover a wide range of material, sizes and shapes. This type of dryer permits easy scale up of pilot dryer to industrial. Drying is the best method of preservation of fermented and unfermented ground cassava, and the rotary dryer was proposed to be the best dryer for drying ground cassava. The rotary dryer is good for continuous operation, and can dry large quantity of ground cassava, it's easy to operate, with low maintenance cost.

Despite the various applications of cassava products, preservation of cassava after harvest before processing into cassava starch is still a problem in Africa. The Cost of rotary dryer is not affordable to farmers in Nigeria and Africa hence the need to make available design equations that can be used to fabricate major parts of the rotary dryer for medium scale and large scale drying can be source locally. and also provide solution to the storage problem of cassava after harvest.

It basically consists of an air inlet blower unit, rotary drum, drying assembly, heating unit, Heating drum, framework, heating chamber, as shown in Fig 1, An electric motor of 3.5 Kw was selected as source of power to the rotary drum while a 2kw electric motor provided power to the air inlet fan assembly. The material to be dried is fed to the high end of the dryer and, by rotation of the dryer, usually assisted by internal shelves of flight, is gradually advanced to the lower end where it is discharged. The source of heat for a rotary dryer is usually the hot air that circulates through the dryer. Discharge mechanisms was very effective and the machine was generally found to be easy to maintain by local artisans due to its simple

design. Electric ovens are the direct fired oven, which effectively distribute heat while being powered by electricity, although this can often result in a higher heating cost for the consumer. Many prefer this type of oven because they tend to use dry heat, which helps prevent the buildup of rust. Electric ovens also feature a thermostat that controls the oven's temperature electronically, and many have top, bottom, or rear grill elements. Electric ovens can take longer to heat, but they are relatively inexpensive in cost compared to other types of ovens charcoal ovens are indirectly fired ovens that use wood fuel for cooking. While the traditional wood-fired oven is like a masonry oven (mud oven), such ovens can also be built out of cobor iron. Wood-fired ovens are distinct from wood-fired stoves that have a hot cooking surface for pots and pans like electric stove. A wood stove may also have an oven separate from the fire chamber. Regardless of material they all have an oven chamber consisting of a floor, a dome and an entry. The wood fired oven has an advantage of the less capital requirement, ease of construction and similarly the wood fired has the disadvantage of longer baking time, the product has not baked uniformly and has the problem of the changing the original taste of the product. Gas oven is one which works by the liquefied petroleum gas for the baking of the bread, cake and biscuit.

The major operational principle of the gas oven is the process of heat transfer. Heat transfer tends to occur whenever there is a temperature difference, and the ways in which heat may be transferred in the gas oven that is convection. Convection is the transfer of energy from one place to another by the motion of a mass of materials between the two points. In a natural convection, the motion of the fluid is entirely as a result of differences in density resulting from temperature differences. Naturally, convection occurs when a solid surface is in contact with a fluid of different temperature from a surface. Density differences provide the force required to move the fluid in the food. In the oven, the fluid involved is the enclosed air and the burner surface, which provides the solid surface.

LITERATURE REVIEW

The origins of topology optimization, date back to the late 1980s. That's when the idea of leveraging computing power to speed the development of structures that are optimized for characteristics such as mass and stiffness first emerged in the world of academia. Building on this work, Altair began commercial development. In 1994 that culminated in the release of Altair OptiStruct™ so innovative that is, was named technology of the year by Industry Week. Back then, we found our early adopters in the automotive industry. These were

followed by progressive design teams in sectors such as aerospace and medical. OptiStruct spread from large, blue-chip organizations to smaller enterprises, who also saw the competitive advantages. Well before the emergence of 3D printing, OptiStruct proved its ability to embrace multiple manufacturing methods: forging, plastic injection molding, welded sheet metal structures, casting, and milling. But we didn't stop there. OptiStruct continued to evolve in terms of capability and usability. Today, OptiStruct can consider a wide range of parameters, including external loads, design space, materials and cost, and functionality that extends to areas such as noise and vibrations, durability, non-linear structures, heat transfer, and dynamics. Putting highly complex simulation within reach of more and more users, Opti Struct can justifiably claim to have changed the way the industry approaches the process of design. It was - and is - a truly disruptive technology.

The history of sustainability traces human-dominated ecological systems from the earliest civilizations to the present time. This history is characterized by the increased regional success of a particular society, followed by crises that were either resolved, producing sustainability, or not, leading to decline. In early human history, the use of fire and desire for specific foods may have altered the natural composition of plant and animal communities. Between 8,000 and 10,000 years ago, agrarian communities emerged which depended largely on their environment and the creation of a "structure of permanence."

The Western industrial revolution of the 18th to 19th centuries tapped into the vast growth potential of the energy in fossil fuels. Coal was used to power ever more efficient engines and later to generate electricity. Modern sanitation systems and advances in medicine protected large populations from disease. In the mid-20th century, a gathering environmental movement pointed out that there were environmental costs associated with the many material benefits that were now being enjoyed. In the late 20th century, environmental problems became global in scale. The 1973 and 1979 energy crises demonstrated the extent to which the global community had become dependent on non-renewable energy resources.

In the 21st century, there is increasing global awareness of the threat posed by the human greenhouse effect, produced largely by forest clearing and the burning of fossil fuels. This requires a shift in the perception and understanding of industrial production and the adoption of a more holistic approach to conducting business (Maxwell *et al.*, 2006). The environmental impact of industrial production has historically been dealt with by dispersing pollution in less harmful or less apparent ways (UNEP and UNIDO, 2004). Driven in part

by stricter environmental regulations, industry has used various control and treatment measures to reduce the amount of emissions and effluents. More recently, its efforts to improve environmental performance have moved towards thinking in terms of lifecycles and integrated environmental strategies and management systems, and companies have also begun to accept larger environmental responsibilities throughout their value chains.

The adoption of more integrated and systematic methods to improve sustainability performance has laid the foundation for new business models or modes of provision which can potentially lead to significant environmental benefits. Efforts to create closed-loop, circular production systems have particularly focused on revitalizing disposed products into new resources for production, for example by establishing eco-industrial parks where economic and environmental synergies between traditionally unrelated industrial producers can be harnessed.

Between 8,000 and 10,000 years ago, agrarian communities emerged which depended largely on their environment and the creation of a "structure of permanence." The Western industrial revolution of the 18th to 19th centuries tapped into the vast growth potential of the energy in fossil fuels. Coal was used to power ever more efficient engines and later to generate electricity. Modern sanitation systems and advances in medicine protected large populations from disease.

As a technological process, perhaps food processing originated as baking of bread in Egypt as early as 4000BC which involved operation such as kneading, mixing leavening and baking. Wine making was known to Romans in 7000BC, this bakers and brewers were the forerunners of current food processing industries. Dehydration and pickling were known to Indians from time immemorial (RAO, 2012).

However, the first industrial food processing operation was canning of food which was invented by Donkin and Hall in England in the year 1812 which was a thermal way of degradation of microorganisms and enzymes that spoils the foods. From then onward, the food technology has undergone several modifications until the development of recent techniques of packing of fruit pulps in the year 1960 the agricultural development process can be seen in different stages the modern food processing is a saga of application of engineering principles to process high volume of raw material to pre servable products.

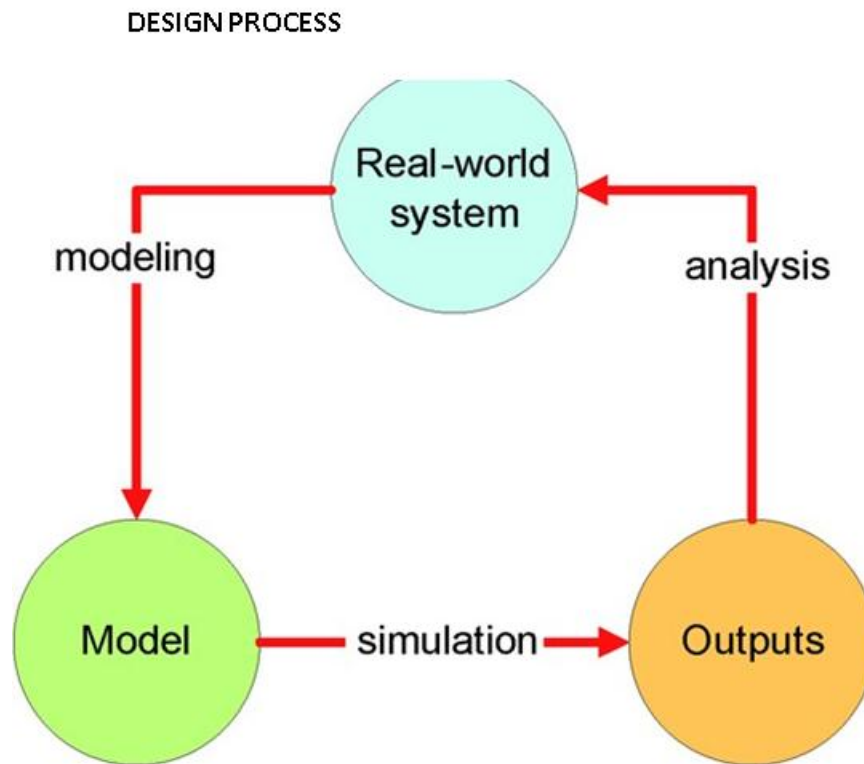
In the mid-20th century, a gathering environmental movement pointed out that there were environmental costs associated with the many material benefits that were now being enjoyed. In the late 20th century, environmental problems became global in scale. The 1973 and 1979 energy crises demonstrated the extent to which the global community had become dependent on non-renewable energy resources. In the 21st century, there is increasing global awareness of the threat posed by the human greenhouse effect, produced largely by forest clearing and the burning of fossil fuels.

Gas oven one of the first recorded uses of a gas stove and oven referenced a dinner party in 1802 hosted by Zachaus Winzler, where all the food was prepared either on a gas stove or in its oven compartment. In 1834, British inventor James Sharp began to commercially produce gas ovens after installing one in his own house. In 1851, the Bower's Registered Gas Stove was displayed at the Great Exhibition. This stove would set the standard and basis for the modern gas oven. Notable improvements to the gas stove since include the addition of the thermostat which assisted in temperature regulation; also an enamel coating was added to the production of gas stoves and ovens in order to help with easier cleaning.

METHODOLOGY

Computer Aided Design

CAD began as an electronic drafting board, a replacement of the traditional paper and pencil drafting method. Over the years it has evolved into a sophisticated surface and solid modeling tool. Not only can products be represented precisely as solid models, factory shop floors can also be modeled and simulated in 3D. It is an indispensable tool to modern engineers. Engineers use CAD to create two- and three-dimensional drawings, such as those for automobile and airplane parts, floor plans, and maps and machine assembly. While it may be faster for an engineer to create an initial drawing by hand, it is much more efficient to change and adjust drawings by computer. In the design stage, drafting and computer graphics techniques are combined to produce models of different parts. ie. Using a computer to perform the six-step 'art-to-part' process: The first two steps, was illustrated in Fig :1-4.



Chime 2020

Performing Simulation Analysis

Following are the steps to perform simulation analysis.

- **Step 1:** Prepare a problem statement.
- **Step 2:** Choose input variables and create entities for the simulation process. There are two types of variables - decision variables and uncontrollable variables. Decision variables are controlled by the programmer, whereas uncontrollable variables are the random variables.
- **Step 3:** Create constraints on the decision variables by assigning it to the simulation process.
- **Step 4:** Determine the output variables.
- **Step 5:** Collect data from the real-life system to input into the simulation.
- **Step 6:** Develop a flowchart showing the progress of the simulation process.
- **Step 7:** Choose an appropriate simulation software to run the model.
- **Step 8:** Verify the simulation model by comparing its result with the real-time system.
- **Step 9:** Perform an experiment on the model by changing the variable values to find the best solution.
- **Step 10:** Finally, apply these

SUSTAINABILITY ANALYSIS AND MODEL OF THE MACHINE

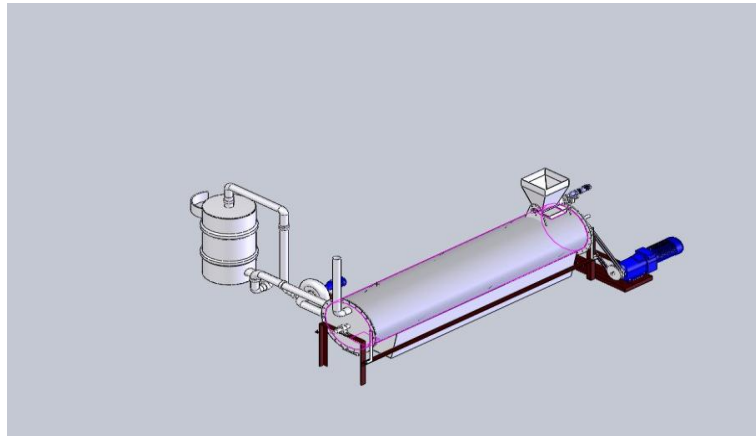


Fig. 1: Final Design.

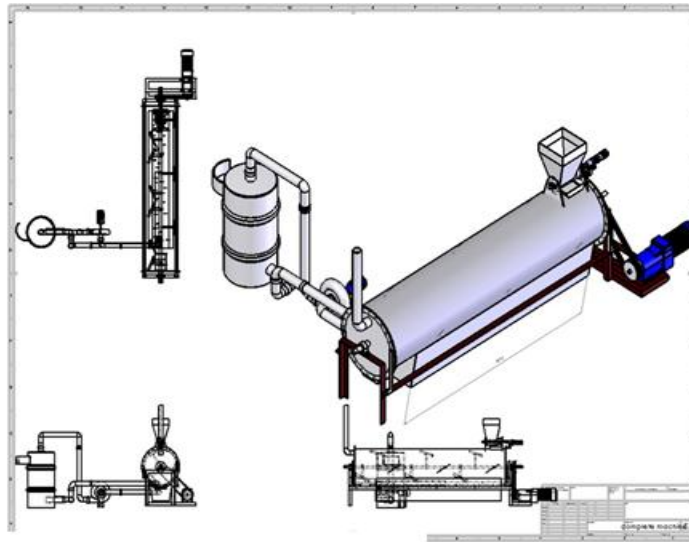


Fig. 2: Multiply Views.

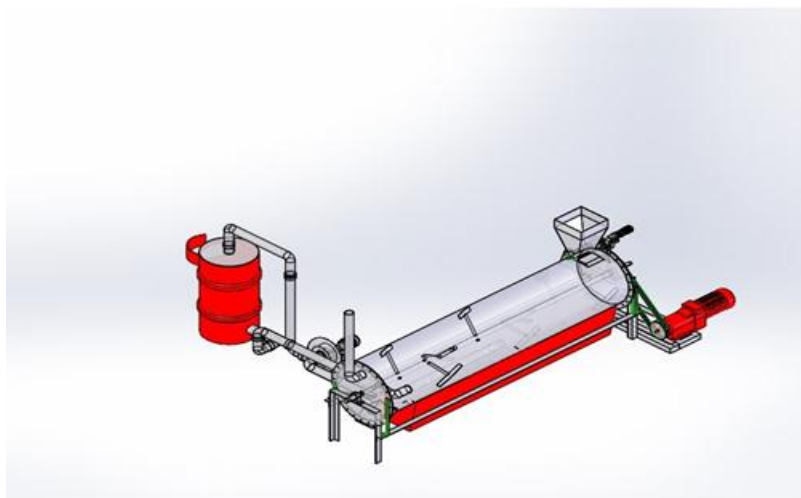
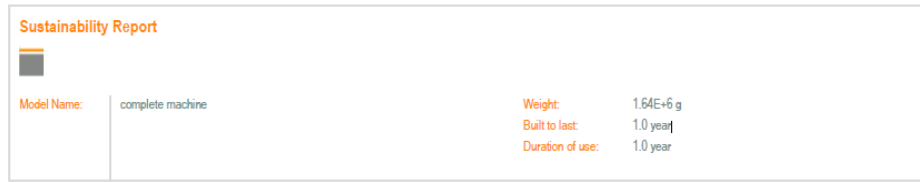


Fig. 3: Sustainability Analysis.



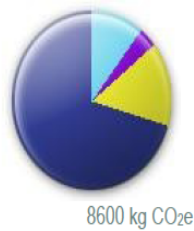
Component Environmental Impact

Top Ten Components Contributing Most to the Four Areas of Environmental Impact

Component	Carbon	Water	Air	Energy
driving gear motor	2500	8.3	13	2.7E+4
hot chamber	920	3.1	4.9	9800
heating chamber	820	2.7	4.4	8800
shaft	760	2.5	4.1	8100
connecting pipe2	440	1.7	2.7	4900

Table 1: Component Environmental Impact-The above illustrated the material selection which provides the most environmentally-friendly impact for the design.

Carbon Footprint



Material:	6100 k
Manufacturing:	1300 k
Use:	0.00 k
Transportation:	320 kg
End of Life:	900 kg

Air Acidification



Material:	23 kg S
Manufacturing:	18 kg S
Use:	0.00 kg
Transportation:	3.3 kg S
End of Life:	0.459 k

Chime et al 2018

Table 2: Illustrated environmental impacts of designs, reduce material and energy usage, and incorporatesustainable design practices which save time and money.

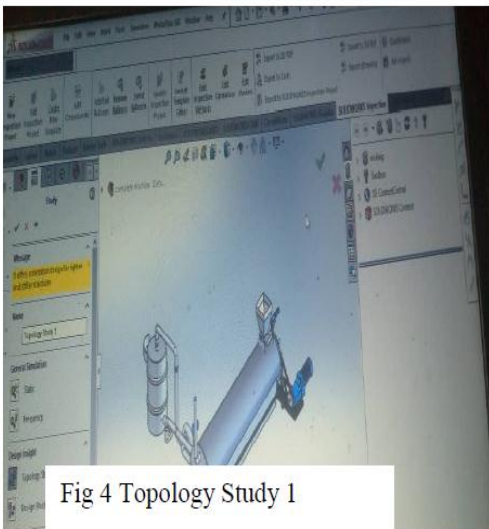


Fig 4 Topology Study 1

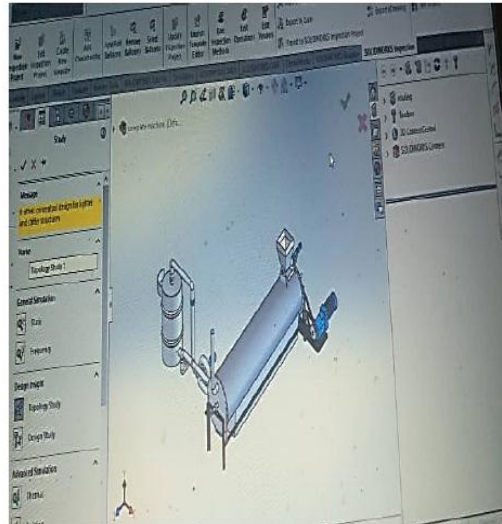


Fig 5 Selection of the Material

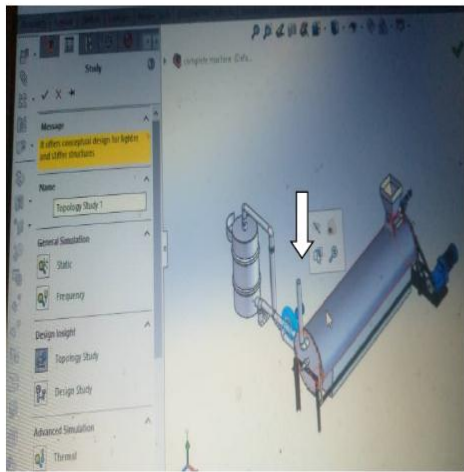


Fig 6 Extract Air Blower Form the Model

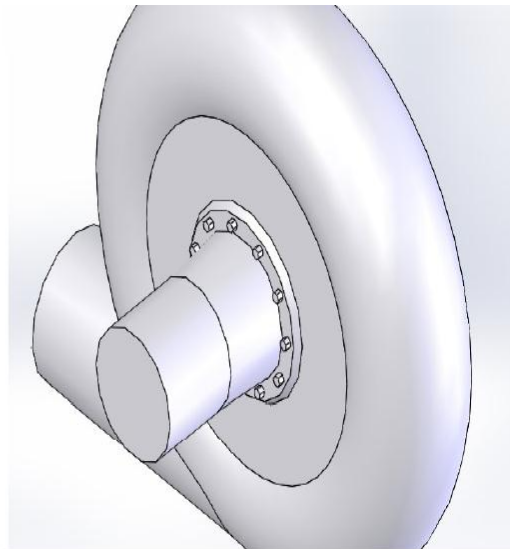


Fig 7 Air Blower

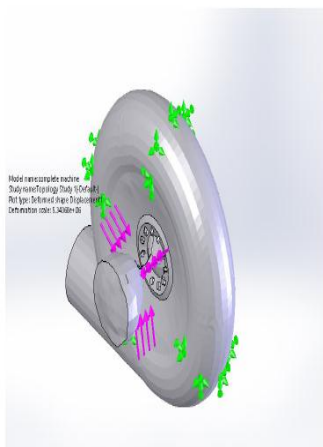


Fig 8 Define the Fixture

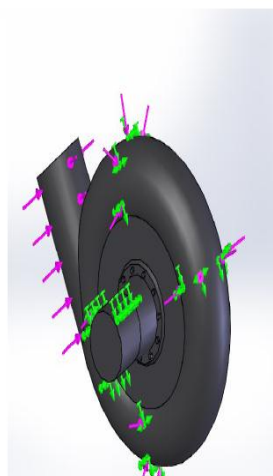


Fig 9 Apply Force

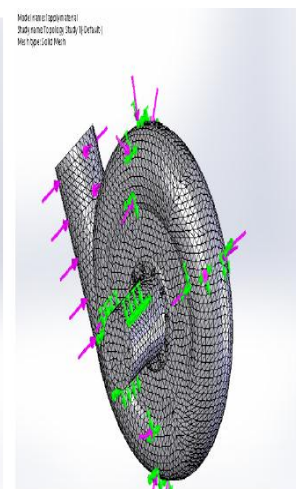


Fig 10 Apply Mesh

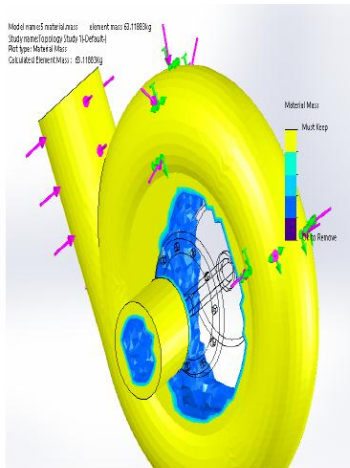


Fig 11 Element Mass 63.1188.3kg

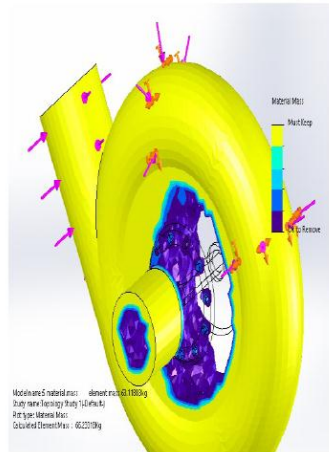
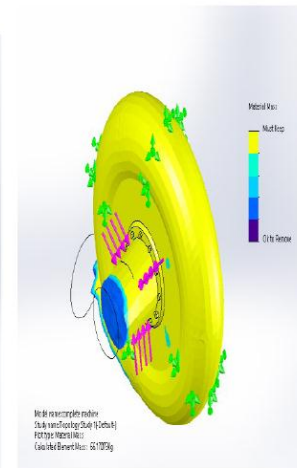
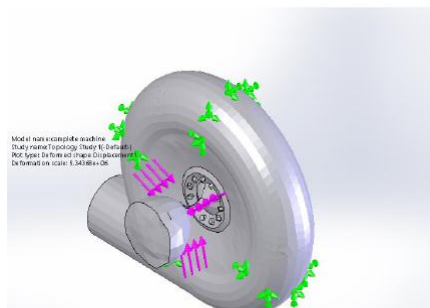
Fig 12 Element Mass
64.85100kgFig 13 Element Mass
66,17073kd

Fig 14 Deformation Scale 5, 3436.8e +06

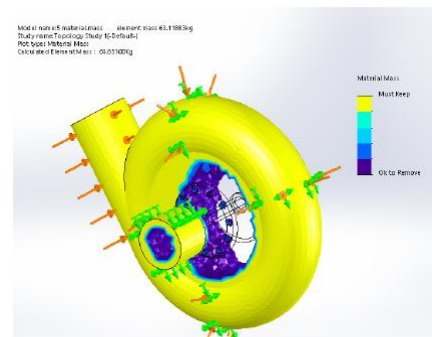


Fig 15 Final Analysis

Performing Topology Optimization

Topology optimization has been something of an exhortation in CAD circles for the last few years, and promises to enable designers to produce lightweight organic forms that have never been seen before.

SOLIDWORKS 2018 includes the addition of topology optimization (<https://www.engineersrule.com/topology-optimization-comes-solidworks/>).

Preparation

Load up SOLIDWORKS 2018, illustrated in fig 4-8

Goals and Constraints

Defining goals and constraints of the Air blower model

The optimization goal and the geometric constraints can be controlled with the Goals and Constraints Property Manager of SolidWorks Simulation, which can drive the mathematical

formulation of the optimization algorithm When the “Best Stiffness to Weight ratio” choice is selected, the algorithm Fig 6- 15 attempts to lower the model's global compliance, which is a measure of its overall flexibility (reciprocal of stiffness). Two restrictions for one optimization target can be defined at the same time in SolidWorks **Simulation**. To obtain a considerable mass savings compared to the baseline design, the option "Best Stiffness to Weight Ratio" with a 30% mass reduction was chosen for the current investigation with this option, the taken into consideration of the blower' illustrate in table 3

Defining the Manufacturing Controls

The optimization study can develop a design that satisfies the optimization goal and any geometric constraints you outline. However, the layout of support blower, can be not possible to create the use of preferred production techniques, such as casting and forging. Applying right geometric controls prevents opportunity of the formation of undercuts and hollow parts. Illustrated in Fig11-13, there are four different types of manufacturing controls in SolidWorks Simulation.

The following are some of them

- De-mold Control Property Manager, this feature can define de-mold controls to make certain that the optimized layout is manufactural and may be extracted from a mold.
- Symmetry Control Property Manager, this feature can make the optimum layout symmetrical around a specific plane. For an optimum arrangement, this feature can also enforce a half, quarter, or eighth planar symmetry.
- Preserved Region Property Manager, this feature can add preserved areas to initial geometry that will not be changed at some point of topology optimization

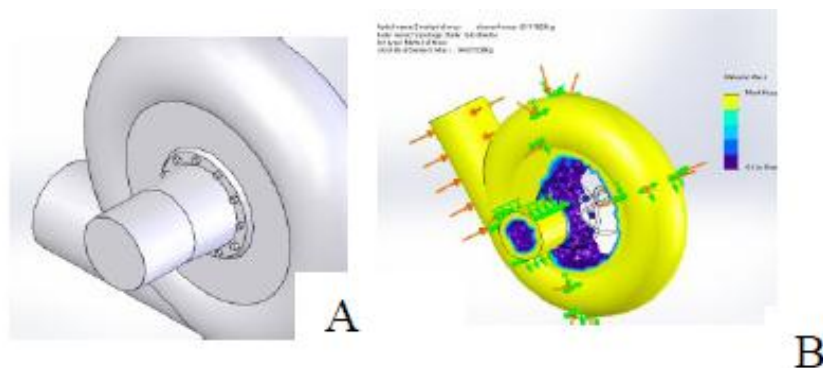


Fig. 16: Illustrations Before and after analysis A-B.

DISCUSSION OF RESULTS

ITERATION [OBJ_FUN [OBJ]OBJ_[OBJ]OBJ_[CON]MAS [VAR]STIFF [VAR]MAS
[VAR]AV_C[VAR]AV_C [VAR]AV_C [VAR]

Table 3: Result.

Norm-Valu	9.44E-06	9.44E-06	9.44E-06	62.7161	9.44E-06	139.3691	0	1.00E-03	5.00E-03
0	9.44E-06	9.44E-06	9.44E-06	62.71614	9.44E-06	62.71614	0	0	0
1	6.67E-06	6.67E-06	6.67E-06	53.09869	6.67E-06	53.09869	0	4.15E-01	1.22E-01
2	4.08E-06	4.08E-06	4.08E-06	51.29698	4.08E-06	51.29698	0	0.636592	7.00E-02
3	2.40E-06	2.40E-06	2.40E-06	50.48891	2.40E-06	50.48891	0	0.698916	7.01E-02
4	1.97E-06	1.97E-06	1.97E-06	53.44022	1.97E-06	53.44022	0	0.219272	2.26E-02
5	1.94E-06	1.94E-06	1.94E-06	54.54744	1.94E-06	54.54744	0	1.42E-02	8.16E-03
6	1.93E-06	1.93E-06	1.93E-06	55.35235	1.93E-06	55.35235	0	5.11E-03	6.26E-03
7	1.92E-06	1.92E-06	1.92E-06	56.32446	1.92E-06	56.32446	0	5.62E-03	7.64E-03
8	1.91E-06	1.91E-06	1.91E-06	57.4042	1.91E-06	57.4042	0	4.80E-03	8.82E-03
9	1.90E-06	1.90E-06	1.90E-06	58.49693	1.90E-06	58.49693	0	3.54E-03	9.22E-03
10	1.90E-06	1.90E-06	1.90E-06	59.57377	1.90E-06	59.57377	0	2.42E-03	9.16E-03
11	1.90E-06	1.90E-06	1.90E-06	60.64865	1.90E-06	60.64865	0	1.67E-03	9.20E-03
12	1.89E-06	1.89E-06	1.89E-06	61.74092	1.89E-06	61.74092	0	1.20E-03	9.49E-03
13	1.89E-06	1.89E-06	1.89E-06	62.47971	1.89E-06	62.47971	0	8.81E-04	1.15E-02
14	1.89E-06	1.89E-06	1.89E-06	62.54265	1.89E-06	62.54265	0	6.00E-04	1.45E-02
15	1.89E-06	1.89E-06	1.89E-06	62.55213	1.89E-06	62.55213	0	4.82E-04	1.62E-02
16	1.89E-06	1.89E-06	1.89E-06	62.55912	1.89E-06	62.55912	0	4.04E-04	1.77E-02
17	1.89E-06	1.89E-06	1.89E-06	62.57615	1.89E-06	62.57615	0	3.27E-04	1.86E-02
18	1.89E-06	1.89E-06	1.89E-06	62.60155	1.89E-06	62.60155	0	2.35E-04	1.75E-02
19	1.89E-06	1.89E-06	1.89E-06	62.64765	1.89E-06	62.64765	0	1.01E-04	1.19E-02
20	1.89E-06	1.89E-06	1.89E-06	62.66708	1.89E-06	62.66708	0	6.32E-06	6.19E-03
21	1.89E-06	1.89E-06	1.89E-06	62.67034	1.89E-06	62.67034	1	1.10E-05	4.97E-03

Topology optimization is a good example of one of those important lessons. For many, it's the relatively recent arrival of commercially viable additive manufacturing that has brought its benefits into focus. This is hardly surprising, as there is a natural symbiosis between the two technologies. Topology optimization has been likened to a free-form 'bionic' process. Similarly, additive manufacturing promises almost unlimited possibilities in terms of shape and form. Structures that are forged and fine-tuned using topology optimization can therefore be executed without having to fit the considerations of 'traditional' manufacturing methodologies. As the world leader in topology optimization, they naturally welcome the many designers who are discovering their solutions via additive manufacturing. Amidst the fresh surge in interest, it's also important to remember that topology optimization has applications that extend much wider, and roots that reach far deeper.

Modelling

Modeling is the process of producing a model; a model is a representation of the construction and working of some system of interest as shown in Fig 1. A model is similar to but simpler than the system it represents. One purpose of a model is to enable the analyst to predict the effect of changes to the system. On the one hand, a model should be a close approximation to the real system and incorporate most of its salient features. On the other hand, it should not be so complex that it is impossible to understand and experiment with it. A good model is a judicious tradeoff between realism and simplicity. Illustrated in Fig.1

Simulation

Involves the generation of an artificial history of the model representing the system and the observation of that artificial history to draw inferences concerning the operating characteristics of the real system. Simulation takes data on the real system. If no data is available, simulation might not be advised.

Sustainability

Simulation technology has been a significant tool for improving manufacturing operations in the past; but its focus has been on lowering costs, improving productivity and quality, and reducing time to market for new products. Sustainable manufacturing includes the integration of processes, decision-making and the environmental concerns of an active industrial system to achieve economic growth, without destroying precious resources or the environment. Sustainability applies to the entire life cycle of a product, selection of materials, extraction of those materials, of parts, assembly methods, retailing, product use, recycling, recovery, and disposal will need to occur if simulation is to be applied successfully to sustainability. illustrate in Fig;3 and Table 1-2

Topology Optimization

In simplest terms, a topology revision utilizes an iterative process to run a design optimization loop to generate the best possible contour based on the loads, constraints, boundary conditions, and manufacturing controls itemized. Using an automatically generated finite element analysis (FEA) mesh of your design space and your inputs of loads, constraints, boundary conditions, and manufacturing controls, the topology optimization seeks a new material layout by redistributing material to satisfy all the structural, mechanical, and manufacturing requirements. It determines how to distribute material by removing the “soft” elements that do not contribute to the stiffness of the component for the particular load

scenario, boundary conditions, and manufacturing controls. For each element, the optimization algorithm couples the material's Young's modulus with a relative mass density factor ranging from 0.0001 (for a void element without any load-carrying capacity) to 1.0 (for a solid element with load-carrying capacity). Elements with low relative mass densities (< 0.3) are considered "soft" elements. These elements do not contribute to the overall stiffness of the component, and they can be safely removed. Elements with high relative mass densities (> 0.7) are considered "solid". These elements contribute the most to the overall stiffness (as a measure of the load-carrying capacity) of the component, and they should remain intact in the final design. The "solid" elements distribute the applied loads more effectively than the "soft" elements. Illustrated in table 3.

You can use topology studies to optimize designs based on three optimization goals:

- Best stiffness-to-weight ratio;
- Minimize maximum displacement;
- Minimize mass with displacement constraint. This process will create a 3D material layout based on the optimization goal and geometric constraints that you define.

This is typically a very organic shape that may be impossible to create using traditional techniques. You can apply a second set of geometric controls related to the planned manufacturing process to prevent the formation of undercuts, hollow parts, shapes with insufficient draft, and other manufacturability issues

CONCLUSION/ RECOMMENDATION

Unless it is topologically optimized, the weight of each part in the assembly may exceed the required weight. The extra weight means too much material is used, the load on the moving parts exceeds the necessary level, energy efficiency is compromised, and the cost of transporting parts is higher. Now, using topology optimization techniques, it is necessary to lightweight components, design durable for any application. To ensure that manufacturing specifications are met, set minimum material thicknesses, and identify exclusion areas, you may easily define targets and apply controls.

Instead of spending time creating a model, you can use the topology-optimized model as a starting point or reference, enabling you to save time while simultaneously improving performance. Topology studies generate new ideas, explore varying design options, and help refine our designs by letting us know where to add material and where to take it away. In

addition, it helps us create higher fidelity designs, topology studies allow us evaluate other potential production methods. A “win-win” outcome is the introduction of environmentally beneficial innovations that also improve the cost and performance of the product when viewed as part of an overall system. Ideally, single design innovation may contribute to achieving several, different types of goals. Reducing the mass of a product can result in

- Energy and material use reduction, which contributes to resource conservation,
- Pollutant emission reduction, which contributes to health and safety.

Making trade-off decisions is the most challenging part of the process because of the need to simultaneously consider so many different criteria.

Base on this discussion the following policy are necessary, efforts should be made to adopt and popularize this our design especially for the benefits of mankind who make up a great percentage of the Nation’s population. If, the use of this design is adopted, the problem in Grain drying and other agricultural processing Equipment will be minimized and hunger and poverty will be eradicated in Nigeria

Future Studies

1st. Steps are being taken to increase the efficiency of the Machine.

2nd. Steps have been taken to increasing the production capacity of the machine.3rd. Steps have been taken to make the machine automated and still make it affordable for Small and Medium Entrepreneurs’ thus reducing production downtime and make it easy to operate.

ACKNOWLEDGEMENT

This Research was Sponsored by Tertiary Education Trust Fund(TETFUND) No6 Zambezi Crescent. Off Agniyi Ironsi Street, Maitama, Abuja, Nigeria Tel: 070 98818818, www.tetfund.gov.ng.

REFERENCES

1. Ángel A. Juan Pérez Computer Modeling & simulation Amit Bandyopadhyay and Kellen D Traxel Invited review article: Metal- additive manufacturing-Modeling strategies for application-optimized designs Additive Manufacturing, 2018; 22: 758-774.
2. Autant-Bernard, C., Fadairo, M. & Massard, N. Knowledge diffusion and innovation policies within the European regions: Challenges based on recent empirical evidence. *Research Policy*, 2013; 42(1): 196-210.

3. <http://dx.doi.org/10.1016/j.respol.2012.07.009>
4. BBC News (August 2008). In depth: "Climate Change." (http://news.bbc.co.uk/2/hi/in_depth/sci_tech/2004/climate_change/default.stm)
5. BBC News (August 2008). In depth: "Climate Change." (http://news.bbc.co.uk/2/hi/in_depth/sci_tech/2004/climate_change/default.stm)
6. BBC News, UK. Retrieved on, 2009-03-14.
7. B .N Ugwu ^{*1}, T .O Chime ², R.O.Chime Review of Orange Juice Extractor Machines by *Advances in Science, Technology and Engineering Systems Journal*, 2020; 5(5): 485-492(2020)
8. Beddoea, R., Costanzaa, R., Farleya, J., Garza, E., Kent, J., Kubiszewski, I., Martinez, L., McCowen, T., Murphy, K., Myers, N., Ogden, Z., Stapleton, K., and Woodward, J. "Overcoming systemic roadblocks to sustainable health". *Proceedings of the National Academy of Sciences*, 2009; 106(28): E80. author reply E81. doi:10.1073/pnas.0902558106. PMC 2710687 Freely accessible. PMID 19584255.
9. Caradonna, Jeremy L. (2014) *Sustainability: A History*. Oxford University Press, ISBN 978-0199372409
10. Clarke, W. C. (1977). "The Structure of Permanence: The Relevance of Self- Subsistence Communities for World Ecosystem Management," in *Subsistence and Survival: Rural Ecology in the Pacific*. Bayliss-Smith, T. and R. Feachem (eds). London: Academic Press, 363–384.
11. Davies, Rotimi Moses, Davies Onome Augustina (2017) Some Engineering Properties of Fish Feed Pellets published by International Journal of Research in Agriculture and Forestry Volume 4, Issue 10, 2017, PP 38-43 ISSN 2394-5907(Print) & ISSN 2394-5915 (Online)
12. D. Higgs Feed Milling Processes, Environment, Canada Vancouver, British Columbia.
13. Evaluation of an Automatic Fish Feeder Journal of Aquaculture Research & Development
14. FAO 1971. The production of fish meal and oil. FAO fisheries technical paper 142.Rome
15. Hilgenkamp, K. Environmental Health: Ecological Perspectives(https://books.google.com/books?id=DuCnxKIDLogC&pg=PA37&lpg=PA37&dq=sanitation+systems+medicine+disease+history&source=web&ots=EFQCzpdpHD&sig=fG96c9PgC6y6vUxG6-PGFDcjbNE&hl=en&sa=X&oi=book_result&resnum=4&ct=result#PPA41,M1).London: Jones & Bartlett. ISBN 978-0-7637-2377-4, 2005.

16. I. O. Ofondu, B. N. Ugwu and R. O. Chime Wooden Refrigeration System By *World Journal of Engineering Research and Technology*, 2018.
17. <https://altair.com/newsroom/executive-insights/Topology-Optimization->
18. https://help.solidworks.com/2018/English/SolidWorks/cworks/hidd_goals_constraints.htm?id=eeda6362756f4ff090ce3a44c7a343fb#Pg0 (accessed Sep. 17, 2021).
19. https://help.solidworks.com/2018/English/SolidWorks/cworks/c_manufacturing_controls_topology.htm?id=1a7fb1812efd482eaa96508182dc6503#Pg0 (accessed Sep. 17, 2021).
20. <https://www.engineersrule.com/performing-topology-optimization-step->
21. www.solidworks.com
22. <https://store.tutorialspoint.com>
23. https://www.unido.org/sites/default/files/200711/37469_eannualreport_0.pdf
24. Introduction to simulation Banks, Carson, Nelson & Nicol *Discrete-Event System Simulation*
25. Jude A. Onuigbo and Rufus O. Chime Innovation in Feed Mixing Machine: Design for Manufacturing in Industry, *World Journal of Engineering Research and Technology WJERT*, 2018.
26. Mergendoller, J. R. Maxwell, N. L., & Bellisimo, Y. The Effectiveness of Problem-Based Instruction: A Comparative Study of Instructional Methods and Student Characteristics. *Interdisciplinary Journal of Problem-Based Learning*, 2006; 1(2). Available at: <https://doi.org/10.7771/1541-5015.1026>.
27. Meadows, D.H., D.L. Meadows, J. Randers, and W. Behrens III. *The Limits to Growth*. New York: Universe Books. ISBN 0-87663-165-0, 1972.
28. Millennium Ecosystem Assessment (2005). *Ecosystems and Human Well-being: Biodiversity Synthesis*.
29. (<http://www.millenniumassessment.org/documents/document.354.aspx.pdf>) World Resources Institute, Washington, DC, 1–85. Retrieved on, 2009-07-08-01.
30. Noha Peter, Zachary Pitts, Spencer Thompson and Ankit Saharan Benchmarking build simulation software for laser powder bed fusion of metals *Additive Manufacturing*, 2020; 2030903-9.
31. Rahman, M.M., Ariffin, A.K., Abdullah, S., Noor, M.M., Bakar, R.A. and Maleque, M.A. Finite element based fatigue life prediction of cylinder head for two-stroke linear engine using stress-life approach. *Journal of Applied Sciences*, 2008; 8(19): 3316-3327.
32. Rahman, M.M., Ariffin, A.K., Jamaludin, N. and Abdullah, S. 2007. Effect of nitriding

- treatment on fatigue life for free piston linear engine component using frequency response method: a finite element approach. *Structural Durability and Health Monitoring*, 3(4): 197-209.
33. Rao, T. S., & Jyoti, A. A. V. Utilisation of Audio-Visual Aids at Government Primary School in Vishakhapattnan District, Andhra Pradesh. *International Journal of Multidisciplinary Educational Research*, 2012; 1: 311-318.
 34. R.O.Chime Ugwu. B.N,Arokwu F.N Design Innovation in MetalFabrication of Industrial Palm Fruit Bunch Stripper Analysis by ://www.casestudiesjournal.com/, 2020.
 35. R.O.Chime et al Innovation In A Water Well Potable Drilling Machine Design Analysis by BEST: *International Journal of Management Information Technology and Engineering (BEST: IJMITE)* www.bestjournals.in, 2020.
 36. R.O.Chime et al Design Innovation In Palm Fruit Bunch Stripper: *A Contribution To Sustainable Development by World Journal of Engineering Research and Technology* www.wjert, 2018.
 37. R.O.Chime, M. A, Yakubu, C.U.Echegi Simulation Modelling Analysis of Shell and Tube Heat Exchanger by *World Journal of Engineering Research and Technology* www.wjert, 2018.
 38. R.O.Chime E.A Agwu Improving Design Management In Palm Kernel Nut Cracking and Separating Machine Analysis by *World Journal of Engineering Research and Technology*, 2021.
 39. R.O.Chime et al Analysis of Garri Frying Machine Manufacturing in Nigeria: Design Innovation published by *Advances in Science, Technology and Engineering*, 2018.
 40. Scholars, R. Stories from the Stone Age. Beyond Productions in association with S4C and S4C International. Australian Broadcasting Corporation. Retrieved on, 2009-04-16.
 41. Shenoy, P.S. Dynamic load analysis and optimization of connecting rod. Master's Thesis. University of Toledo, USA, 2004.
 42. Turner, G.M. "A comparison of the Limits to Growth with 30 years of reality" (PDF). *Global Environmental Change*, 2008; 18(3): 397. doi:10.1016/j.gloenvcha.2008.05.001.
 43. Shenoy, P.S and Fatemi, A. Connecting rod optimization for weight and cost reduction, SAE Technical Paper, Paper No., 2005-01-0987.
 44. W. H. Hasting, Feed Milling Processes, Mt. Vernon, Washington Ogunlela AO* and Adebayo AA Development and Performance, 2016.
 45. World Wide Fund for Nature *Living Planet Report 2008* (http://assets.panda.org/downloads /living_planet_report_2008.pdf). Retrieved on, 2009-

03-29.

46. Wright, R. *A Short History of Progress*. Toronto: Anansi. ISBN 0-88784-706-4, 2004.
47. U.S. Department of Commerce. Carbon Cycle Science <http://www.esrl.noaa.gov/research/themes/carbon/>). NOAA Earth System Research Laboratory. Retrieved on, 2009-03-14.
48. Xinchang Zhang, Wei Li, Xueyang Chen, Wenyan Cui and Frank Liou, 2018.
49. Evaluation of component repair using direct metal deposition from scanned data *The International Journal of Advanced Manufacturing Technology*, 95: 3335-3348.
50. Yang, R.J., Dewhurst, D.L., Allison, J.E. and Lee, A. Shape optimization of connecting rod pin end using a generic model. *Finite Elements in Analysis and Design*, 1992; 11: 257-264.