

## AUTOMATED VEHICLE NUMBER PLATE RECOGNITION AND AGE VERIFICATION SYSTEM FOR LAW ENFORCEMENT AND POLLUTION CONTROL

\*<sup>1</sup>M. Nirmala and <sup>2</sup>Arunkumar J.

<sup>1</sup>Assistant Professor, <sup>2</sup>MCA Student

<sup>1,2</sup>Department of Computer Applications, Hindusthan College of Engineering and Technology, Coimbatore.

Article Received on 11/05/2023

Article Revised on 01/06/2023

Article Accepted on 21/06/2023

### \*Corresponding Author

**M. Nirmala**

Assistant Professor  
Department of Computer Applications, Hindusthan College of Engineering and Technology, Coimbatore.

### ABSTRACT

This project aims to develop a number plate recognition system using Open CV and Python. The system will detect and recognize the number plate of a vehicle, extract the characters, and use Optical Character Recognition (OCR) to convert the characters into text. Additionally, the system will check the age of the vehicle by comparing its registration date with the current date. If the vehicle is

more than 15 years old, an automatic message will be sent to the owner to inform them of the vehicle's status. This project can be useful for law enforcement agencies, parking management, and other related applications. Vehicle , number plate recognition, openCV, Python, license plate recognition, tesseract OCR, open source, OCR engine, Recognize, text, images, computer vision library , image processing , object detection, segmentation , video frame, alphanumeric characters. Overall, AI can help to automate and optimize the process of identifying and notifying owners of above 15-year-old vehicles that are not used in public places and addressing pollution problems.

**KEYWORDS:** Open CV, Number Plate, OCR, Vehicle, Recognition, Image Processing.

### INTRODUCTION

One of the main objectives related to more than fifteen-year-old vehicles is to reduce their impact on the environment. Older vehicles are typically less fuel-efficient and produce more

emissions than newer vehicles. Encouraging the retirement of older vehicles can help reduce air pollution and greenhouse gas emissions, which can have a positive impact on public health and the environment. Governments and other stakeholders may offer economic incentives to encourage the retirement of older vehicles, such as tax credits, rebates, or financial assistance to purchase newer vehicles. These incentives can help promote the adoption of newer, more efficient vehicles, which can benefit both the individual vehicle owner and the environment. Encouraging the replacement of older vehicles with safer models can improve road safety and fleet modernization. Older vehicles may have outdated safety features, making them more prone to accidents and injuries. This also promotes the adoption of new technologies and reduces maintenance costs associated with older vehicles.

### LITERATURE SURVEY

A novel intelligent traffic monitoring system based on license plate recognition and deep learning algorithm" by Zhang et al. (2021).<sup>[1]</sup> This study proposed a novel intelligent traffic monitoring system based on license plate recognition and deep learning algorithms to detect and record vehicles that exceed the legal limits of emission. The proposed system achieved high accuracy in detecting and recognizing license plates, which led to successful identification of high-polluting vehicles.

Indian Vehicle Number Plate Detection and Recognition using Deep Learning by shrutika et al.<sup>[2]</sup> discussed that the increasing number of vehicles has made it difficult to manually note the number plate text. To reduce manual work, a deep learning-based methodology is proposed to detect the number plate region and recognize its characters. This method uses Region-based Convolutional Neural Networks (RCNN) and Convolutional Neural Networks (CNN) to recognize the number plate region. The system then derives the state name of the vehicle and obtains complete vehicle details from the Vahan-info website. The system stores the number plate text and state name in a database for record-keeping.

Vehicle License Plate Detection OpenCV and Tesseract OCR by Swathi at al.<sup>[3]</sup> uses license plates and image processing to identify vehicles. It can be installed at parking lots, toll booths, or private areas to track vehicles and limit access. The system uses feature extraction and classification for modeling purposes, and has been successful in accurately locating and classifying vehicle numberplates. The proposed method is accurate and precise in detecting plates.

Licence Plate Recognition System Using Open-CV and Tesseract OCR Engine by Rithik at al.<sup>[4]</sup> discusses that advancements in technology have made traffic control and vehicle owner identification a significant problem in the 21st century. This paper proposes a three-stage license plate recognition system using open-CV and tesseract OCR engines. The system includes licence plate detection, character segmentation, and character recognition, using infrared illumination for image capture and text recognition. The primary objective is to design and implement a method for accurate image processing and successful character recognition.

Number Plate Recognition Using Opencv by swetha at al.<sup>[5]</sup> describes that Intelligent license plate detection technology is increasingly important in intelligent traffic management and vehicle video monitoring. This paper studies two methods: Sobel edge detection and morphological gradient detection. Implemented using OpenCV and Python, these methods show high efficiency and good interactivity, providing a reference for future license plate recognition.

Real-Time Automatic Plate Recognition System Based on Optical Character Recognition and Wireless Sensor Networks for ITS by Dalarmelinaet al presents an intelligent vehicle identification system using optical character recognition (OCR) for intelligent transportation systems. It uses the Smart Parking Service (SPANS) framework to identify parking spaces and license plate numbers. The system uses computer vision algorithms to determine availability and conducts real-time evaluations alongside real-time license plate recognition.

An efficient FPGA implementation of optical character recognition for license plate recognition.by Zing et al describes the neuron transfer function, also known as the Tangent Activation Function, is utilised in a feed-forward neural network design for automatic licence plate recognition.

Despite noisy images, 98.2% accuracy was obtained by the network.

Applications include parking access control, toll collection, and traffic monitoring.

As the automotive industry transitions to intelligent transportation, these systems must operate in a variety of conditions, such as road, weather, lighting, and illumination.

Vehicle license plate character segmentation by Pan et al. describes that character segmentation for vehicle license plates (VLPs) is crucial for VLPRS recognition. The least square method (LSM) is suggested for handling horizontal and vertical tilts in VLP images. Chinese dish characters are joined by adding auxiliary lines, and noise regions are eliminated. The Projection Method (PM) is used for segmentation, with quick processing times and effective segmentation. VLP character segmentation is influenced by various methods, including projection, template match, and clustering. Noise interference makes segmentation impossible, but it is fast and simple.

### **Problem Definition**

The problem with vehicle number plate recognition is that it is a tedious and time-consuming task when done manually. It is difficult for humans to accurately and efficiently read and record license plate numbers, especially in cases where there are multiple vehicles involved. This can lead to errors in data entry, which can be costly and potentially dangerous in situations such as toll collection, parking management, and traffic control. Therefore, there is a need for automated systems that can quickly and accurately read license plate numbers, and this is where vehicle number plate recognition technology comes in.

### **Research Methodology**

Vehicle number plate recognition, also known as automatic license plate recognition (ALPR), is a technology that uses optical character recognition (OCR) to automatically read and recognize vehicle license plates. This technology can be used for various applications such as law enforcement, parking enforcement, toll collection, and traffic management. The process of vehicle number plate recognition involves capturing an image of the license plate using a camera, preprocessing the image to enhance the quality of the image, detecting the license plate region, segmenting the characters of the license plate, and then recognizing the characters using OCR. There are several challenges associated with license plate recognition, such as variations in lighting conditions, angle and distance of the camera, and different font styles used in license plates. Machine learning algorithms, such as convolutional neural networks (CNN), can be trained on a large dataset of license plates to improve recognition accuracy. The implementation of vehicle number plate recognition systems requires a combination of hardware and software components, including cameras, image processing algorithms, and OCR software. The system can be deployed on a standalone device or integrated into existing traffic management systems. Vehicle number plate recognition has

the potential to improve traffic management and public safety by enabling automated monitoring and enforcement of traffic laws.

### Modules Description

**Image Acquisition:** The image acquisition module captures an image of the vehicle with a camera. The camera can be placed at a fixed position, such as on a traffic light pole, or mounted on a moving vehicle, such as a police car.

**Preprocessing:** The preprocessing module enhances the quality of the image by removing noise, adjusting brightness and contrast, and improving sharpness. This module is important to ensure that the license plate region is clearly visible and can be extracted accurately.

**License Plate Detection:** The license plate detection module uses image processing techniques to identify the location of the license plate in the image. This module can use techniques such as edge detection, morphology, or machine learning algorithms to detect the plate's position.

**License Plate Segmentation:** The license plate segmentation module extracts the characters of the license plate by segmenting the plate's region into individual characters. This module can use techniques such as connected component analysis, contour detection, or machine learning algorithms to segment the characters.

**Character Recognition:** The character recognition module uses OCR technology to recognize the characters extracted from the license plate. This module can use techniques such as template matching, feature extraction, or machine learning algorithms to recognize the characters accurately. Tesseract OCR can be used with OpenCV and Python for license plate recognition. Tesseract OCR is an open-source OCR engine that can recognize text from images, and OpenCV is a popular computer vision library that provides many functions for image processing and analysis.

To use Tesseract OCR with OpenCV and Python for license plate recognition, the following steps are executed

- Preprocess the license plate image to improve its quality and enhance the license plate area. This could include operations such as noise reduction, contrast adjustment, and edge detection.

- Segment the individual characters from the license plate using techniques such as morphological operations, contour detection, or thresholding.
- Apply Tesseract OCR to recognize the characters on the license plate. You can use the pytesseract library to interface with Tesseract OCR from Python.
- Extract the registration number of the vehicle from the recognized text and use a database to check the age of the vehicle.
- If the vehicle is more than 15 years old, use a messaging API (such as Twilio) to send an automatic message to the owner of the vehicle.

**Postprocessing:** The postprocessing module combines the recognized characters to form the license plate number, validates the license plate number, and performs any necessary error correction. This module can use techniques such as character validation, error correction, or machine learning algorithms to ensure accurate recognition.

**Output:** The output module displays the recognized license plate number on a screen or sends it to a database or other system for further processing. This module can also trigger any necessary actions, such as issuing a ticket or sending an alert to law enforcement.

### Flow Diagram

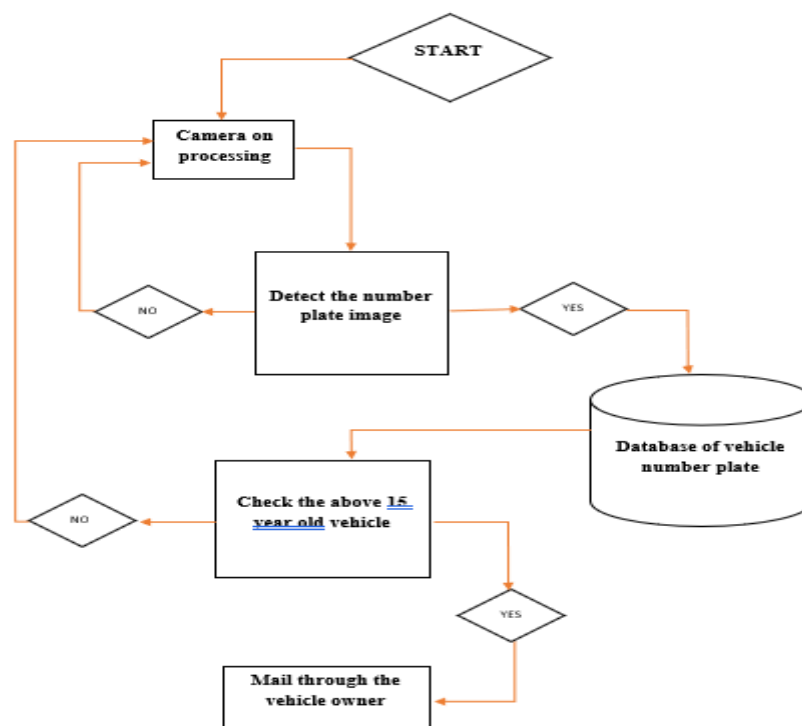

Figure 1: Flow Diagram.

### Block Diagram

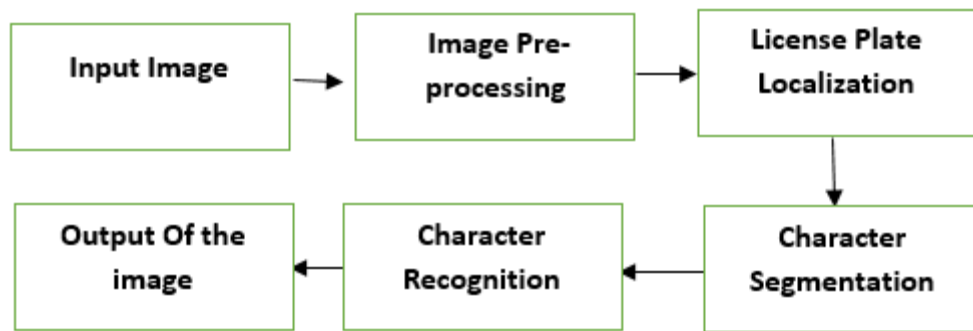

Figure 2: Block Diagram.

- **Input Image:** A digital image of a vehicle that contains a license plate.
- **Image Pre-processing:** The image is pre-processed to enhance the license plate area and remove any noise or unwanted information from the image.
- **License Plate Localization:** The license plate is localized by identifying its position and orientation within the pre-processed image.
- **Character Segmentation:** The individual characters on the license plate are segmented and separated from each other.
- **Character Recognition:** The segmented characters are recognized using OCR (Optical Character Recognition) techniques, such as Tesseract OCR.
- **Output:** The recognized characters are outputted as text or saved to a database for further processing or analysis.

### Implementation

#### Working of Tesseracts OCR Algorithm

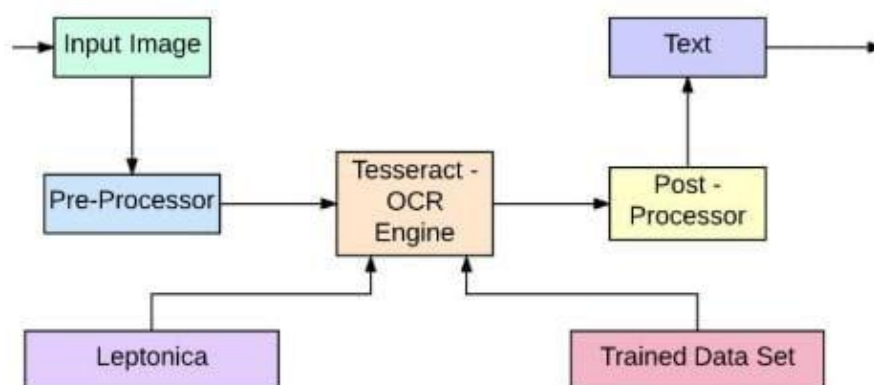

Figure 3: Working of tesseract ocr algorithms.

The `create_car` function creates a registration screen where users can input their vehicle information such as car number, year, email, and name. Upon clicking the "Register" button, the data is stored in the database. The program function initiates the video capture from the camera. It applies number plate detection and recognition algorithms to identify the number plate in each frame. Once a number plate is detected, it is passed to the OCR engine (Tesseract) to extract the characters. If the recognized number plate matches predefined conditions, such as being over 15 years old, a notification email is sent to the vehicle owner using the provided email address. The code establishes a connection to the MySQL database and creates a table to store the vehicle information.

The project script is tested on various pictures and was successful with certain pictures that were available under certain dimension frames. The image was successfully enhancing the image quality and was converting the image to binary and morphed image. The project extracts the number plate from the car image and displays it separately. The project successfully prints half of the License plate number after performing Optical Character Recognition using pytesseract. The accuracy issues are there in the Tesseract engine and can be enhanced after enhancing the configuration of the engine.

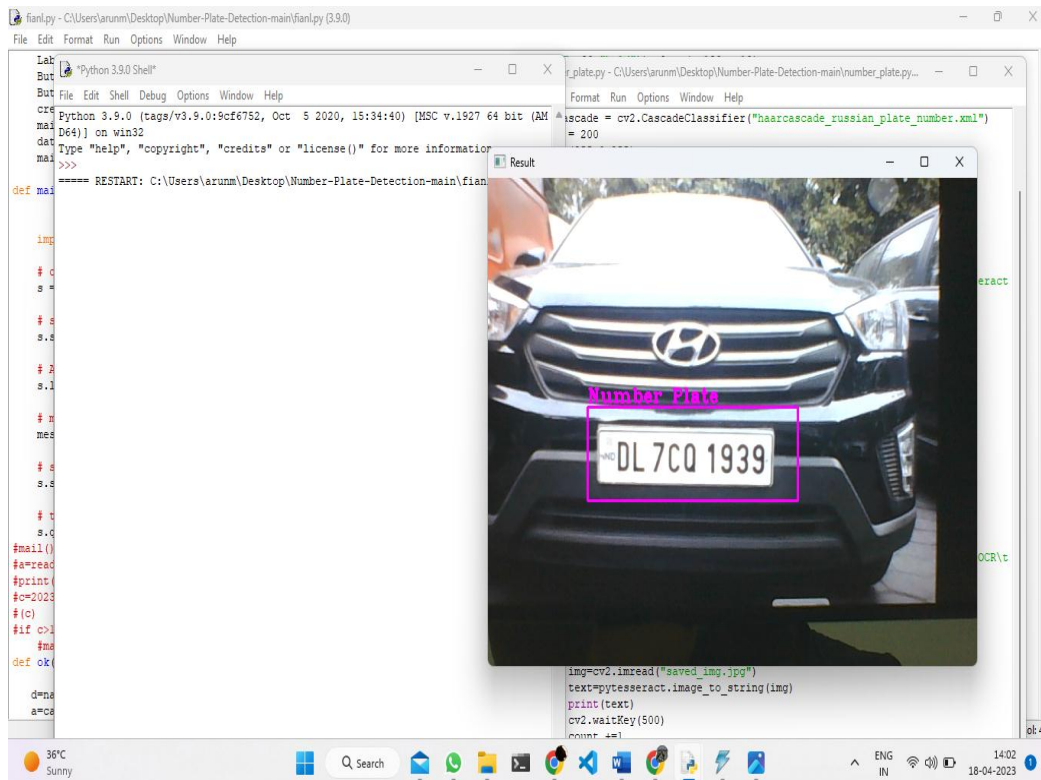
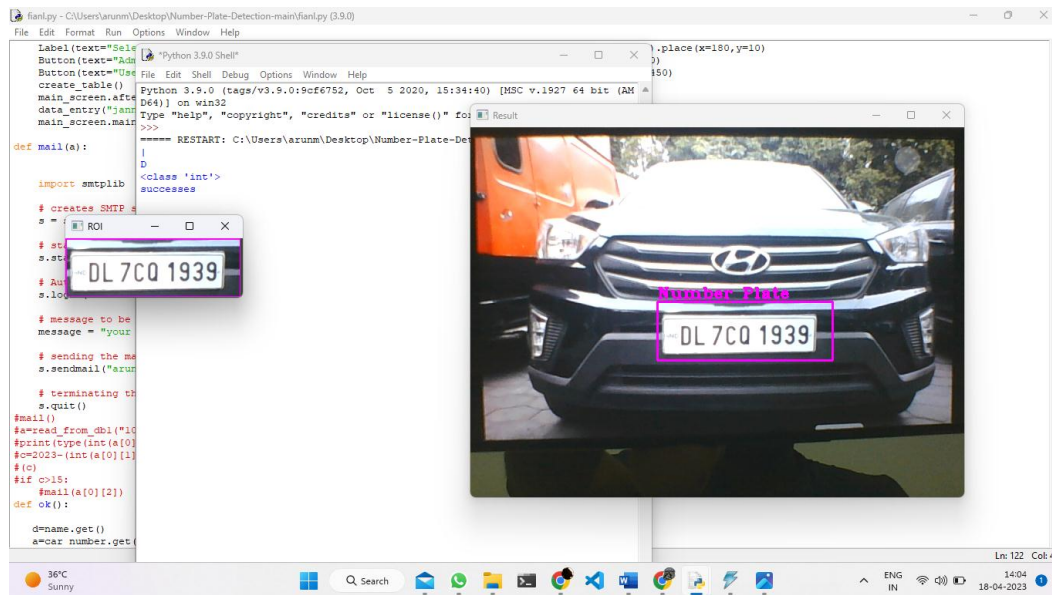
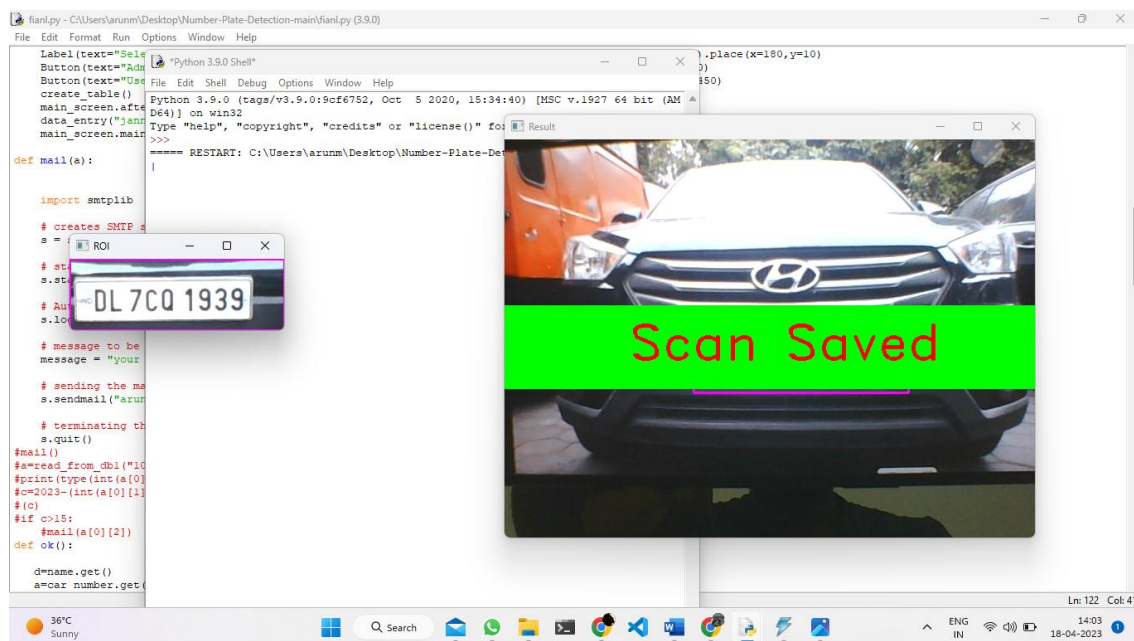

Figure 4: Input Image.





**Figure 5: Plate is extracted in a separate window.**



**Figure 6: Scanned Image Saved.**

## CONCLUSION

The paper demonstrates a basic implementation of a vehicle number plate recognition system with age verification. It utilizes computer vision techniques for number plate detection, OCR for character recognition, and a MySQL database for storing and retrieving vehicle information. The code successfully captures video frames, detects number plates, and extracts characters using Tesseract OCR. It then checks the recognized number plate against predefined conditions (such as age) and sends a notification email if necessary.

### Future Enhancements

Future enhancements for addressing the challenges posed by vehicles over 15 years old can include

1. Developing more advanced emissions testing technologies to accurately measure emissions and identify vehicles that are not compliant with environmental regulations.
2. Integrating AI-based systems with other technologies, such as facial recognition and license plate recognition, to improve the accuracy and effectiveness of law enforcement and parking management.
3. Implementing incentives and subsidies for owners to retire or upgrade their old vehicles, which can help to reduce emissions and improve safety.
4. Investing in research and development of new vehicle technologies, such as electric vehicles and autonomous vehicles, which can help to reduce emissions and improve safety.

By taking a comprehensive approach to addressing the challenges posed by vehicles over 15 years old, it is possible to improve the overall safety, environmental impact, and efficiency of the transportation system.

### REFERENCES

1. H. Zhu, Y. Wang, and C. Zhang, "License plate recognition based on OpenCV and Tesseract OCR," in Proceedings of the International Conference on Artificial Intelligence and Computer Engineering (ICAICE), Harbin, China, 2020; 17-19, 2020; 363-366.
2. Lalitha Madanbhavi ,Geeta R. Bharamagoudar ,Nikita Parakh , Nikhil Pujari Praveen Kakhandaki, Meena S.M, Indian Vehicle Number Plate Detection and Recognition using Deep Learning, Journal of Positive School Psychology, 2022; 6(5): 5400–5405.
3. P.Swathi, N.Sree Haritha, G.Venkata Sai Krishna, A.Veena Jasmine, V.Vamsi Krishna, Y.Sai Dinesh Reddy, Vehicle License Plate Detection OpenCV and Tesseract OCR, Dogo Rangsang Research Journal, January 2023; 13(1): 2.
4. Rithik B, Raghav G, Harshith M, Rahul Patwadi, Aravind H S, Licence Plate Recognition System Using Open-CV and Tesseract OCR Engine, International Journal of Engineering Research in Computer Science and Engineering (IJERCSE), 2022; 9(9).
5. S.Swetha,Dr K Merrilance NUMBER PLATE RECOGNITION USING OPENCV, International Journal of Creative Research Thoughts, 2022; 10(12).

6. Dalarmelina, N.d.V.; Teixeira, M.A.; Meneguette, R.I. A Real-Time Automatic Plate Recognition System Based on Optical Character Recognition and Wireless Sensor Networks for ITS. *Sensors*, 2020; 20: 55. <https://doi.org/10.3390/s20010055>.
7. Jing, Y.; Youssefi, B.; Mirhassani, M.; Muscedere, B. An efficient FPGA implementation of optical character recognition for license plate recognition. In *Proceedings of the IEEE 30th Canadian Conference on Electrical and Computer Engineering*, Windsor, ON, Canada, 2017; 30.
8. Pan, M.; Yan, J.; Xiao, Z. Vehicle license plate character segmentation. *International J. Autom. Comput.*, 2008; 5: 425–432.
9. Jameson, H. S. Abdullah, S. Norul, A. N. Ghazali, N. Nur, and N. A.Zamani, "Multiple Frames Combination Versus Single Frame Super Resolution Methods for CCTV Forensic Interpretation," *Journal of Information Assurance & Security*, 2013; 8.
10. N. Vishwanath, S. Somasundaram, M.R. Rupesh Ravi, N. Krishnan Nallaperumal," Connected Component Analysis for Indian License Plate Infra-Red and Color Image Character Segmentation", *IEEE International Conference on Computational Intelligence and Computing Research*, 2012.
11. Ragini Bhat, Bijender Mehandia," Recognition of vehicle number plate using matlab", *International journal of innovative research in electrical, electronics, instrumentation and control engineering*, 2014; 2(8).
12. Cheng-Hung Lin, Yong-Sin Lin, and Wei-Chen Liu, An efficient license plate recognition system using convolution neural networks. *2018 IEEE International Conference on Applied System Invention*. [6] R. Girshick, F. Iandola, T. Darrell, J. Malik, Deformable Part Models are Convolutional Neural Networks. *arXiv preprint arXiv:1409.5403*, 2014. in *CVPR*, 2015.
13. S. Du, M. Ibrahim, M. Shehata, and W. Badawy. Automatic license plate recognition (alpr): A state-of-the-art review. *Circuits and Systems for Video Technology, IEEE Trans. on*, 2013; 23(2): 311- 325.