

### HANDLING AND INSTALLATION OF INTAKE WHEEL DRAFT TUBE GATE BY REPLACING EXISTING INTAKE GATE USING DOGGING BEAM AND HYDRAULIC CYLINDER DEVICE

Mehul Panchal\*

P.E. Kiewit Engineering Group Inc. 8900 Renner Blvd. Lenexa, KS 66219.

Article Received on 22/09/2024

Article Revised on 12/10/2024

Article Accepted on 02/11/2024



\*Corresponding Author

Mehul Panchal

P.E. Kiewit Engineering  
Group Inc. 8900 Renner  
Blvd. Lenexa, KS 66219.

#### ABSTRACT

This article discusses handling and installing of new intake wheel draft tube gate in existing gate slot using existing hydraulic cylinder removed from existing gate and dogging beam device. Hydraulic and electrical lines removed from an existing hydraulic cylinder of existing gate which was deteriorated and not in operable condition. Their reconnection of hydraulic and electrical lines along with the existing hydraulic cylinder are assembled to new intake wheel gate and installed the assembled gate in the gate slot. A step-by-step procedure

being discuss in this article for handling and installation of new hydraulic gate upon removal of existing gate and its cylinder.

**KEYWORDS:** Hydraulic cylinder, dogging beam, draft tube wheel gate, mobile crane, crane hook, tie-downs, adjustable steel jack post.

#### INTRODUCTION

In the planning and rehabilitation of hydro project, selection of appropriate procedure for replacement of existing intake wheel gate with new fabricated one is challenging task. If the replacement procedure for any intake wheel gate whether for intakes, spillways or outlets, is not appropriate, the safety of project could be jeopardized. It is imperative to layout of gate hydraulic cylinder with hydraulic and electrical lines and dogging beam device for gate replacement is finalized only after all factors such as cost and safety are addressed.

### ITEMS OF CONCERN

The following items affect the handling and installation of vertical lift wheel gate using dogging beams and existing gate hydraulic cylinder devices in existing gate slot with the help of crane lifting point. (This type of gate is being considered as an example because this is most common type used for hydro project)

- A. Storage of existing gate sections after removal from its gate slot and install new gate section following its storage position.
- B. Installation of hydraulic cylinder along with hydraulic and electric lines.
- C. Suitable dogging beam arrangement to hold the gate in suspended vertical position within gate slot and designed as not to damage bottom seal of gate while in dogged position, it has to be properly secured with chain or turnbuckle anchored into concrete and support strut with gate body and gate slot itself.
- D. Logistic limit and transportation challenges of fabricated gate section in trailer to get to the site from its storage position and lifting the gate using crane without risk of falling it.
- E. Logistic limit and transportation challenges of fabricated gate section in trailer to get to the site from its storage position and lifting the gate using crane without risk of falling it.
- F. Plumbness of gate during replacement of new intake wheel gate.

### SUGGESTED PROCEDURE FOR HANDLING AND INSTALLATION OF NEW DRAFT TUBE GATE

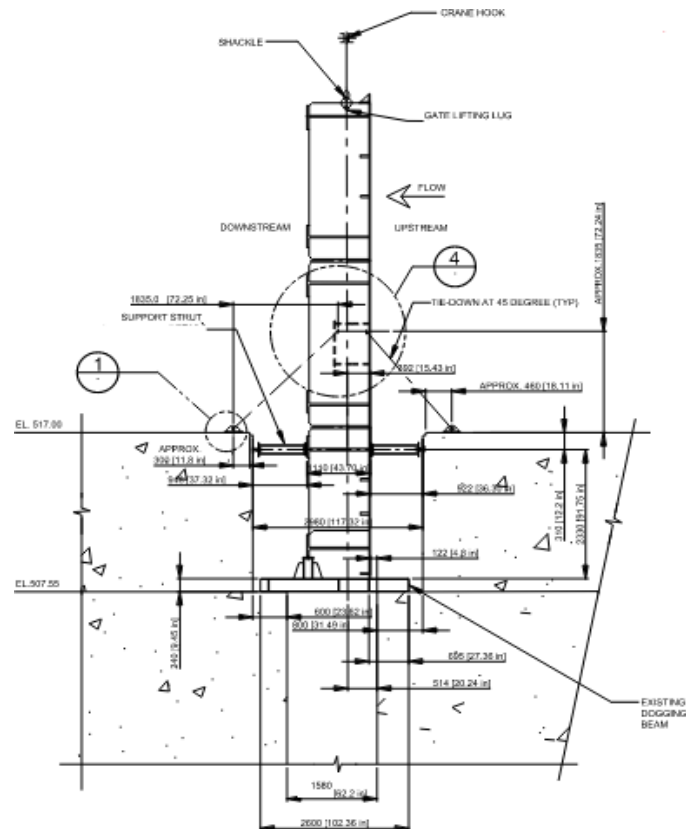
It is anticipated that all three sections of new draft tube gate and related accessories will be delivered to the project site by fabrication contractor and stored by the Owner in a horizontal position supported on cribbing/wooden blocks at a storage area to be determined by the Owner until they are ready to be assembled and installed in the gate slot.

When any of the three existing gates needs to be removed from its slot for an extended period for maintenance / rehabilitation, the new gate may be assembled and installed in place of the removed existing gate to minimize the concerned generating unit's outage duration. With a suitable mobile crane and lifting beam (existing, 65-ton capacity), remove the selected existing gate from its slot and disassemble the gate into three sections and the hydraulic cylinder on the powerhouse roof deck at EL. 517. Using a suitable flatbed trailer truck, move and store the disassembled gate sections away from the deck at an area designated by the Owner. Set the cylinder and its support frame aside properly supported on the deck for later re-installation.

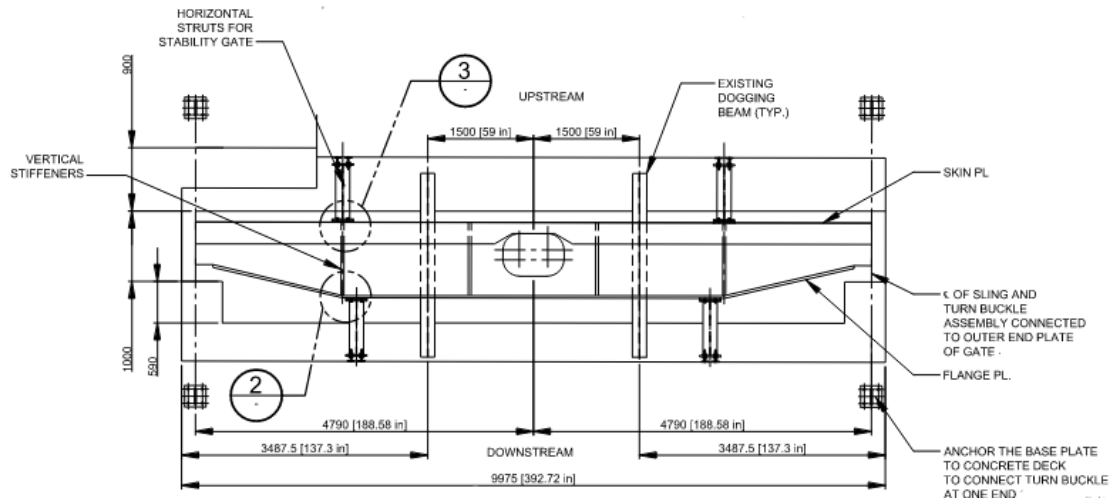
The new draft tube gate sections can then be moved from their storage area to the deck (properly cribbed in horizontal position) in preparation for final assembly and installation into the slot. For handling and rotation of individual gate sections from a horizontal to a vertical position, two suitable mobile cranes can be used with slings and shackles (each with minimum 30-ton rating) installed on the gate lifting/handling lugs (two at top and two at bottom of each gate section); the lifting beam should be connected to the top two shackles.

The required capacity of the mobile crane to be used for handling the fully assembled gate and cylinder shall be at least 65-ton at its extended boom.

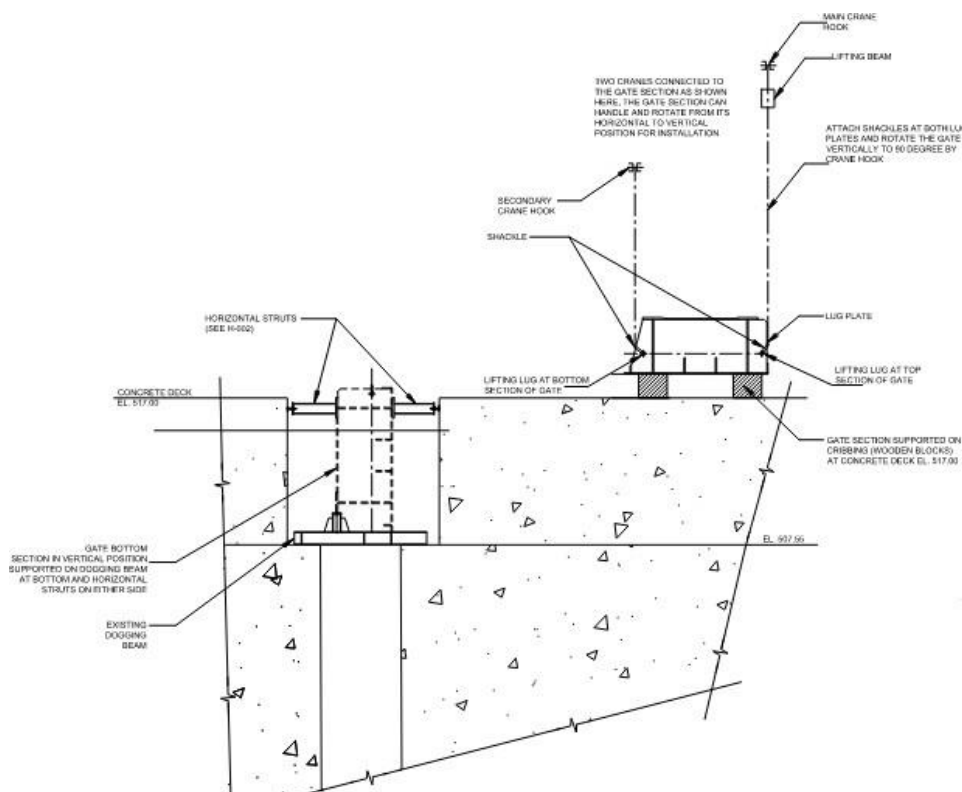
**STEP 1:** Place and level the two dogging beams (existing) on platform at EL 507.55 as shown on suggested dogging arrangement Fig. 1a and Fig. 1b. Pick the lower gate section using the mobile cranes and rotate it vertically from its horizontal position as shown in Fig. 1c. With one crane and the lifting beam connected to the top lifting lugs holding the gate section vertically off the ground, detach the bottom two shackles and slings from the second mobile crane.



**Fig. 1a: Dogging Arrangement Side View.**

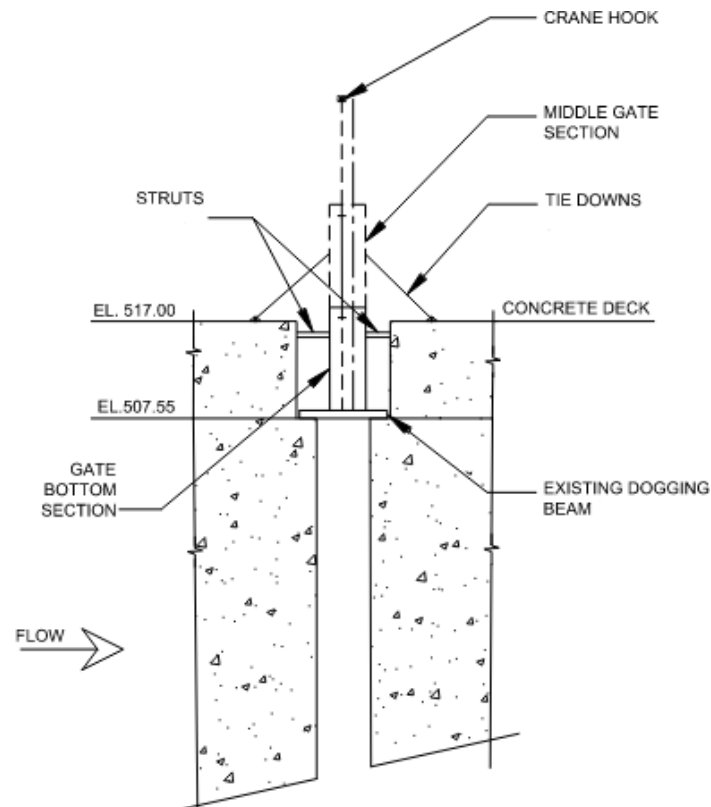


**Fig. 1b: Suggested Dogging Arrangement Plan.**



**Fig. 1c: Suggested Handling Arrangement for Gate Section.**

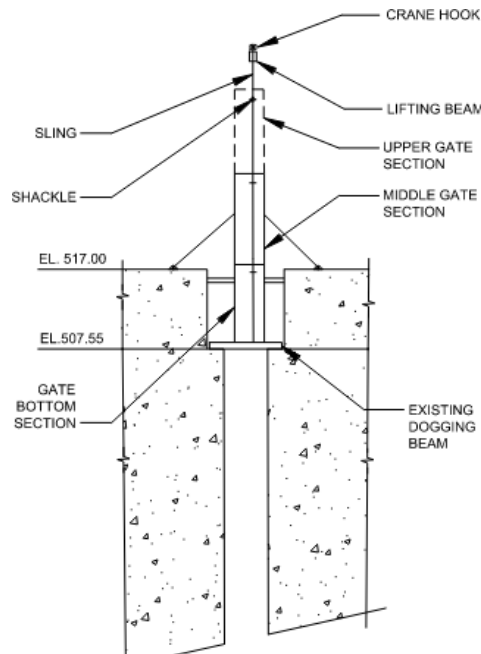
Lower the gate section onto the two dogging beams. With the crane still holding the gate section upright, install support struts on both upstream and downstream sides of gate section for stability as shown in Fig. 1a and Fig. 1b.



**Fig. 1d: Bottom Section of Gate in Dogged Position.**

Unhook the crane from lower section. Repeat the steps to place the middle gate section on top of the lower gate section. With one crane holding the middle gate section upright, install the link plates/pins to connect the two sections together. Install tie-downs as shown in Dogging Arrangement section and plan per Fig. 1a to further stabilize the gate sections. Detach the shackles from the top of middle gate section.

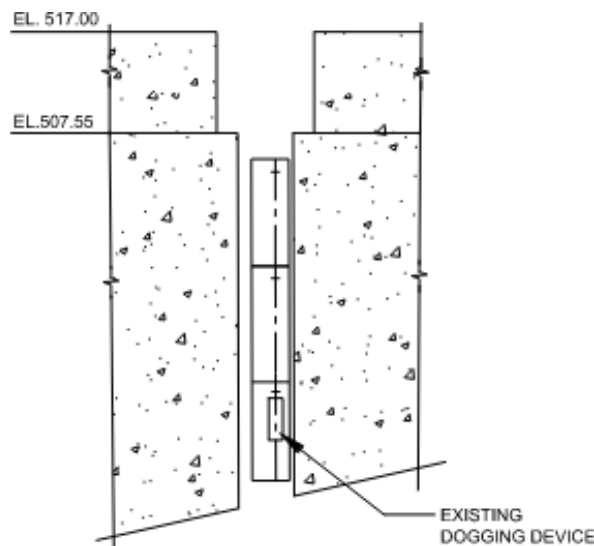
**STEP 2:** Similarly, repeat the steps to place the upper gate section on top of the middle gate section and connect the link plates/pins.



**Fig. 2: Middle Section of Gate in Dogged Position.**

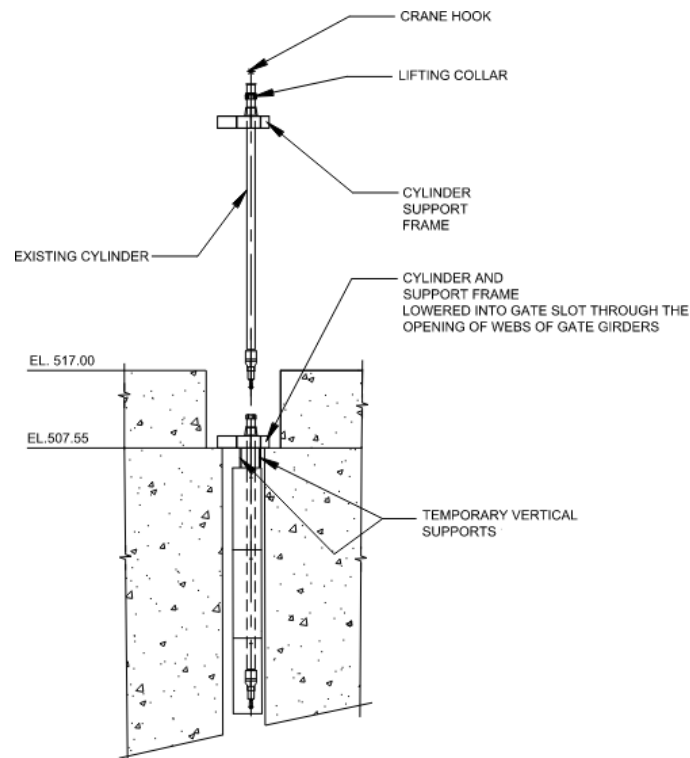
**Step 3:** once all three sections of gate are linked together, with the crane still holding the gate (via lifting lugs on the upper gate section), remove the supporting struts and tie-downs. Lift the assembled gate slightly using the mobile crane and remove the dogging beams from bottom of gate. Engage the dogging devices (existing) installed on each lateral side in the gate slot (at approx. EL 480 shown in Fig. 3a) by actuating the corresponding lever mounted on platform at EL 507.55. Lower the gate down and dog the gate in the slot just above the draft tube as shown in step.

### 3. Unhook the crane from the gate

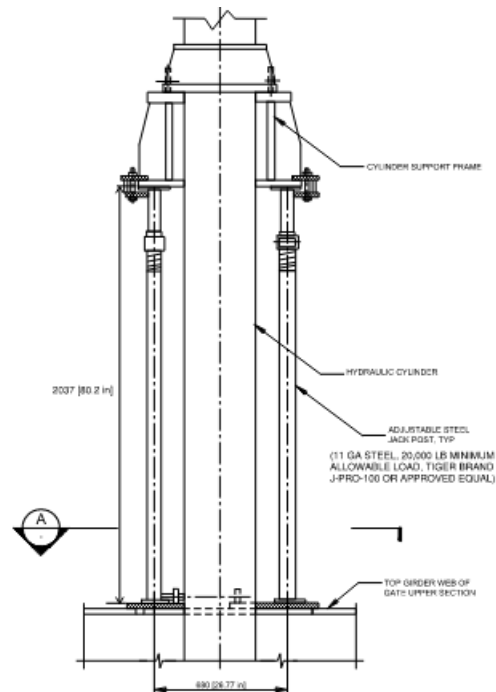


**Fig. 3: Lower the New Intake wheel gate and Dogged in Gate Slot.**

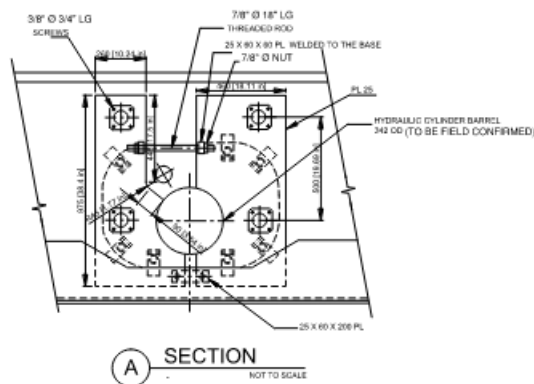
**STEP 4:** Install lifting collar (existing) near the top of the existing cylinder (connected to its support frame), which was previously disassembled from the existing gate. Connect the lifting collar to a mobile crane's hook with slings. Attach another set of slings near the bottom (piston rod end side) of the cylinder and connect to a second mobile crane. With both cranes, rotate the cylinder from a horizontal position to a vertical position. With the first mobile crane holding the cylinder upright off the ground, unhook the second mobile crane. Lower the cylinder along with its support frame into the gate slot through the openings in horizontal girder webs of the dogged gate until the bottom of cylinder support frame rests on the platform at EL507.55.



**Fig. 4a: Install Hydraulic Cylinder into Existing Gate to Remove Existing Gate.**



**FIG. 4b**  
SUGGESTED ARRANGEMENT OF  
TEMPORARY VERTICAL SUPPORTS FOR HYDRAULIC CYLINDER  
NOT TO SCALE

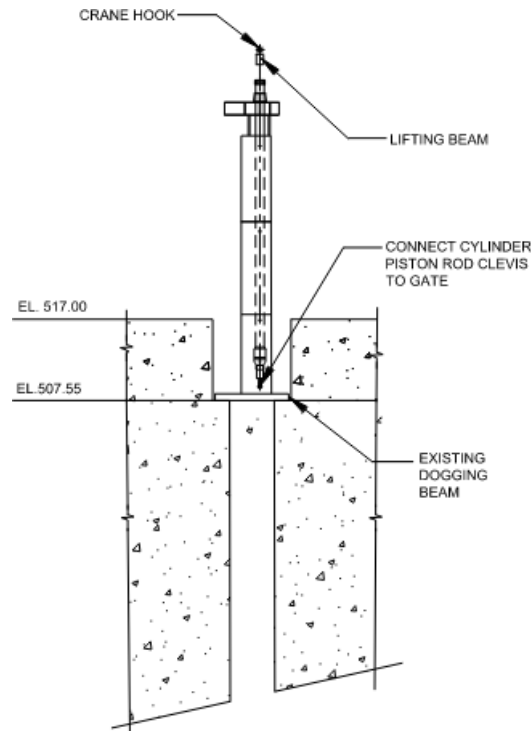


**Fig. 4b: Install Temporary Vertical Support at Top of the Gate.**

Install temporary vertical supports bolted between top of gate and bottom of cylinder support frame for stability as shown in Fig. 4b. Unhook the crane and remove the lifting collar from the cylinder.

**STEP 5:** Connect the crane hook to the lifting lugs on the gate upper section using lifting beam, shackles, and slings. Lift the gate and cylinder assembly high enough to place the two dogging beams on platform at EL 507.55.

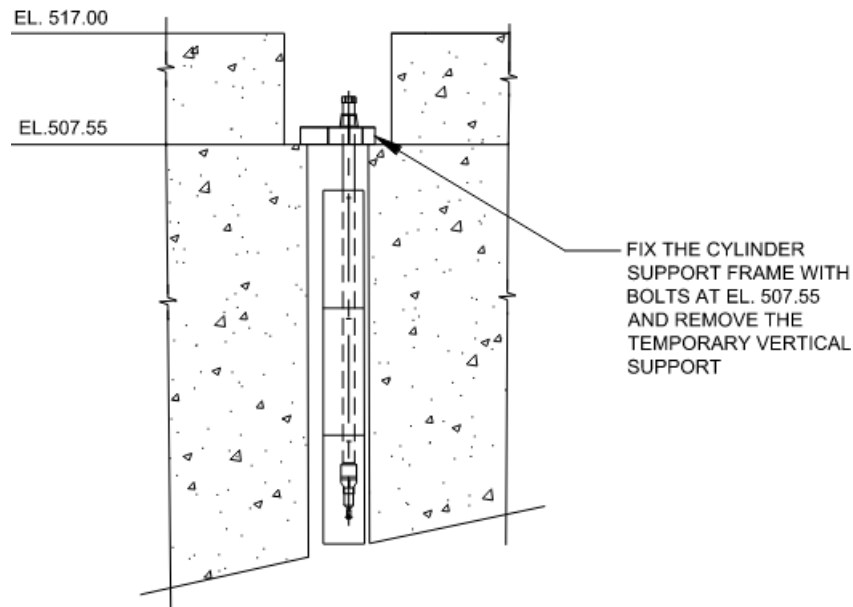




**Fig. 5: Install Cylinder to New Gate Supported by Dogging Beam.**

Lower and rest the gate on the dogging beams. With the crane holding the gate in this position, person can access the bottom girder of the lower gate section from the platform at EL 507.55 to connect the cylinder piston rod clevis to the gate. Install cylinder protective cage (furnished by the Owner) on to the gate. Position the levers to disengage the dogging devices in the slot.

**STEP 6:** Lift the gate slightly using the crane again and remove the dogging beams. Lower the gate into the slot until the bottom of support frame rests on the platform at EL 507.55. Install the anchor bolts for the cylinder support frame, reconnect the hydraulic piping and electrical conduits, and remove the temporary vertical supports between the gate and the cylinder support frame (refer Fig. 4b). Unhook the crane. The gate is now ready for testing and operation with the hydraulic cylinder.



**Fig. 6: Lower the Gate into Existing Slot.**

Procedure for removal of gate and cylinder will be similar to the steps as described above except in reverse.

The steps to be used for removal, disassembly, re-assembly, and re-installation of the existing gates are not included herein but expected to be similar, except that the new gate includes a different arrangement of connections between gate sections as well as designated attachment points for temporary struts, tie-downs, and vertical supports.

## CONCLUSION

It is concluded that the handling and installation method per above mentioned step by step procedure for intake wheel gate can be varied depending upon what is present in terms of existing condition of gate (s) is/are to be replaced using either wire rope with hoisting platform or hydraulic cylindrical device and turnbuckle and dogging device with support beam to dog the gate. At the end, it is up to hydro project owner to decide which procedure is deemed appropriate upon hydromechanical/structural engineer suggested procedure similar to what was described in this paper.

Disclaimer: The contents of this paper reflect the views of author who is responsible for the facts and accuracy of the data presented herein. These contents do not constitute a standard, specification, or regulation.

**REFERENCES**

- A. Design of Hydraulic Gates by Paulo Erbisti (2<sup>nd</sup> Edition).
- B. Ohio River Hydropower Project Drawings for Handling and Installation Plan and Procedure.
- C. Personal Notes.